



SITE
FRENDEL KITCHENS

Sales Selection Sheet
Wallaceton

45 of 52

PURCHASER: Swetha Khaidalagudam

TEL:

LOT / UNIT 3192B-10	PHASE 3	MODEL 20-1790 A The Dunmore	
------------------------	------------	--------------------------------	--

It is herein understood and agreed between the undersigned parties hereto that the following changes shall be made to the above mentioned Agreement of Purchase and Sale in accordance with the agreement and except for such changes noted below, all other terms and conditions in the Agreement of Purchase and Sale shall remain as stated herein: It is further understood that and agreed that all changes and additions shall be installed as per builder's specifications, location and available selections. The Purchaser hereby agrees to purchase the following extras:

APPLIANCES

1	KITCHEN - PLEASE SEE SPECS FOR NEW SAMSUNG RF32CG5900SR 30 CU FT FRIDGE AND BUILT-IN SAMSUNG MICROWAVE MS19M8000A/TRIM KIT MA-TK8020TS/AA AND WALL OVEN NV51K777OSS CONFIRMED BY FRENDEL KITCHENS THIS CAN STILL BE ACCOMODATED SEE NEW SPECS	Qty: 1.0000	
129,372	Note: DELETE ORIGINAL SPECS FOR SAMSUNG 27 CU FT FRIDGE RF27T5501SR AND 30" FRIGIDAIRE B/I MICROWAVE GMBD3068AF AND WALL OVEN GCWS3067AF		

Sub Total
HST
Total

- This Sales Selection Sheet when properly executed forms part of our Agreement of Purchase and Sale.
- All extras and upgrades listed above are subject to Construction Progress and Architectural and Municipal requirements.
- In the event the Vendor is unable to incorporate the work approved above in the construction of the house for any reason whatsoever, the Vendor will not be liable to the Purchaser in any way. The monies paid for any changes or optional extras not proceeded with shall be returned to the Purchaser, without interest. The cost of options or extras is non-refundable in all other circumstances. If for any reason whatsoever the Agreement of Purchase and Sale is not completed, the total cost of work approved above will be retained by the Vendor.
- The Vendor reserves the right to substitute above materials and equipment with that of equal or better quality.
- Purchaser acknowledges that items may not be exactly as shown. Variations from the Vendor's samples may occur in finished materials due to normal production processes. Vendor is not responsible for shade difference which may occur from different dye lots or wood grains. Variations from the Vendor's samples will occur with natural materials such as wood, marble, granite, hardwood and brick.
- The Vendor reserves the right to select Grout & Thresholds that best suits the Tile selected.
- Selections will not be processed unless signed by Heathwood Homes Head Office.
- The selections made on this schedule are final and cannot be changed once submitted.
- The Purchaser has checked and acknowledges the accuracy of this schedule.

Payment Summary	
<u>Paid By</u>	<u>Amount</u>
<u>Total Payment:</u>	

PURCHASER: Signature on file 12-Oct-23 TINA LEFOR 12-Oct-23
 Swetha Khaidalagudam DATE Decor Consultant DATE
 by email
 -10- 12 2023
 Date Approved Heathwood Homes (Huron) Limited

TAX#:1

PREPARED BY: Marilyn Rosen

PE 1,578-1

SInvoice.rpt 28may19

RF32CG5900SR

SAMSUNG

Large Capacity 3-Door French Door 30 cu. ft. Full Depth Refrigerator with Family Hub™ and 4 types of ice

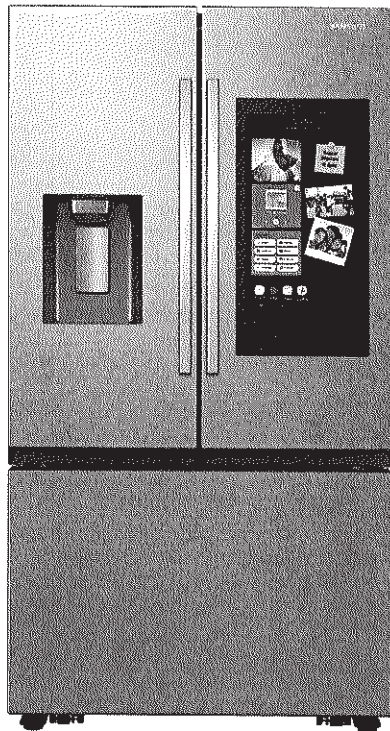

Signature Features

Family Hub™

Samsung's Family Hub™ refrigerator helps you connect to what's most important: your family and home. Family Hub™ lets you see inside your refrigerator, manage your family's calendars, stream music, see who's at the front door and much more, all right from your fridge.

Large 30 cu. ft. Capacity

Store more groceries with more room to stay organized. Large 30 cu. ft. capacity fits big and bulky items and provides easy access to everything you need.

Four Ice Types

Enjoy your favorite beverage with your choice of ice. Choose cubed ice or Ice Bites™ from the Dual Ice Maker in the freezer drawer, or opt for curved or crushed ice from the external dispenser.

Available Color

 Fingerprint Resistant
Stainless Steel

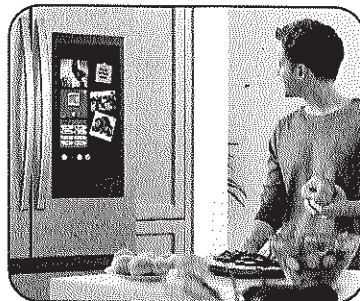

Family Hub™

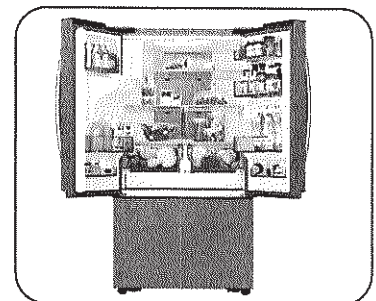

Large 30 cu. ft. Capacity

Design

- Family Hub™
- Premium External Filtered Water and Ice Dispenser
- Large Capacity of 30 cu. ft.
- High-Efficiency LED Lighting
- Gallon Door Bin
- Fingerprint Resistant Finish

Technology

- Wi-Fi Enabled
- Power Cool & Power Freeze
- Door Alarm
- Water Filter Indicator

Performance

- Four Ice Types: Crushed, Curved, Cubed and Ice Bites™
- SmartThings Energy*
- Metal Cooling

*Available on Android and iOS devices. A Wi-Fi connection and a Samsung account are required.



Rating



ENERGY STAR® rated:
781 kWh/yr

RF32CG5900SR

SAMSUNG

Large Capacity 3-Door French Door 30 cu. ft. Full Depth Refrigerator with Family Hub™ and 4 types of ice

Installation Specifications

1. Measure the height, width and depth of the opening, making sure to include baseboards, molding tile, countertop overhang, etc. Check to be sure there is enough room to open the door (consider walls, islands or other obstacles when measuring).
2. Refer to illustration below to determine dimensions.
3. Allow 2.5" of clearance on hinge side of refrigerator when installing next to a wall where handle may make contact.
4. Allow 1" minimum clearance at rear for proper air circulation and water/electrical connections. Allow a 3/8" minimum clearance at sides and top for ease of installation.
5. Ensure each door and entryway in the home is wide enough for the refrigerator to be moved through easily.

For optimal usage and ability to open refrigerator doors completely, do not install next to a wall.

Please note: The following dimensions and cutout information is for planning purposes only. For complete installation details, consult manual packed with product or download manual online at samsung.com.

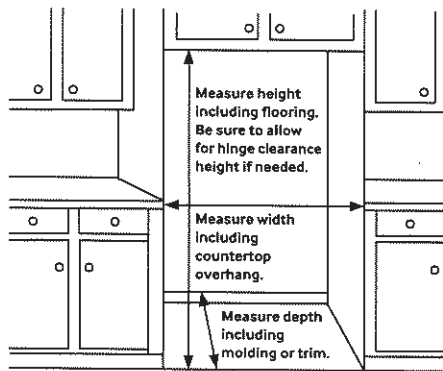

Total Capacity: 30 cu. ft.

Refrigerator: 20.8 cu. ft.

- External Filtered Water and Ice Dispenser
- 4 Tempered Glass Spill-Proof Shelves
- Full-Width Drawer
- 2 Clear Drawers
- 7 Door Bins
 - Right: 1 Gallon Bin, 3 Regular Bins
 - Left: 3 Regular Bins
- High-Efficiency LED Lighting

Freezer: 9.2 cu. ft.

- Dual Ice Maker in Freezer (Cubed Ice or Ice Bites™)
 - 2 Removable Ice Buckets and 1 Scoop
- 2 Large Opaque Bins with 1 Divider
- High-Efficiency LED Lighting

Accessories

Water Filter: HAF-QIN

Warranty

One (1) Year Parts and Labor on Refrigerator
 Five (5) Years Parts and Labor on Sealed Refrigeration System Only*
 Ten (10) Years Parts and Five (5) Years Labor on Digital Inverter Compressor

*Compressor, evaporator, condenser, drier and connecting tubing.

Product Dimensions & Weight

Dimensions (WxHxD with hinges, handles and doors):
 35³/₄" x 70" x 36¹/₄"

Dimensions (WxHxD without hinges and door):
 35³/₄" x 68⁷/₈" x 29¹/₂"

Dimensions (WxHxD with hinge and door, no handle):
 35³/₄" x 70" x 34⁵/₈"

Weight: 323 lbs

Shipping Dimensions & Weight (WxHxD)

Dimensions: 37³/₄" x 75⁷/₁₆" x 36"

Weight: 333 lbs

Color

Model #

UPC Code

Fingerprint Resistant
 Stainless Steel

RF32CG5900SR 887276775562

Dimensions

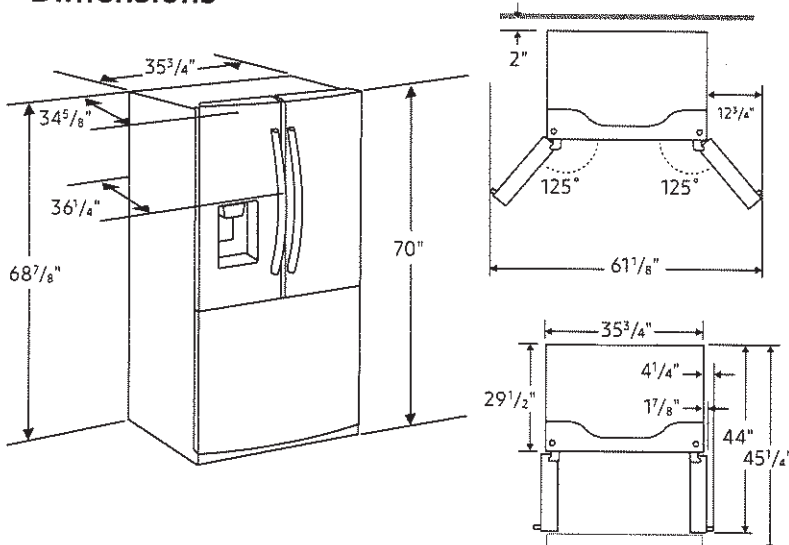

MS19M8000A

SAMSUNG

Samsung Countertop Microwave

1.9 cu. ft. Capacity

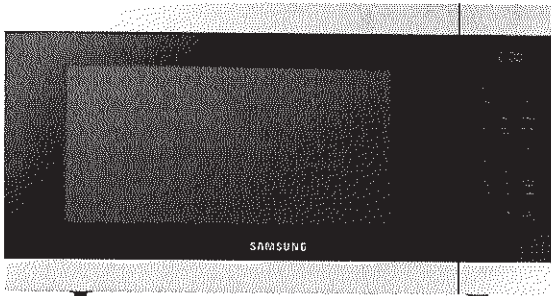

Signature Features

1.9 cu. ft. Capacity

- Accommodates a variety of dishes so you can prep large meals quickly.

Sensor Cook

- Automatically adjusts cooking time for optimal results.

Ceramic Enamel Interior

- Makes removing grease or oil effortless and protects against scratches from daily use.

Available Colors



Stainless Steel (shown)



Black Stainless Steel

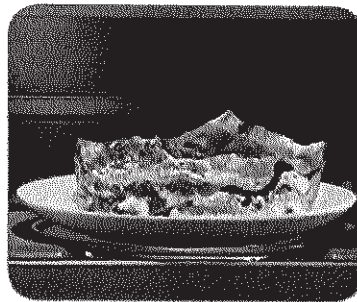

Sensor Cook

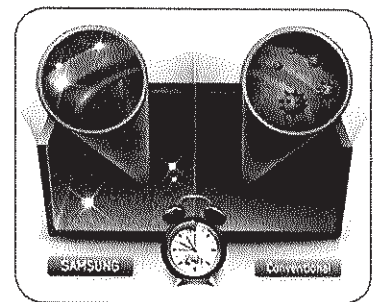

Ceramic Enamel Interior

Features

- Eco Mode
- Cooking Presets
- 950W of Cooking Power
- 10 Power Levels
- Auto Defrost
- LED Display
- 30" Trim Kit Options Available (see next page for details.)

Convenience

- Kitchen Timer
- Clock (12hr/24hr) with Daylight Saving Time Adjustment
- Child Safety Lock
- Reminder End Signal

MS19M8000A

SAMSUNG

Samsung Countertop Microwave

1.9 cu. ft. Capacity

Dimensions

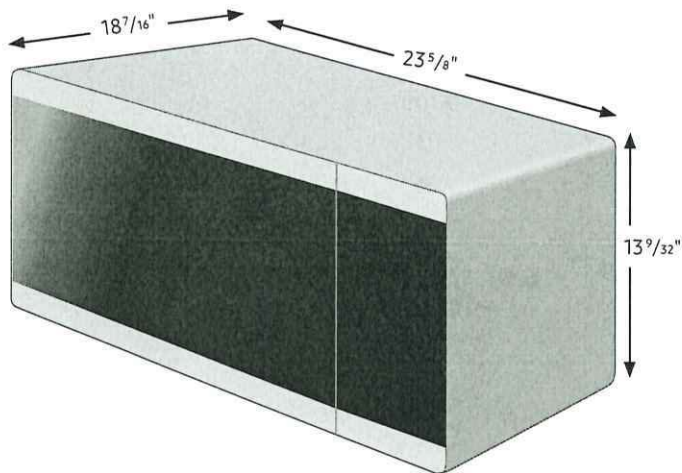

Specifications

- Oven Cavity: 1.9 cu. ft.
- Power Output: 950W
- Power Consumption: 1600W/13.3 A
- Power Source: 120V / 60 Hz
- Control Method: Electronic Touch
- Display: LED (Ice Blue)
- Cooking Control: 10 Power Levels Including Defrost
- Cooking Timer: Digital, up to 99 Minutes, 99 Seconds
- Microwave Distribution System: Turntable

Warranty

One (1) Year Parts and Labor
 Ten (10) Years on Magnetron Microwave Technology

Product Dimensions & Weight (WxHxD)

Outside Dimensions: 23^{5/8}" x 13^{9/32}" x 18^{7/16}"

Interior Cavity Dimensions: 17^{3/8}" x 10^{5/8}" x 17^{13/16}"

Weight: 43.03 lbs.

Shipping Dimensions & Weight (WxHxD)

Dimensions: 26^{1/4}" x 16^{13/32}" x 20^{1/4}"

Weight: 47.97 lbs.

Microwave Color	Model #	UPC Code
Stainless Steel	MS19M8000AS	887276212050
Black Stainless Steel	MS19M8000AG	887276212043

Countertop Microwave and Trim Kit for Built-in Applications

For installation with Wall Ovens, respective codes must be paired together:

Color:	Product:	Model #:	UPC Code:
Stainless Steel	Microwave	MS19M8000AS	887276212050
Stainless Steel	Trim Kit	MA-TK8020TS	887276224466
Black Stainless Steel	Microwave	MS19M8020TG	887276212067
Black Stainless Steel	Trim Kit	MA-TK8020TG	887276224459

EARLY HOLIDAY SAVINGS Save throughout the site [SHOP NOW](#)

Home / Appliances / Appliance Accessories / Microwave/Micro Hood Accessories / Samsung MA-TK8020TS/AA

Samsung 30" Stainless Steel Microwave Trim Kit - MA-TK8020TS/AA

★★★★★ 15 Reviews | 7 Questions - 7 Answers

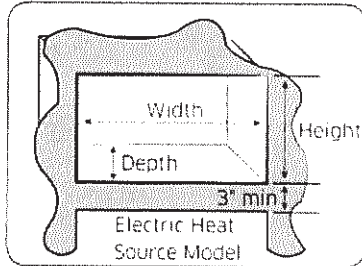

CUTOUT DIMENSIONS

Height	16 3/4" ± 1/16"
Width	25 1/2" ± 1/16"
Depth	21 1/2" ± 1/16"

TRIM DIMENSIONS

Height	20 1/16" ± 1/64"
Width	29 3/4" ± 1/64"
Depth	1 1/4" ± 1/64"

TRIM WEIGHT

Net Weight	13.23 lb
------------	----------

♡ 17

⚠ WARNING

To avoid risk of electrical shock, personal injury, or death:

- Before drilling into the wall, note where electrical outlets are and where electrical wire might be concealed behind the wall. **YOU COULD GET AN ELECTRICAL SHOCK if you contact electrical wire** with the drill bit.
- Locate and disconnect the power to any electrical circuits that could be affected by installing this oven.

IF YOU DO NOT DISCONNECT THE POWER, YOU COULD GET AN ELECTRICAL SHOCK.

⚠ WARNING

To avoid personal injury, wear gloves when handling the metal parts. Parts are sharp and can cause cuts and abrasions.

SAMSUNG

Abt Model: MATK8020SS

NV51K7770SS

5.1 cu. ft. Single Wall Oven

Features

- 6 Oven Modes including Steam Bake and Steam Roast
- 5.1 cu. ft. Capacity
- Gourmet Cook
- Dual Convection
- WiFi Connectivity
- WiFi-Enabled Temperature Probe
- Signature LED Lights
- Soft-Close Door
- 3 Heavy-Duty Racks including a Gliding Rack
- Blue LED Illuminated Knobs
- Broil Element
- Smart Control Key
- 6 Rack Positions
- Drop-Down Door Design
- LED Display

Convenience

- Hidden Heating Element
- Rapid Preheat
- Sabbath Mode
- Hybrid and Self Clean
- Delay Start
- Proofing
- Warming Mode
- Kitchen Timer
- Child Safety Lock
- Convection Conversion

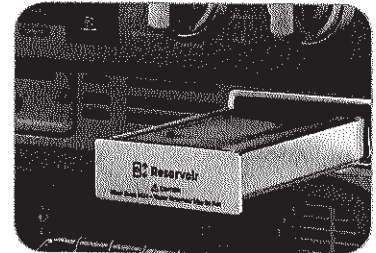
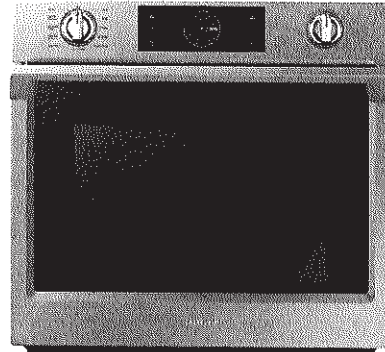

Steam Cook

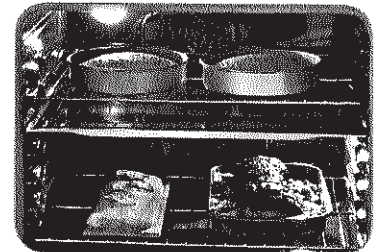

Flex Duo™

Available Colors



Stainless Steel (shown)



Black Stainless Steel

Signature Features

STEAM COOK

- Delivers moisture at precise times for a crisp, browned outside and tender inside.

DIGITAL-ANALOG CONTROLS

- The ultimate interface, a combination of analog-knobs and a digital touch screen.

FLEX DUO™

- Cook two dishes at different temperatures simultaneously with the Smart Divider.

SAMSUNG

NV51K7770SS

5.1 cu. ft. Single Wall Oven

Cabinet Dimensions

Single Oven Installed in Cabinet

*Junction Box

**Allow a minimum of 22" for clearance to adjacent corners, drawers, walls, etc. when door is open.

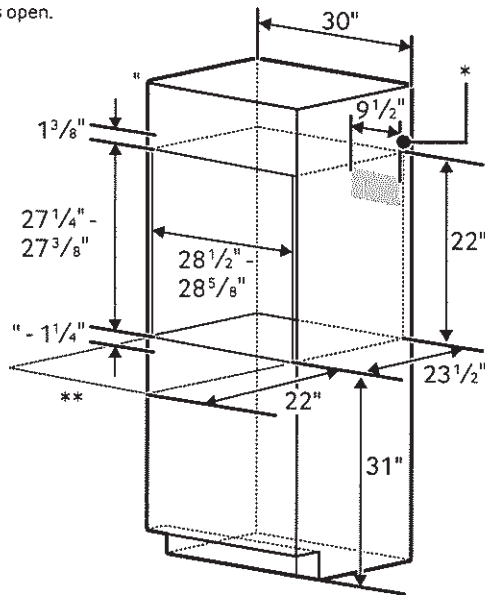

Convection Wall Oven

- Hidden Bake Element
- Bake: 175°F–550°F
- Convection Bake: 175°F–550°F
- Convection Roast: 175°F–550°F
- Broil: Low-High
- Steam Bake: 230°F–550°F
- Steam Roast: 230°F–550°F
- Proofing
- Sabbath Mode

Warranty

One (1) Year All Parts and Labor

Product Dimensions & Weight (WxHxD)

Outside (Max) Wall Oven Dimensions:

28³/₄" x 27⁵/₈" x 24⁷/₁₆"

Wall Oven Cut-Out Dimensions:

28¹/₂" x 27¹/₄" x 23¹/₂"

Weight: 149.9 lbs.

Shipping Dimensions & Weight (WxHxD)

Dimensions:

33¹/₂" x 33³/₄" x 29¹³/₁₆"

Weight: 176.4 lbs.

Product Dimensions

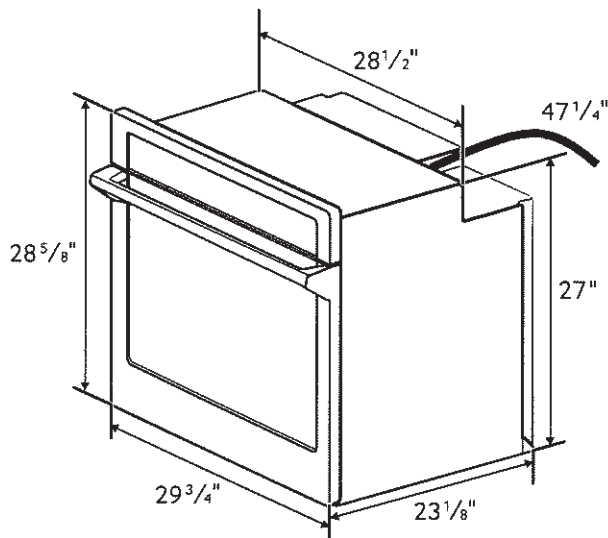

Color	Model #	UPC Code
Stainless Steel	NV51K7770SS	887276181691
Black Stainless Steel	NV51K7770SG	887276181752

KWRATING	
240V	6.2
208V	4.7
BREAKER SIZE	
240V	30 Amps
208V	30 Amps

SAMSUNG

Actual color may vary. Design, specifications, and color availability are subject to change without notice. Non-metric weights and measurements are approximate.

©2016 Samsung Electronics America, Inc. 85 Challenger Road, Ridgefield Park, NJ 07660. Tel: 800-SAMSUNG; samsung.com. Samsung is a registered trademark of Samsung Electronics Co., Ltd.