

PRE-Sales Selection Sheet
Checklist

1 A OF 35

LOT 190D-26 Model: 20-1606 A The Grassfield

PURCHASERS: Manoj Kumar Malhotra/Anju Malhotra

VENDOR: Heathwood Homes (Huron) Limited

- FINISHED BASEMENT
- COLD CELLAR

UPGRADED / MODIFIED ELEVATION

- CORNER UPGRADE
- REAR UPGRADE

CEILING UPGRADE - SMOOTH

- MAIN FLOOR
- SECOND FLOOR
- BASEMENT

ADDITIONAL ROUGH-INS

- 200 AMP SERVICE
- WET BAR ROUGH-IN
- HUMIDIFIER
- AIR CONDITIONING

GAS ROUGH-IN

- STOVE
- DRYER
- BBQ
- ADDITIONAL FIREPLACE

KITCHEN: HOODFAN VENTING SIZE

- 6 IN ROUND DUCT
- 7 IN ROUND DUCT

FULL BASEMENT STAIRS:	N/A
UPPER BASEMENT STAIRS:	All Oak
LOWER BASEMENT STAIRS:	Carpet Grade
MAIN STAIRS:	All Oak
MEDIA STAIRS (if applicable):	N/A
LOFT STAIRS (if applicable):	N/A

Aug 4/20 _____
Date Purchaser: *Signature on file*

Aug 4, 20 _____
Date Decor Consultant: *Signature*

* APPROVED *

Date Purchaser:

-08- 13 2020 _____
Date Heathwood Homes (Huron) Limited

Approved

Locked Date:



Sales Selection Sheet

Wallaceton
SCHEDULE 'E'

1 B OF 35

PURCHASERS: Manoj Kumar Malhotra and Anju Malhotra

TEL:

LOT / UNIT 190D-26	PHASE 1	MODEL 20-1606 A The Grassfield	
-----------------------	------------	-----------------------------------	--

It is herein understood and agreed between the undersigned parties hereto that the following changes shall be made to the above mentioned Agreement of Purchase and Sale in accordance with the agreement and except for such changes noted below, all other terms and conditions in the Agreement of Purchase and Sale shall remain as stated herein: It is further understood that and agreed that all changes and additions shall be installed as per builder's specifications, location and available selections. The Purchaser hereby agrees to purchase the following extras:

APPLIANCES

1	SCHEDULE E- FIVE APPLIANCES: SS FRIDGE, STOVE, DISHWASHER; WHITE FRONT LOADER WASHER/DRYER- TOWNHOMES SPECS PAGES 21-35	Qty: 1	
31,428	Note:		

Sub Total
HST
Total

1. This Sales Selection Sheet when properly executed forms part of our Agreement of Purchase and Sale.
2. All extras and upgrades listed above are subject to Construction Progress and Architectural and Municipal requirements.
3. In the event the Vendor is unable to incorporate the work approved above in the construction of the house for any reason whatsoever, the Vendor will not be liable to the Purchaser in any way. The monies paid for any changes or optional extras not proceeded with shall be returned to the Purchaser, without interest. The cost of options or extras is non-refundable in all other circumstances. If for any reason whatsoever the Agreement of Purchase and Sale is not completed, the total cost of work approved above will be retained by the Vendor.
4. The Vendor reserves the right to substitute above materials and equipment with that of equal or better quality.
5. Purchaser acknowledges that items may not be exactly as shown. Variations from the Vendor's samples may occur in finished materials due to normal production processes. Vendor is not responsible for shade difference which may occur from different dye lots or wood grains. Variations from the Vendor's samples will occur with natural materials such as wood, marble, granite, hardwood and brick.
6. The Vendor reserves the right to select Grout & Thresholds that best suits the Tile selected.
7. Selections will not be processed unless signed by Heathwood Homes Head Office.
8. The selections made on this schedule are final and cannot be changed once submitted.
9. The Purchaser has checked and acknowledges the accuracy of this schedule.

Payment Summary	
<u>Paid By</u>	<u>Amount</u>
<u>Total Payment:</u>	

PURCHASER: Manoj Kumar Malhotra 13-Aug-20 DATE IRIT SALEM 13-Aug-20 DATE
 Decor Consultant

PURCHASER: Anju Malhotra 13-Aug-20 DATE - APPROVED -
-08-13-2020 mRosen
 Date Approved Heathwood Homes (Huron) Limited

TAX#:1

PREPARED BY: Marilyn Rosen

PE 412-1

Customer Colours

136

Manoj Kumar Malhotra/Anju Malhotra
 Project: Wallaceton
 Unit: 190D-26, Phase: 1
 Model: 20-1606 A The Grassfield

Created: 6/25/2020 09:08:51

Locked:

Closed:

2 of 35

Kitchen

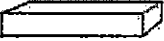
Cabinet Colour/Style	9111	VIKING III SIMCOE ORCHID 3DL ***STD***
Countertop	9069	MSI Quartz GROUP 1 ICED WHITE ***STD***
Countertop Edge	4010	SINGLE POLISHED STRAIGHT EDGE 3/4 INCH ***STD*** 
Cabinet Hardware	7667	12881-HARDWARE ***STD***
Island Cabinet Colour/Style	9111	VIKING III SIMCOE ORCHID 3DL ***STD***
Island Countertop	9069	MSI Quartz GROUP 1 ICED WHITE ***STD***
Backsplash	1111	N/A *****
Backsplash Grout	1111	N/A *****
Backsplash Tile Pattern	1111	N/A *****
HoodFan	1111	AV1308 Air King 30 <i>PAGE 20</i>
Appliances	1111	Purchasers have been advised: standard fridge opening is a minimum 37 3/8 x 73 3/8". Ice Waterline Rough-In is included.
Appliances	1111	Standard stove opening is 30" and standard dishwasher opening is 24". Any gas stove will require backsplash or stainless steel backing to avoid fire hazards.
Appliances	1111	Purchasers acknowledge: Heathwood Homes and its contractors will not be responsible for any kitchen cabinet changes due to appliances dimension changes after
Comment		

Kitchen/Breakfast

Flooring	1111	GE.BY.AZR.1313 New Byzantine Azzuro 13
Floor Tile Grout	2225	Grout-(27) Silver ***STD***
Floor Tile Pattern	3000	STANDARD SQUARE ***STD***

Manoj Kumar Malhotra/Anju Malhotra
Project: Wallaceton
Unit: 190D-26, Phase: 1
Model: 20-1606 A The Grassfield

Created: 6/25/2020 09:08:51
Locked:
Closed:

3 of 35

Comment

Foyer

Flooring 3000 GE.BY.AZR.1313 New Byzantine Azzuro 13

Floor Tile Grout 2225 Grout-(27) Silver ***STD***

Floor Tile Pattern 3000 STANDARD SQUARE ***STD***

Comment

Laundry Room

Flooring 3000 GE.BY.AZR.1313 New Byzantine Azzuro 13

Floor Tile Grout 2225 Grout-(27) Silver ***STD***

Floor Tile Pattern 3000 STANDARD SQUARE ***STD***

Comment

Mud Room

Flooring 3000 GE.BY.AZR.1313 New Byzantine Azzuro 13

Floor Tile Grout 2225 Grout-(27) Silver ***STD***

Floor Tile Pattern 3000 STANDARD SQUARE ***STD***

Comment

Customer Colours

136

Manoj Kumar Malhotra/Anju Malhotra
Project: Wallaceton
Unit: 190D-26, Phase: 1
Model: 20-1606 A The Grassfield

Created: 6/25/2020 09:08:51

Locked:

Closed:

4 of 35

Powder Room

Flooring GE.BY.AZR.1313 New Byzantine Azzuro 13

Floor Tile Grout Grout-(27) Silver ***STD***

Floor Tile Pattern STANDARD SQUARE ***STD***

Plumbing Fixture (Colour) Plumbing Fixtures-WHITE ***STD***

Comment

Hall

Flooring GE.BY.AZR.1313 New Byzantine Azzuro 13

Grout Grout-(27) Silver ***STD***

Floor Tile Pattern STANDARD SQUARE ***STD***

Comment

Great Room

Flooring Red Oak Pearl-Vintage Engineered-IRONGATE-3/4 inch x 3 1/4 inch ***STD***

Comment

Upper Hall

Flooring DY 89418 -Dynasty Tex-BLACK ICE-40 oz Poly***STD***

Comment

Customer Colours

136

Manoj Kumar Malhotra/Anju Malhotra
Project: Wallaceeton
Unit: 190D-26, Phase: 1
Model: 20-1606 A The Grassfield

Created: 6/25/2020 09:08:51

Locked:

Closed:

5 of 35

Finished Basement (Rec) Room/Hall

Flooring 9248 DY 89418 -Dynasty Tex-BLACK ICE-40 oz Poly***STD***

Comment

Master Bedroom

Flooring 9248 DY 89418 -Dynasty Tex-BLACK ICE-40 oz Poly***STD***

Comment

Bedroom 2

Flooring 9248 DY 89418 -Dynasty Tex-BLACK ICE-40 oz Poly***STD***

Comment

Bedroom 3

Flooring 9248 DY 89418 -Dynasty Tex-BLACK ICE-40 oz Poly***STD***

Comment

Master Ensuite

Cabinet Colour/Style 9158 Viking III-SIMCOE-NAVY BLUE-3DL ***STD***

Countertop 8822 4924-38-Countertop-WHITE CARRARA-Wilsonart
STD

Countertop Edge 1111 N/A *****

Cabinet Hardware 7667 12881-HARDWARE ***STD***

Floor Tile 7667 GE.BY.AZR.1313 New Byzantine Azzuro -13

Floor Tile Grout 2225 Grout-(27) Silver ***STD***

Customer Colours

Manoj Kumar Malhotra/Anju Malhotra
 Project: Wallaceton
 Unit: 190D-26, Phase: 1
 Model: 20-1606 A The Grassfield

Created: 6/25/2020 09:08:51

Locked:

Closed:

6 of 35

Floor Tile Pattern STANDARD SQUARE ***STD***

Shower Floor Tile OD.ON.SWT.0202.MT.N-Ontario Series Mosaic-Snow White Matte-2 x 2 ***STD***

Shower Floor Tile Grout Grout-(00) White ***STD***

Shower Floor Tile Pattern STANDARD SQUARE ***STD***

Shower Wall Tile QT.SP.DGR.0810-Splendour-Dark Grey-8 inch x 10 inch ***STD***

Shower Wall Tile Grout Grout-(00) White ***STD***

Shower Wall Tile Pattern VERTICAL STACKED ***STD***

Shower Jamb(s) and Sill(s) Shower Jamb / Sill-Thassos White ***STD***

Plumbing Fixture (colour) Plumbing Fixtures-WHITE ***STD***

Comment

Main Bathroom

Cabinet Colour/Style Viking III-SIMCOE-NAVY BLUE-3DL ***STD***

Countertop 4924-38-Countertop-WHITE CARRARA-Wilsonart ***STD***

Countertop Edge N/A *****

Cabinet Hardware 12881-HARDWARE ***STD***

Flooring GE.BY.AZR.1313 New Byzantine Azzuro 13

Floor Tile Grout Grout-(27) Silver ***STD***

Floor Tile Pattern STANDARD SQUARE ***STD***

Manoj Kumar Malhotra/Anju Malhotra
 Project: Wallaceton
 Unit: 190D-26, Phase: 1
 Model: 20-1606 A The Grassfield

Created: 6/25/2020 09:08:51

Locked:

Closed:

7 OF 35

Wall Tile 5420 QT.SP.DGR.0810-Splendour-Dark Grey-8 inch x 10 inch
STD

Wall Tile Grout 2226 Grout-(00) White ***STD***

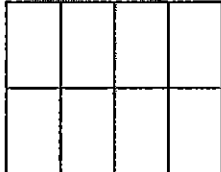
Main Bathroom Tile Pattern 3090 VERTICAL STACKED ***STD***

Plumbing Fixture (Colour) 1737 Plumbing Fixtures-WHITE ***STD***

Comment

Finished Basement Bathroom

Cabinet Colour/Style 9158 Viking III-SIMCOE-NAVY BLUE-3DL ***STD***

Countertop 8822 4924-38-Countertop-WHITE CARRARA-Wilsonart
STD

Countertop Edge 1111 N/A *****

Cabinet Hardware 7667 12881-HARDWARE ***STD***

Flooring 7667 GE.BY.AZR.1313 New Byzantine Azzuro 13

Floor Tile Grout 2225 Grout-(27) Silver ***STD***

Floor Tile Pattern 3000 STANDARD SQUARE ***STD***

Shower Floor Tile 8661 OD.ON.SWT.0202.MT.N-Ontario Series Mosaic-Snow
White Matte-2 x 2 ***STD***

Shower Floor Tile Grout 2226 Grout-(00) White ***STD***

Shower Floor Tile Pattern 3000 STANDARD SQUARE ***STD***

Shower Wall Tile 5420 QT.SP.DGR.0810-Splendour-Dark Grey-8 inch x 10 inch
STD

Customer Colours

Manoj Kumar Malhotra/Anju Malhotra
Project: Wallaceton
Unit: 190D-26, Phase: 1
Model: 20-1606 A The Grassfield

Created: 6/25/2020 09:08:51

Locked:

Closed:

8 OF 35



Shower Wall Tile Grout 2226 Grout-(00) White ***STD***

Shower Wall Tile Pattern 3090 VERTICAL STACKED ***STD***

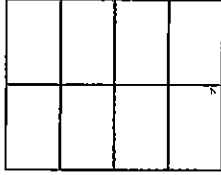

Shower Jamb(s) 8923 Shower Jamb / Sill-Thassos White ***STD***

Plumbing Fixture (Colour) 1737 Plumbing Fixtures-WHITE ***STD***

Comment

Great Room Fireplace

Type 8865 Dimplex-Electric Fireplace-PF3033HL ***STD***

Mantle 9114 NF 15-Paint Grade Mantle- Cabinet (Per Plan)-WHITE ***STD***
PAGE 16

Surround Opt. 1111 N/A *****

Note 1111 Purchasers have been advised: heat from the FP can damage TV above a FP and items placed on mantle.

Note 1111 Heathwood and its contractors will not be liable for any damage on items placed/installed above a FP after closing.

Comment

Basement Stairs

Type 1714 Carpet Grade Stairs ***STD BASEMENT STAIRS***

Colour 7912 Irongate (Gryphon) STAIN TO COMPLIMENT HARDWOOD AND WILL VARY FROM FLOORING

Carpet Runner 1111 N/A *****

Handrail/Pickets/Post Type 9119 Handrail only on closed walls (one or two sides per building code) ***STD***

Handrail/Pickets/Post Colours 1729 Carpet Grade-Stain handrail, pickets, stringers, nosing_pos

Carpet 9248 DY 89418 -Dynasty Tex-BLACK ICE-40 oz Poly***STD***

Custom Stain/Paint 1111 N/A *****

Comment

Customer Colours

Manoj Kumar Malhotra/Anju Malhotra
Project: Wallaceton
Unit: 190D-26, Phase: 1
Model: 20-1606 A The Grassfield

Created: 6/25/2020 09:08:51

Locked:

Closed:

9 of 35

Comment

Basement Stairs Landings (Upper and Lo

Flooring 7498 Red Oak Pearl-Vintage Engineered-IRONGATE-3/4 inch x 3 1/4 inch ***3***

Comment

Main Stairs

Type 1712 Oak Stairs ***STD MAIN STAIRS***

Colour 7912 Irongate (Gryphon) STAIN TO COMPLIMENT HARDWOOD AND WILL VARY FROM FLOORING

Carpet Runner 1111 N/A *****

Handrail/Pickets/Posts Type 7652 1 5/16 inch Square pickets with 3 1/2" Square/Cap Post(s)-ALL OAK ***STD***

Handrail/Pickets/Posts Colour 1728 Oak Grade-Stain handrail,oak pickets,stringers,treads,risers

Custom Stain/Paint 1111 N/A *****

Comment

Main Stairs Landing(s)

Flooring 7498 Red Oak Pearl-Vintage Engineered-IRONGATE-3/4 inch x 3 1/4 inch ***STD***

Comment

Throughout

Walls - Paint Colour 1717 22-Wall-WARM GREY ***STD***

Underpad 1079 500 Series-Underpad ***STD***

Thresholds 2232 Metal Thresholds ***STD***

Switches and Plug 5796 Decora White Switches and Plugs ***STD***

Trim Size 8705 4 1/4 Baseboard and 2 1/4 Casings ***STD***

Trim Paint Colour

Customer Colours

136

Manoj Kumar Malhotra/Anju Malhotra
Project: Wallaceton
Unit: 190D-26, Phase: 1
Model: 20-1606 A The Grassfield

Created: 6/25/2020 09:08:51

Locked:

Closed:

10 of 35

Trim - Paint Colour 1716 Trim-WHITE ***STD***

Comment

[Empty comment box]

Purchaser: Manoj Kumar Malhotra 4 Aug 2020
Date

[Signature] Aug 20, 20
Decor Consultant Date

Purchaser: Anju Malhotra Aug 4, 2020
Date

[Signature]
Wallaceton
APPROVED
-08- 13 2020
Date Approved



Sales Selection Sheet

Wallaceton

11 OF 35

PURCHASERS: Manoj Kumar Malhotra and Anju Malhotra

TEL:

LOT / UNIT 190D-26	PHASE 1	MODEL 20-1606 A The Grassfield
-----------------------	------------	-----------------------------------

It is herein understood and agreed between the undersigned parties hereto that the following changes shall be made to the above mentioned Agreement of Purchase and Sale in accordance with the agreement and except for such changes noted below, all other terms and conditions in the Agreement of Purchase and Sale shall remain as stated herein: It is further understood that and agreed that all changes and additions shall be installed as per builder's specifications, location and available selections. The Purchaser hereby agrees to purchase the following extras:

ELECTRICAL

1 189,45C 30,510	ELECTRICAL - CEILING ROUGH-IN (CAPPED) Note: GREAT ROOM: USE EXISTING SWITCH PLUG SEE SKETCH # 2 PAGE# 14	Qty: 1
2 189,44E 30,512	ELECTRICAL - EXTRA WALL INTERIOR OUTLET ON EXISTING CIRCUIT (DOES NOT INCLUDE KITCHEN OUTLETS) Note: GREAT ROOM: TO BE INSTALL 170" FROM FLOOR IN THE CENTRE OF THE FICE PLACE SEE SKETCH# 2 PAGE# 14	Qty: 1

Sub Total
HST
Total

- This Sales Selection Sheet when properly executed forms part of our Agreement of Purchase and Sale.
- All extras and upgrades listed above are subject to Construction Progress and Architectural and Municipal requirements.
- In the event the Vendor is unable to incorporate the work approved above in the construction of the house for any reason whatsoever, the Vendor will not be liable to the Purchaser in any way. The monies paid for any changes or optional extras not proceeded with shall be returned to the Purchaser, without interest. The cost of options or extras is non-refundable in all other circumstances. If for any reason whatsoever the Agreement of Purchase and Sale is not completed, the total cost of work approved above will be retained by the Vendor.
- The Vendor reserves the right to substitute above materials and equipment with that of equal or better quality.
- Purchaser acknowledges that items may not be exactly as shown. Variations from the Vendor's samples may occur in finished materials due to normal production processes. Vendor is not responsible for shade difference which may occur from different dye lots or wood grains. Variations from the Vendor's samples will occur with natural materials such as wood, marble, granite, hardwood and brick.
- The Vendor reserves the right to select Grout & Thresholds that best suits the Tile selected.
- Selections will not be processed unless signed by Heathwood Homes Head Office.
- The selections made on this schedule are final and cannot be changed once submitted.
- The Purchaser has checked and acknowledges the accuracy of this schedule.

Payment Summary	
Paid By	Amount
Total Payment: _____	

PURCHASER: Manoj Kumar Malhotra
DATE: 04-Aug-20

[Signature]
Decor Consultant
DATE: 04-Aug-20

PURCHASER: Anju Malhotra
DATE: 04-Aug-20

- APPROVED -
-08- 13 2020
[Signature]
Date Approved Heathwood Homes (Huron) Limited

TAX#:1
PREPARED BY: Irit Salem

Customer Colours

136

Manoj Kumar Malhotra/Anju Malhotra
Project: Wallace-ton
Unit: 190D-26, Phase: 1
Model: 20-1606 A The Grassfield

Created: 6/25/2020 09:08:51

Locked:

Closed:

12 OF 35

Trim - Paint Colour

1/16

Trim-WHITE "STD"

Comment

[Empty comment box]

Purchaser:

Manoj Kumar Malhotra 4 Aug 2020
Date

[Signature] Aug 4. 20
Decor Consultant Date

Purchaser:

Anju Malhotra 4 Aug 2020
Date

[Signature]
Wallaceton
-08- 13 2020
Date Approved

APPROVED

UK-75 WALLACETON
20-1606 ELEV A
LOT 190D-26
THE GRASSFIELD

13 of 35

THE GRASSFIELD

ELEVATION A | 1,986 SQ. FT.

Includes 380 square feet of finished lower level

20-1606 ELEV. A

WALLACETON
EST. 1870

Sketch #1

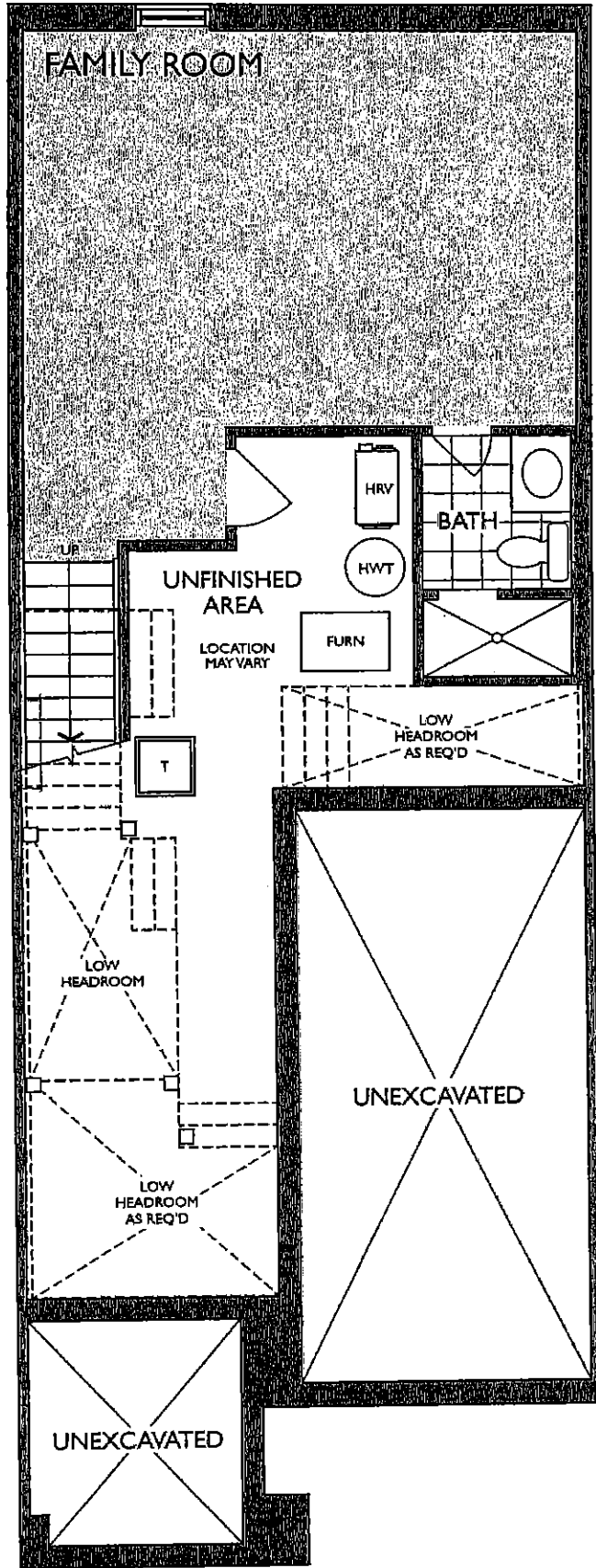

LOWER LEVEL
ELEVATION A & B

Handwritten signature

UK-75 WALLACETON
20-1606 ELEV A
LOT 190D-26
THE GRASSFIELD

14 of 35

THE GRASSFIELD

ELEVATION A | 1,986 SQ. FT.

Includes 380 square feet of finished lower level

WALLACETON
EST. 1870

20-1606 ELEV. A

Sketch #2

ELECTRICAL
OUTLET
70" +/-
FROM FLOOR

R/I CAPLIGHT
R +/-
ON EXISTING
SWITCHED PLUG

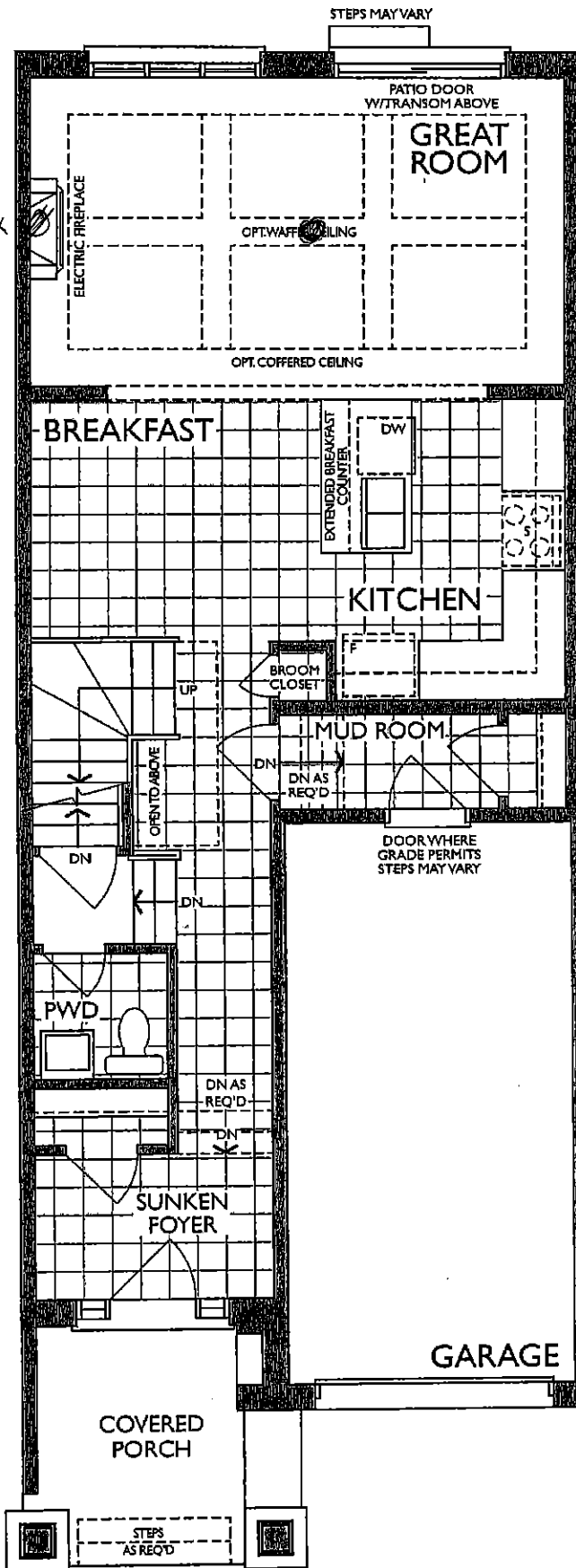

MAIN FLOOR
ELEVATION A

Handwritten signature

UK-75 WALLACETON
20-1606 ELEV A
LOT 190D-26
THE GRASSFIELD

15 of 35

THE GRASSFIELD

ELEVATION A | 1,986 SQ. FT.

Includes 380 square feet of finished lower level

WALLACETON
EST. 1870

20-1606 ELEV. A

Sketch #3

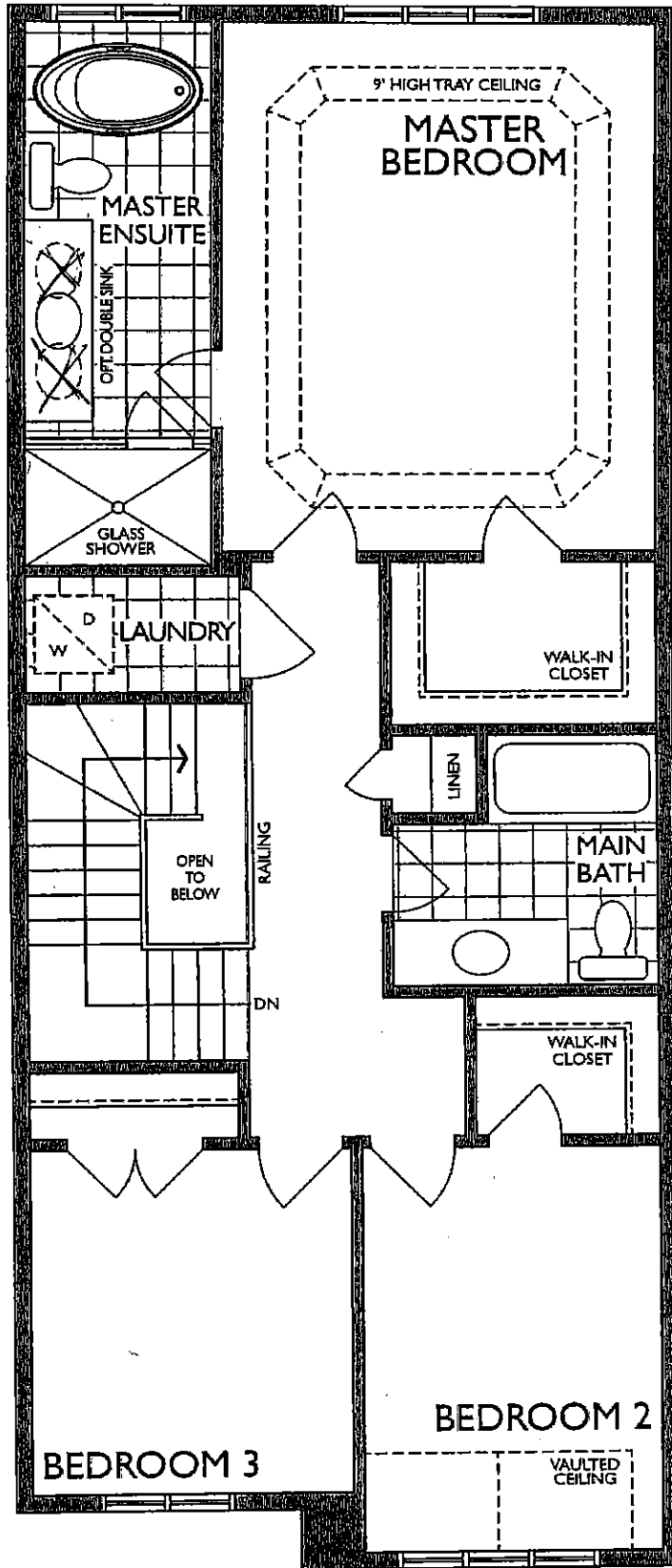

SECOND FLOOR
ELEVATION A

Handwritten signature

July 7, 2020

UK 75- WALLACETON
20-1606 ELEV. A
THE GRASSFIELD
LOT 190D-26

16 of 35

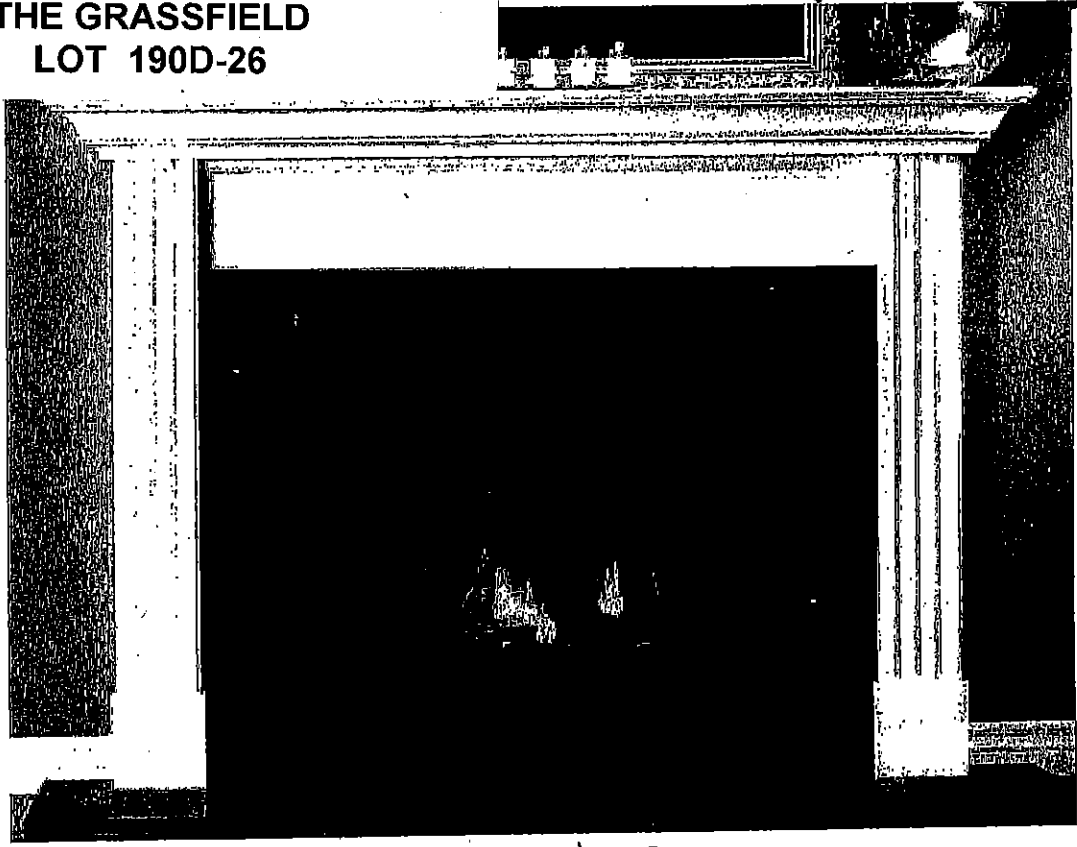

CABINET.

STANDARD NF 15 Mantel

Clean apron finish with fluted legs

WHITE PAINT GRADE FINISH

(PICTURE SHOWN WITH UPGRADE SURROUND AND HEARTH -PRICED SEPARATELY)

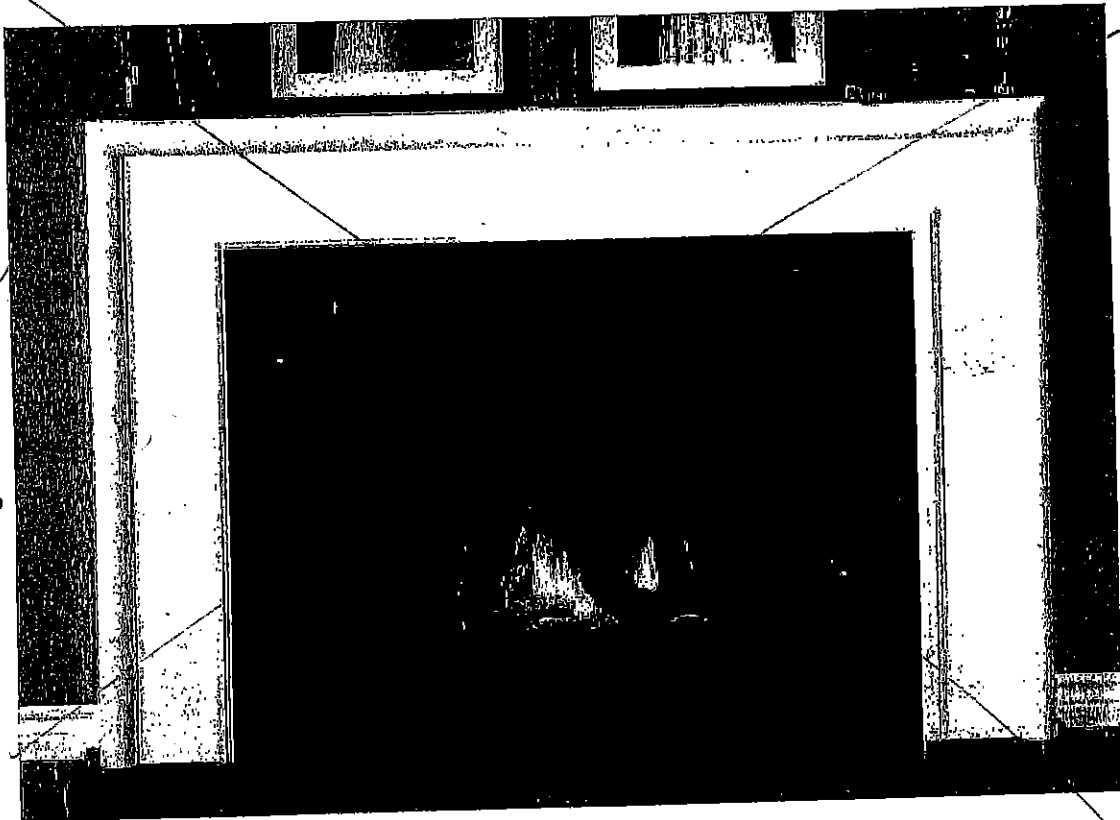

STANDARD NF 17 Mantel

WHITE PAINT GRADE FINISH

(PICTURE SHOWN WITH UPGRADE SURROUND AND HEARTH -PRICED SEPARATELY)

A. Allen

UK-75 WALLACETON
 20-1606 ELEV A
 LOT 190D-26
 THE GRASSFIELD

17 of 35

Regence STANDARD KITCHEN SINK ND1831UA/9

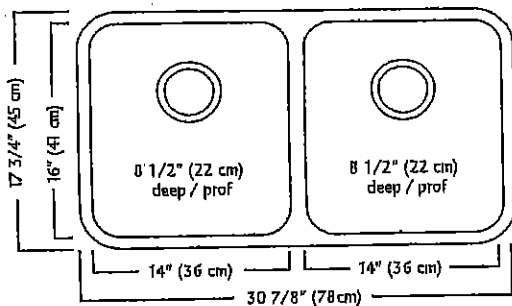
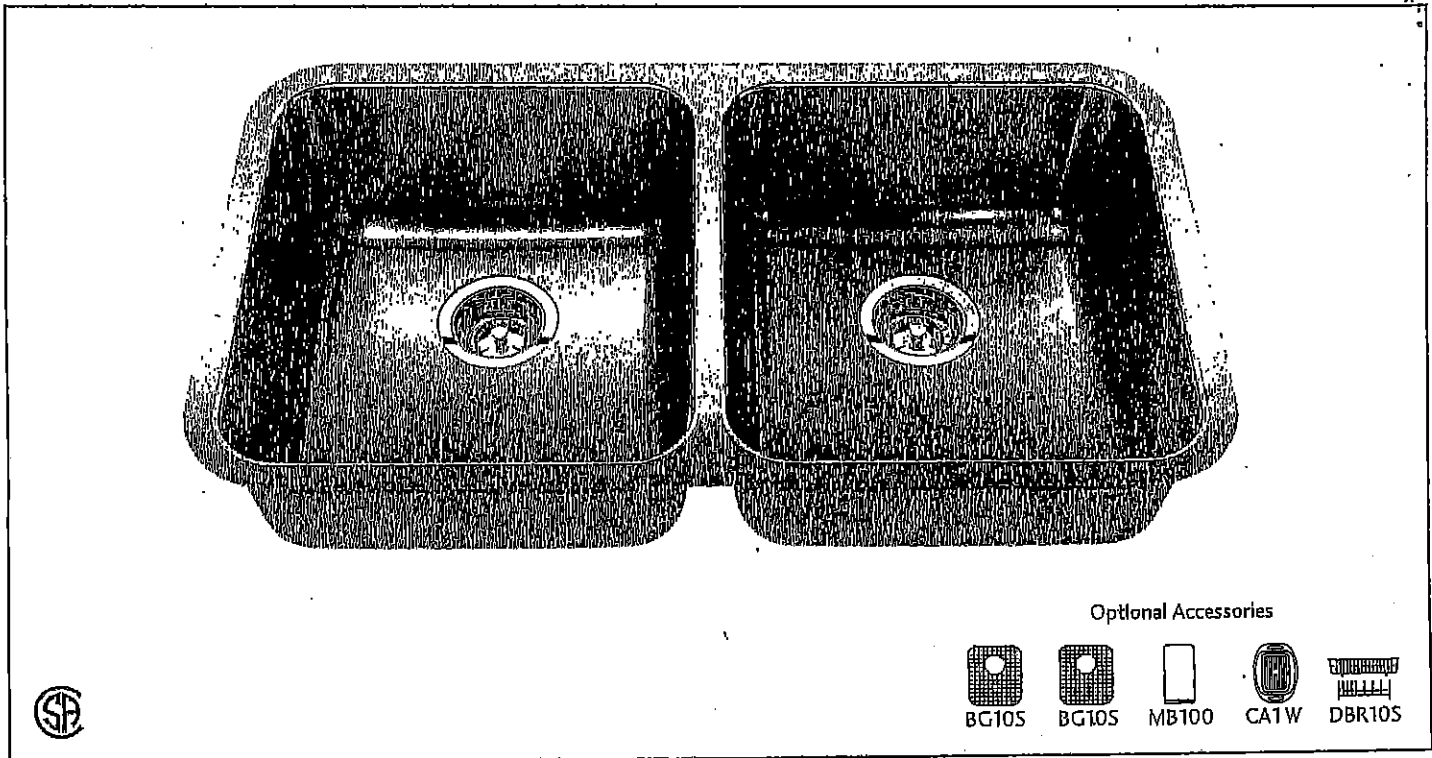

ND1831UA/9 SPECIFICATION

Model ND1831UA/9 is a double (two equal size) bowl undermount sink manufactured by Franke Kindred Canada Limited from 18 gauge stainless steel. Product has silk finished rims and linear brush finished bowls. Sink is fully undercoated. Basket strainer waste fittings (3 1/2", 89 mm) are included. Sink is backed with a limited lifetime warranty.

- O.D. 17 3/4" x 30 7/8" x 8 1/2" (45 x 78 x 22 cm)
- Recommended for minimum 36" cabinet

Franke Kindred Canada Limited
 P.O. Box 190, 1000 Franke Kindred Road, Midland, Ontario, Canada, L4R 4K9 Phone: 866-687-7465 Fax: 800-361-8408

AM

UK-75 WALLACETON
20-1606 ELEV A
LOT 190D-26
THE GRASSFIELD

18 of 35

STANDARD KITCHEN FAUCET

Align

Modern

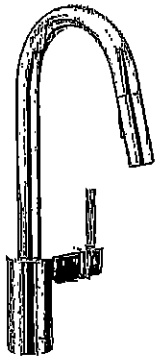

Single Handle Pull-Down Kitchen
Faucet*

Model 7565†

AS

Align

UK-75 WALLACETON
20-1606 ELEV A
LOT 190D-26
THE GRASSFIELD

19 of 35

Chateau

Transitional

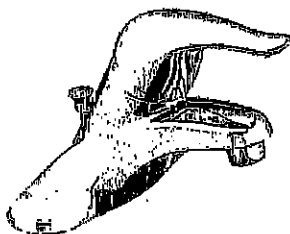

Lavatory Faucet with Pop-Up Drain
Model L4621†

VANITY SINKS AND PEDESTAL

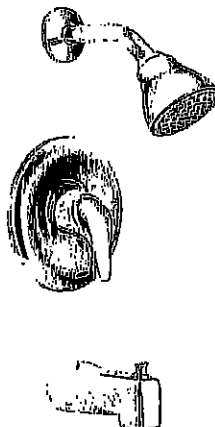

Posi-Temp® Pressure Balancing Tub/Shower
Model 62320 / TL183†

OR

Posi-Temp Valve and Tub/Shower Trim
with Eco-Performance Easy Clean® XL

Model 62320 / TL183EP†

(TL183EP not available in BC)

SHOWER AND 5' TUB FAUCETS



2 Handle Roman Tub with 9" Spout
Model 4796 / T990†

FREESTANDING TUB FAUCETS

AM

UK 75- WALLACETON
 20-1606 ELEV. A
 THE GRASSFIELD
 LOT 190D-26

20 of 35

HOOD FAN
 WALLACETON TOWNHOMES



SPECIFICATIONS
AV SERIES
 RANGE HOODS

HVI CERTIFIED 2100
 180 CFM/7.0 Sones @ 0.10" SP. Horizontal
 180 CFM/7.5 Sones @ 0.10" SP. Vertical

Dimensions

Overall bottom projection - 18 3/8"
 Overall top projection - 12"
 Height - 6"
 Available widths: 21", 24", 30", 36" & 42"

Hood Body

Stainless Steel: 24 gauge, grade 430 stainless steel.
 Painted: 23 gauge cold rolled commercial grade (CRCQ) steel, auto welded, coated with a baked enamel finish.

Motor

2 speed, single coil, thermally protected, permanently lubricated.
 Rated 120 volts, 60 hz. Complete with 200°C lead wires

Lighting

Single 60 watt cook light capacity (bulb not included).

Ducting Options

Horizontal ducting: 3 1/4"x10" (duct adapter and damper included).
 Vertical ducting: 3 1/4"x10" (duct adapter and damper included).
 Vertical ducting: 7" round (duct adapter and damper not included).
 Ductless: removable front vent (charcoal filter not included).

Fan Blade

One piece polymeric, electronically balanced blade. 6 5/8" diameter with 5 paddles.

Electrical connection

Hood top - 7/8" knockout hole for use with 1/2" cable clamp
 Hood back - 7/8" knockout hole for use with 1/2" cable clamp

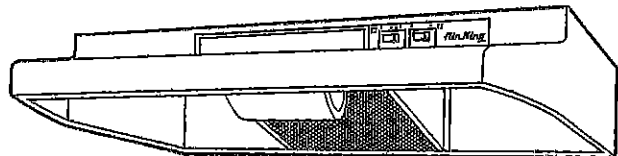

AV SERIES

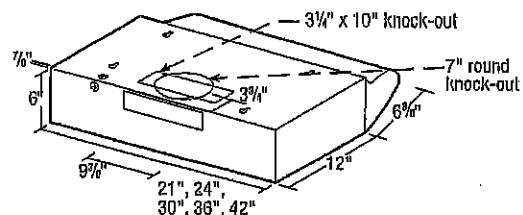

Filters

UL rated, class 2 filter.
 Grease Filter: RF35 - 8 7/8"x10 3/8" (included).
 Charcoal Filter: RF34 (not included).
 Combo Grease/Charcoal: RF55 (not included).

Available Finishes

White, Biscuit, Almond, Black & Stainless Steel.

EXPANDED PERFORMANCE										
Air Flow - CFM	Static Pressure (inches of w.g.)						Sones @ .1 SP	Fan Speed RPM	Power Watts	Amps
	0	0.05	0.1	0.15	0.2	0.25				
Vertical Ducting High	246	232	218	203	181	147	7.5	2973	87.0	2.1
Horizontal Ducting High	225	210	180	175	155	120	7.0	3024	87.0	2.1

PROJECT							ARCHITECT			
LOCATION							ENGINEER			
CONTRACTOR							SUBMITTED BY			DATE
FAN NUMBER	MODEL NUMBER	CFM	IN W.G.	RPM	WATTS	AMPS	SONES	QTY	OPTIONAL EQUIPMENT & REMARKS	



Air King: 820 Lincoln Avenue
 West Chester, Pennsylvania 19380-4466
 Tel: (610) 692-7400 • 877-304-3785
 Fax: (610) 696-8048

Canada:
 Brampton, Ontario
 Tel: 905-456-2033
 Fax: (905) 456-1015

Specifications subject to change without notice.

Updated 2-18

Handwritten signature

Whirlpool® Top Mount Refrigerator

PRODUCT MODEL NUMBERS

WRT311FZD WRT641SZD
WRT611SZD

PRODUCT DIMENSIONS

Electrical: A 115-volt, 60-Hz, AC-only, 15- or 20-amp fused, grounded electrical supply is required. It is recommended that a separate circuit serving only your refrigerator be provided. Use an outlet that cannot be turned off by a switch. Do not use an extension cord.

NOTE: Before performing any type of installation, cleaning, or removing a light bulb, turn the control (Thermostat, Refrigerator or Freezer Control depending on the model) to OFF and then disconnect the refrigerator from the electrical source. When you are finished, reconnect the refrigerator to the electrical source and reset the control (Thermostat, Refrigerator or Freezer Control depending on the model) to the desired setting. See "Using the Controls."

Water: A cold water supply with water pressure between 30 and 120 psi (207 and 827 kPa) is required to operate ice maker and water dispenser. If you have questions about your water pressure, call a licensed, qualified plumber.

IMPORTANT: The pressure of the water coming out of a reverse osmosis system going to the water inlet valve of the refrigerator needs to be between 30 and 120 psi (207 and 827 kPa).

Reverse Osmosis Water Supply: If a reverse osmosis water filtration system is connected to your cold water supply, the water pressure to the reverse osmosis system needs to be a minimum of 40 to 60 psi (276 to 414 kPa).

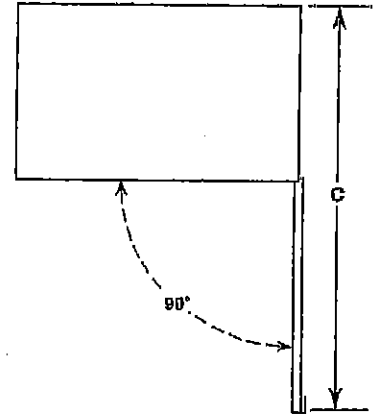
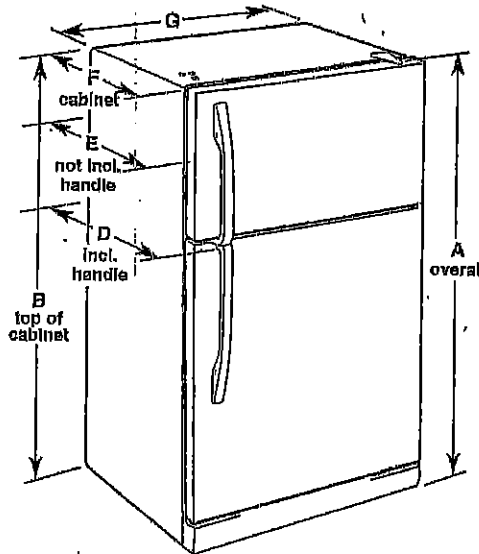

Model Number	Model Size	Reversible Door	Height - Overall "A"	Height - Top of Cabinet "B"	Depth - Door Open 90° "C"	Depth - With Handles "D"	Depth - Without Handles "E"	Depth - Cabinet Only "F"	Width - Cabinet "G"
WRT311FZD	20.5 cu. ft.	Yes	66 1/4" (168.3 cm)	65 1/2" (166.4 cm)	62 1/4" (158.1 cm)	32 3/4" (83.5 cm)	30 3/8" (77.8 cm)	28 1/2" (72.4 cm)	32 3/4" (83.2 cm)
WRT611SZD WRT641SZD	21.3 cu. ft.	Yes	66 1/4" (168.3 cm)	65 1/2" (166.4 cm)	62 1/4" (158.1 cm)	34" (86.4 cm)	32 1/2" (82.3 cm)	28 1/2" (72.4 cm)	32 3/4" (83.2 cm)

LOCATION REQUIREMENTS

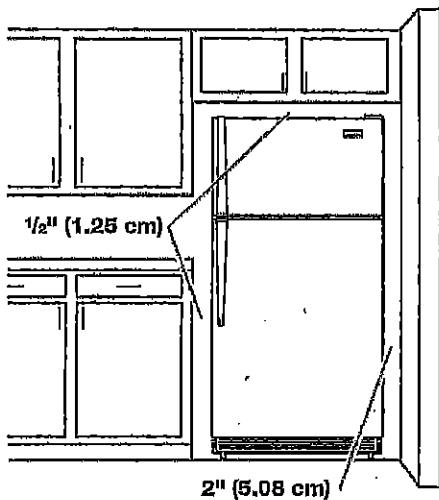

To ensure proper ventilation for your refrigerator, allow for a 1/2" (1.25 cm) space on each end and between overhead cabinets and refrigerator top. Allow at least 1" (2.5 cm) between back of cabinet and the wall. If your refrigerator has an ice maker, make sure you leave some extra space at the back for the water line connections.

If you are installing your refrigerator next to a fixed wall, leave 2" (5 cm) minimum on the hinge side (depending on your model) to allow for the door to swing open.

NOTE: This refrigerator is intended for use in a location where the temperature ranges from a minimum of 55°F (13°C) to a maximum of 110°F (43°C). The preferred room temperature range for optimum performance, which reduces electricity usage and provides superior cooling, is between 60°F (15°C) and 90°F (32°C). It is recommended that you do not install the refrigerator near a heat source, such as an oven or radiator.

A
mm

Refrigerator Door Swing Verification

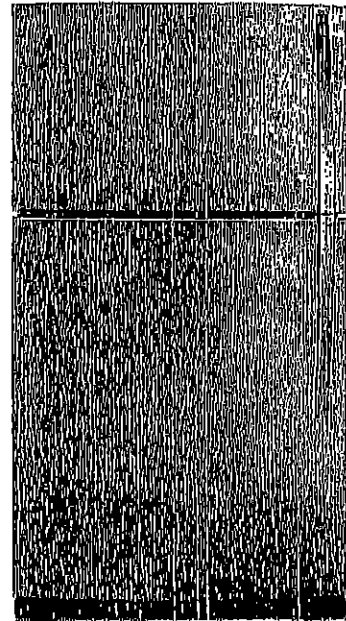
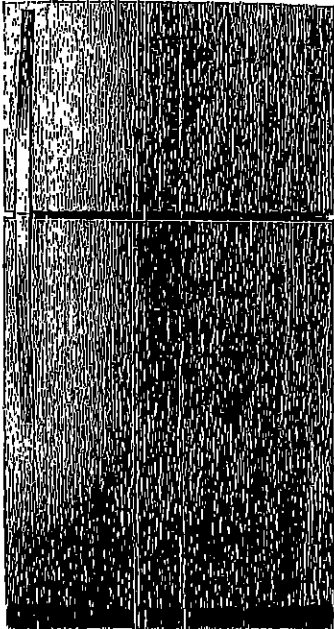
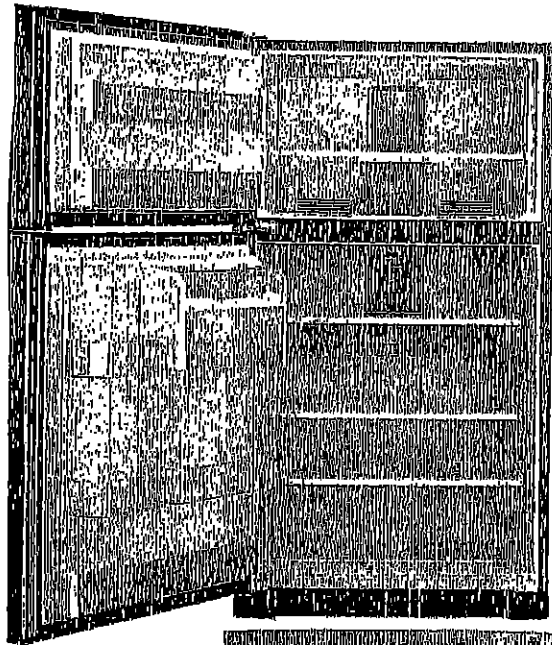
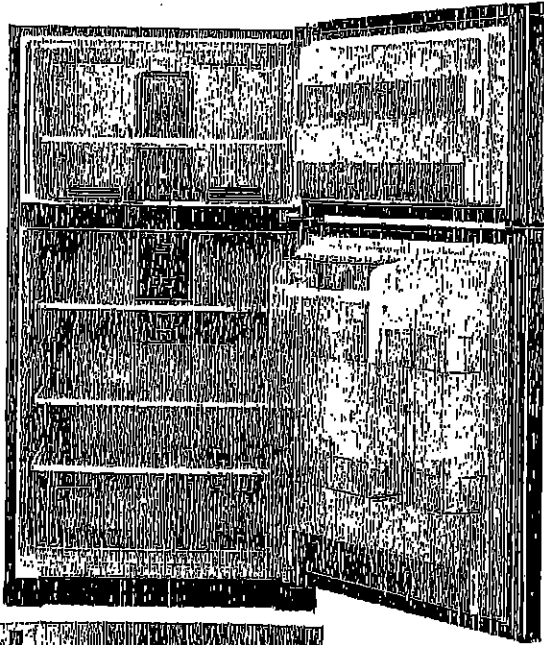

When facing the refrigerator



**RIGHT HAND
DOOR OPENING**

- Hinges on right
- Handle on left

INITIAL

**LEFT HAND
DOOR OPENING**

- Hinges on left
- Handle on right

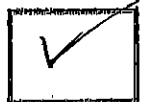

INITIAL

Please check and INITIAL your door swing selection.

UK-75 WALLACETON
20-1606 ELEV A
LOT 190D-26
THE GRASSFIELD

23 of 35

WHIRLPOOL 30" (76.0 CM) FREESTANDING ELECTRIC RANGES
Model YWFE515S0JS

5.3 cu. ft. Whirlpool® electric range with Frozen
Bake™ technology

YWFE515S0JS

Whirlpool

Home > Kitchen Appliances > Cooking Appliances > Ranges > Single Oven Ranges > YWFE515S0JS

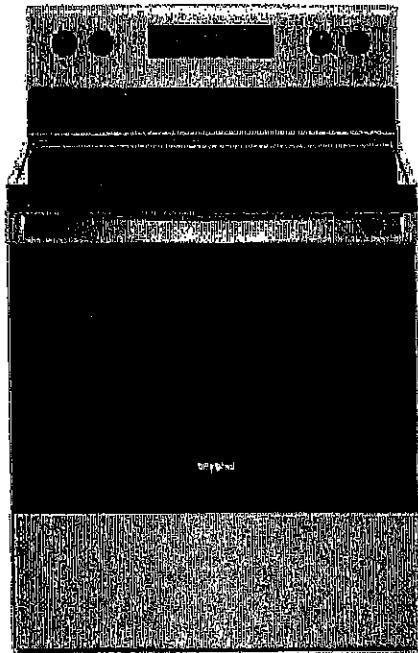

RF



A
Alu

**UK-75 WALLACETON
20-1606 ELEV A
LOT 190D-26
THE GRASSFIELD**

24 or 35

**WHIRLPOOL 30" (76.0 CM) FREESTANDING ELECTRIC RANGES
Model YWFE515S0JS**

Product Dimensions

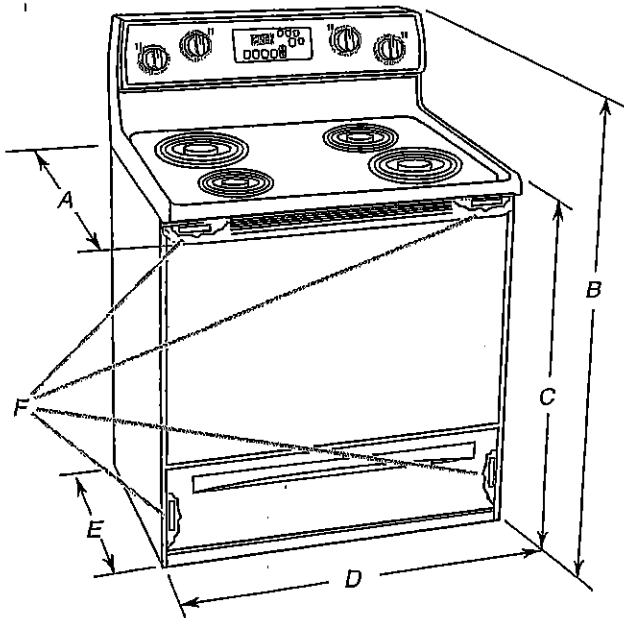

- A. 27³/₄" (70.5 cm) max. depth with handle
- B. 46⁷/₈" (119.1 cm) overall height (max.) with leveling legs screwed all the way in*
- C. 36" (91.4 cm) cooktop height (max.) with leveling legs screwed all the way in*
- D. 29⁷/₈" (75.9 cm) width
- E. 25⁵/₁₆" (64.3 cm) depth - back of range to front of cooktop**
- F. Model/serial/rating plate (located on the frame behind a top corner of the door or either side of the drawer)

IMPORTANT: Range must be level after installation. Follow the instructions in the "Level Range" section. Using the cooktop as a reference for leveling the range is not recommended.

*Range can be raised approximately 1" (2.5 cm) by adjusting the leveling legs.

**Front of door and drawer may extend further forward depending on styling.

Cabinet Dimensions

Cabinet opening dimensions shown are for 25" (64.0 cm) countertop depth, 24" (61.0 cm) base cabinet depth and 36" (91.4 cm) countertop height.

IMPORTANT: If installing a range hood or microwave hood combination above the cooking surface, follow the range hood or microwave hood combination installation instructions for dimensional clearances above the cooktop surface.

A freestanding range may be installed next to combustible walls with zero clearance.

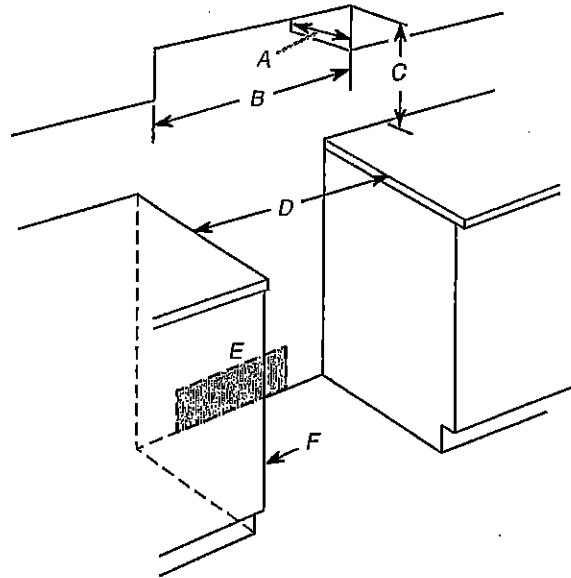

- A. 13" (33.0 cm) max. upper cabinet depth
- B. 30" (76.2 cm) min. opening width
- C. For minimum clearance to top of cooktop, see NOTE*
- D. 30" (76.2 cm) min. opening width
- E. Outlet - 8" (20.3 cm) to 22" (55.9 cm) from either cabinet, 7" (17.8 cm) max. from floor.
- F. Cabinet door or hinges should not extend into the cutout.

*NOTE: 24" (61.0 cm) minimum when bottom of wood or metal cabinet is covered by not less than 1/4" (6.4 mm) flame retardant millboard covered with not less than No. 28 MSG sheet steel, 0.015" (0.4 mm) stainless steel, 0.024" (0.6 mm) aluminum or 0.020" (0.5 mm) copper.

30" (76.2 cm) minimum clearance between the top of the cooking platform and the bottom of an uncovered wood or metal cabinet.

Ah

Am

**UK-75 WALLACETON
20-1606 ELEV A
LOT 190D-26
THE GRASSFIELD**

25 of 35

**WHIRLPOOL 30" (76.0 CM) FREESTANDING ELECTRIC RANGES
Model YWFE515S0JS**

Install Anti-Tip Bracket

⚠ WARNING



Tip Over Hazard

A child or adult can tip the range and be killed.

Install anti-tip bracket to floor or wall per installation instructions.

Slide range back so rear range foot is engaged in the slot of the anti-tip bracket.

Re-engage anti-tip bracket if range is moved.

Do not operate range without anti-tip bracket installed and engaged.

Failure to follow these instructions can result in death or serious burns to children and adults.

1. Remove the anti-tip bracket from where it is taped inside the storage drawer or warming drawer.
2. Determine which mounting method to use: floor or wall. If you have a stone or masonry floor, you can use the wall mounting method. If you are installing the range in a mobile home, you must secure the range to the floor.
3. Determine and mark centerline of the cutout space. The mounting can be installed on either the left-side or right-side of the cutout. Position mounting bracket against the wall in the cutout so that the V-notch of the bracket is $12^{9}/_{16}$ " (31.9 cm) from centerline as shown.

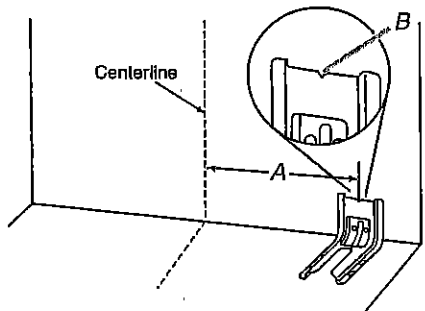

A. $12^{9}/_{16}$ " (31.9 cm)
B. Bracket V-notch

4. Drill two $1/8$ " (3 mm) holes that correspond to the bracket holes of the determined mounting method. See the following illustrations.

Floor Mounting

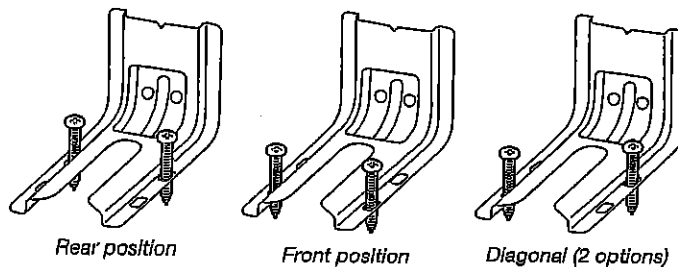

Wall Mounting

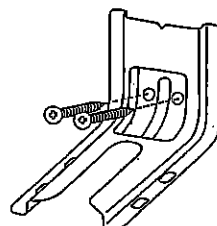

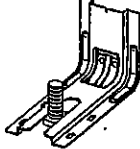
5. Using the Phillips screwdriver, mount anti-tip bracket to the wall or floor with the two #12 x $1^{5}/_{8}$ " (4.1 cm) screws provided.
 6. Move range close enough to opening to allow for final electrical connections. Remove shipping base, cardboard or hardboard from under range.
 7. Move range into its final location, making sure rear leveling leg slides into anti-tip bracket.
- 
8. Move range forward onto shipping base, cardboard or hardboard to continue installing the range using the following installation instructions.

Handwritten initials/signature



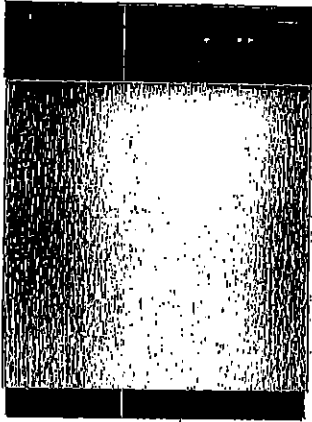
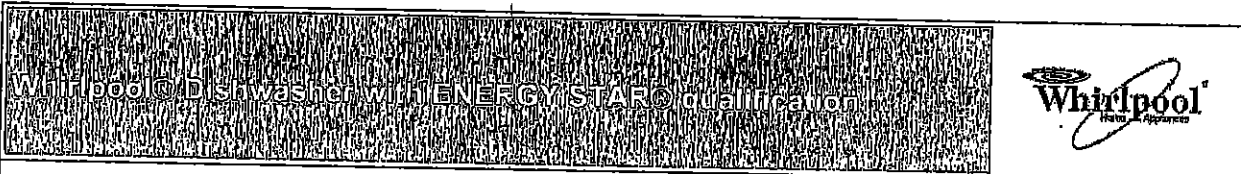

UK-75 WALLACETON
 20-1606 ELEV A
 LOT 190D-26
 THE GRASSFIELD

26 of 35



WDF310PAAS
Black-on-Stainless

OTHER AVAILABLE COLORS

-  Black
Model: WDF310PAAB
-  Black-on-Black
Model: WDF310PAAT
-  White
Model: WDF310PAAW
-  Universal Silver
Model: WDF310PAAD



DIMENSIONS		KEY FEATURES
Maximum Height	34 1/2 Inches	ENERGY STAR® Qualified No One Has Fewer Repairs 17 Years In A Row Resource - Efficient Wash System CEE Tier 1 qualified Tall Tub Design White Plastic Interior Quiet Partner(TM) I Sound Package Auto Soil Sensor Electronic Controls 3 Automatic Cycles 1-Hour Wash Cycle Heavy Wash Cycle Normal Cycle 4 Options High Temperature Wash System Heated Dry Option 4 Hour Delay Wash Option 4-Tier SheerClean Direct Feed Wash System Control Lock Vinyl Racks In-Rack Silverware Basket
Minimum Height	33 1/2 Inches	
Height	34 1/2 Inches	
Depth	24 1/2 Inches	
Width	23 7/8 Inches	
Dimensions shown are for planning purposes only. For complete information, see Installation Instructions packaged with product.		
ELECTRICAL		
15 Amps Amps, 60 Hz, 120 V, 15,		
Before purchasing this appliance, read important information about its estimated annual energy consumption or energy efficiency rating that is available from your dealer.		

A
AW

UK-75 WALLACETON
20-1606 ELEV A
LOT 190D-26
THE GRASSFIELD

27 of 35

Whirlpool® Undercounter Dishwasher

PRODUCT MODEL NUMBERS

WDF110PAB	WDF310PLA	WDF630PSY
WDF111PAB	WDF320PAD	WDF640PAD
WDF120PAF	WDF510PAY	WDF730PAY
WDF121PAF	WDF520PAD	WDT710PAY
WDF310PAA	WDF530PAY	WDT720PAD
WDF310PCA	WDF530PLY	WDT770PAY

Electrical Requirements: 120-volt, 60-Hz, AC only, 15- or 20-amp. fused electrical supply. Copper wire only. A time delay fuse or circuit breaker and separate circuit is recommended.

If direct wiring dishwasher: Use flexible, armored, or nonmetallic, sheathed copper wire with grounding wire that meets the wiring requirements for your home and local codes and ordinances. Use a UL listed or GSA approved conduit connector.

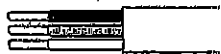

If connecting dishwasher with a power supply cord:

Use Power Supply Cord Kit (Part No. 4317824) marked for use with dishwashers. Follow the kit instructions for installing the power supply cord. Power supply cord must plug into a grounded 3 prong, outlet, located in the cabinet next to the dishwasher opening. Outlet must meet all local codes and ordinances.

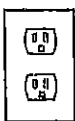

Water Supply Requirements: A hot water line with 20 to 120 psi (138 to 862 kPa) water pressure. Water temperature must be 120°F (49°C) water at dishwasher. Use 3/8" O.D. copper tubing with compression fitting or flexible braided water supply line (1/2" minimum plastic tubing is not recommended). Use a 90° elbow with 1/4" N.P.T. external pipe threads on one end. Do not solder within 6" (15.2 cm) from water inlet valve.

Drain Requirements: A new drain hose is supplied with your dishwasher. If this is not long enough, use a new drain hose with a maximum length of 12' (3.7 m) (Part No. 3385566) that meets all current AHAM/JAPMO test standards, is resistant to heat and detergent, and fits the 1" (2.5 cm) drain connector of the dishwasher.

Make sure to connect the drain hose to waste tee or disposer inlet above drain trap in house plumbing and 20" (50.8 cm) minimum above the floor. It is recommended that the drain hose either be looped up and securely fastened to the underside of the counter or be connected to an air gap.

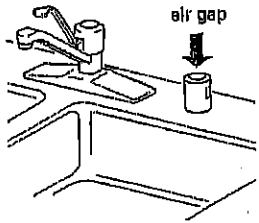

Make sure to use an air gap if the drain hose is connected to house plumbing lower than 20" (50.8 cm) above subfloor or floor.

Use 1/2" (1.3 cm) minimum I.D. drain line fittings.

If required, the air gap should be installed in accordance with the air gap installation instructions. When connecting the air gap, a rubber hose (not provided) will be needed to connect to the waste tee or disposer inlet.

PRODUCT DIMENSIONS

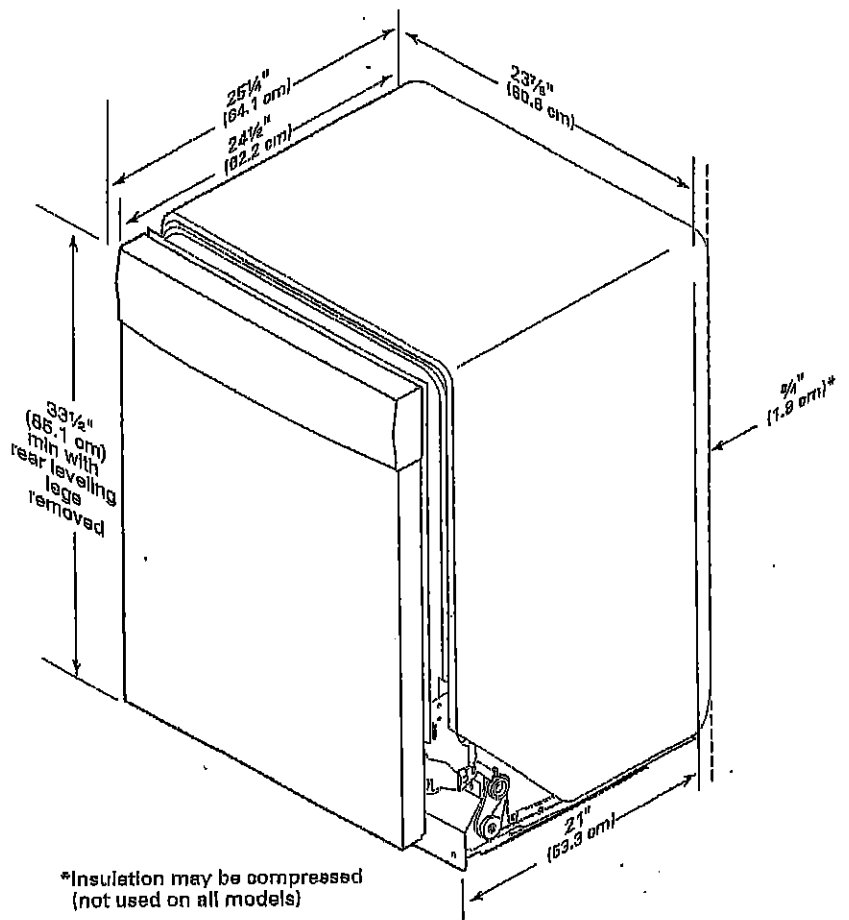

*Insulation may be compressed (not used on all models)

Because Whirlpool Corporation policy includes a continuous commitment to improve our products, we reserve the right to change materials and specifications without notice.

Dimensions are for planning purposes only. For complete details, see installation instructions packed with product. Specifications subject to change without notice.

Page 1 of 2
W10436040C-D-WH
5/1/18

Handwritten initials/signature

CABINET CUTOUT DIMENSIONS

WDF320PAB

NOTE: Shaded areas of cabinet walls show where utility connections may be installed.

*Measure from the lowest point on the underside of the countertop. May be reduced to 33½" (85.1 cm) by removing the rear leveling legs from dishwasher.

**Minimum, measured from narrowest point of opening.

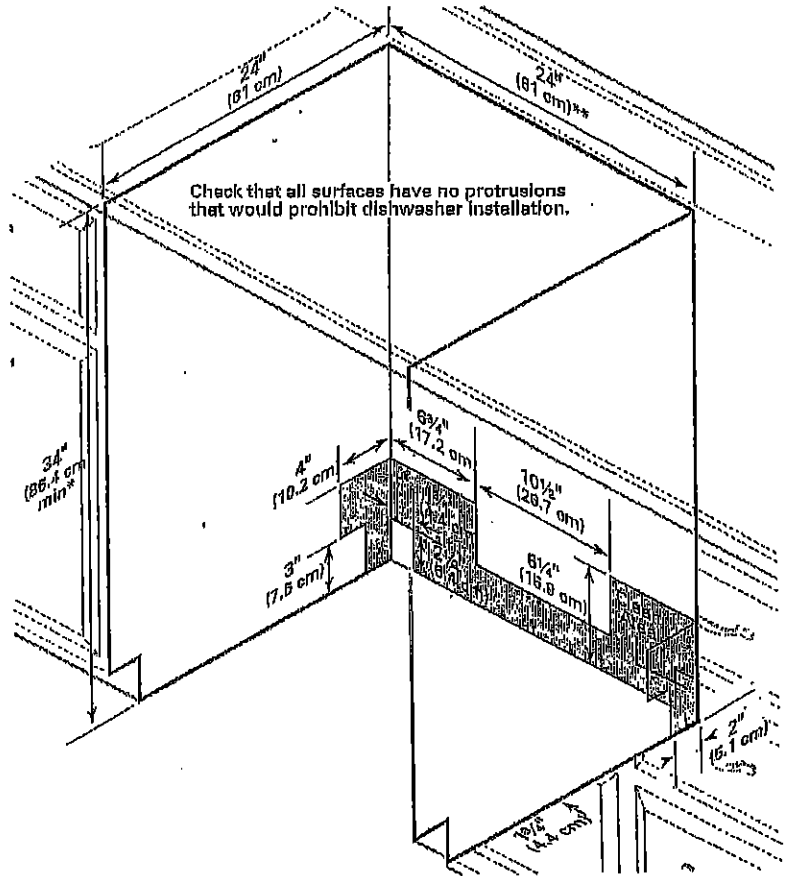

[Handwritten signature]

UK-75 WALLACETON
 20-1606 ELEV A
 LOT 190D-26
 THE GRASSFIELD

29 of 35

TO INCLUDE
 STACKING KIT PER PLAN

WHIRLPOOL WASHER Model #: WFW5620HW

Whirlpool Brand Canada English | Washers and Dryers | Washers | Front Load Washers | WFW5620HW

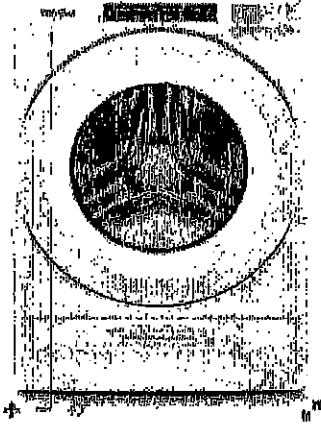

5.2 cu. ft. I.E.C. Closet-Depth
 Front Load Washer with
 Load & Go™ Dispenser



Whirlpool 5.2 cu. ft. I.E.C. Closet-Depth Front Load Washer with Load & Go™ Dispenser
 Model #: WFW5620HW

Dimensions

Depth	90.17 cm, 31-07/16 in
Depth With Door Open 90 Degree	149.51 cm, 59-1/2 in
Minimum Height	98.11 cm, 38-5/8 in
Width	68.58 cm, 27.0 in

Appearance

LCD Touch Screen	No
Window	Yes

Details

Drum Material	Stainless Steel
---------------	-----------------

Cycles and Options

Number of Wash Cycles	37
-----------------------	----

Electrical

Hz	60
Power Cord Included	Yes

AS
Alu

**UK-75 WALLACETON
20-1606 ELEV A
LOT 190D-26
THE GRASSFIELD**

30 of 35

WHIRLPOOL WASHER Model #: WFW5620HW

LOCATION REQUIREMENTS

Proper installation is your responsibility.

You will need:

- A water heater set to 120°F (49°C).
- A grounded electrical outlet located within 6 ft (1.8 m) of power cord on back of washer.
- Hot and cold water faucets located within 4 ft (1.2 m) of hot and cold water fill valves on washer, and water pressure of 20–100 psi (137.9–689.6 kPa).
- A level floor with maximum slope of 1" (25 mm) under entire washer. Installing on carpet or surfaces with foam backing is not recommended.
- Floor must support washer's total weight (with water and load) of 315 lbs (143 kgs).

IMPORTANT: Do not install, store, or operate washer where it will be exposed to weather or in temperatures below 32°F (0°C). Water remaining in washer after use may cause damage in low temperatures. See "Washer Care" in your Use and Care Guide for winterizing information.

Whirlpool Models*

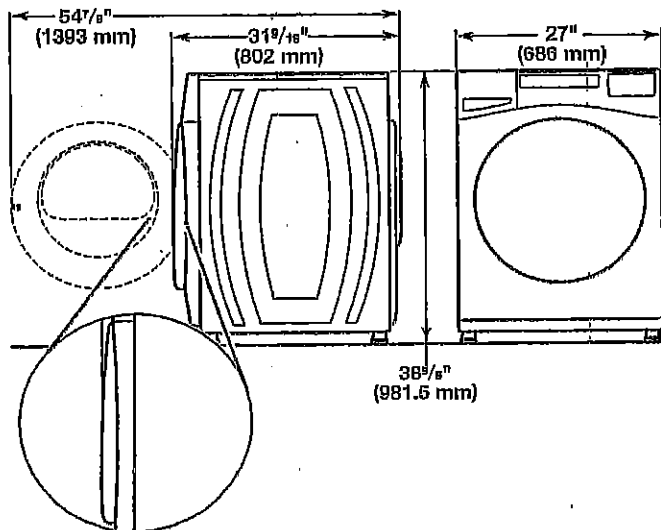
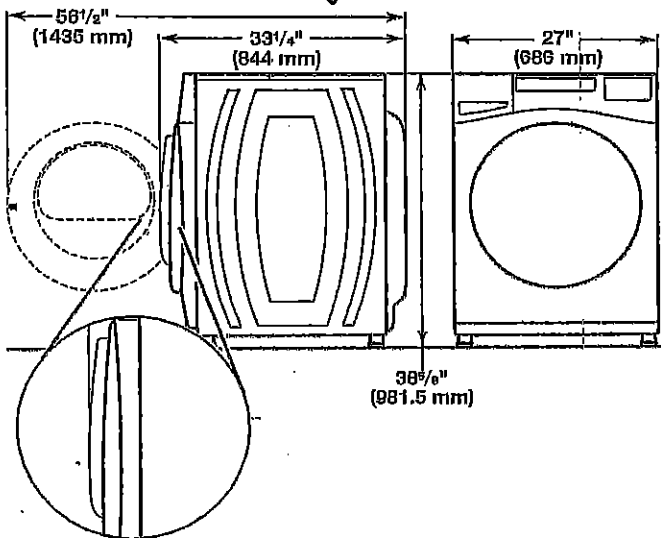

*For additional details (or information) specific to your model, refer to the 'Dimensions' listed for your model at www.whirlpool.com.

Maytag Models

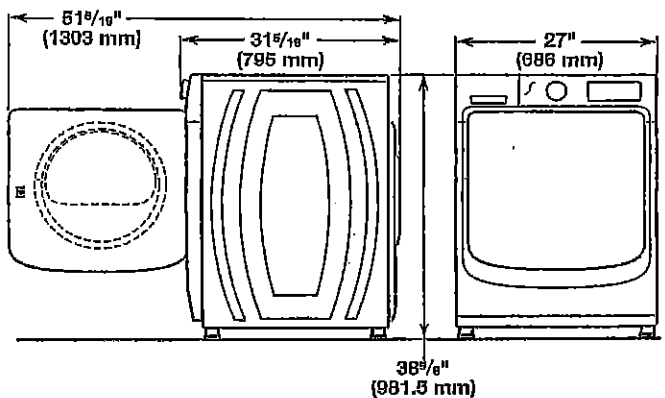
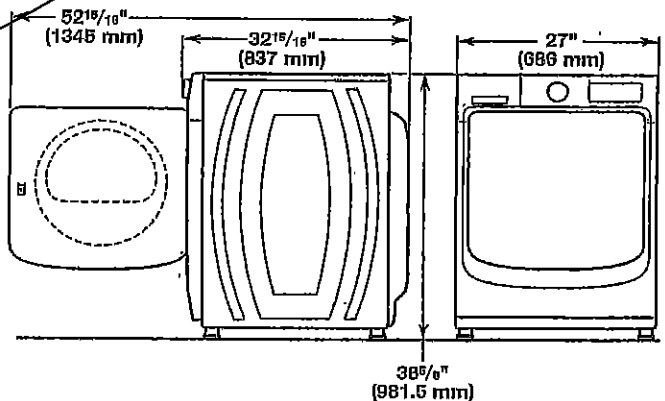

All dimensions show minimum spacing allowed. For each arrangement, consider allowing more space for ease of installation and servicing, and spacing for companion appliances and clearances for walls, doors, and floor moldings.

Space must be large enough to allow door to fully open. Add spacing of 1" (25 mm) on all sides of washer to reduce noise transfer. If a closet door or louvered door is installed, top and bottom air openings in door are required.

Recessed area or closet installation (stacked washer and dryer):

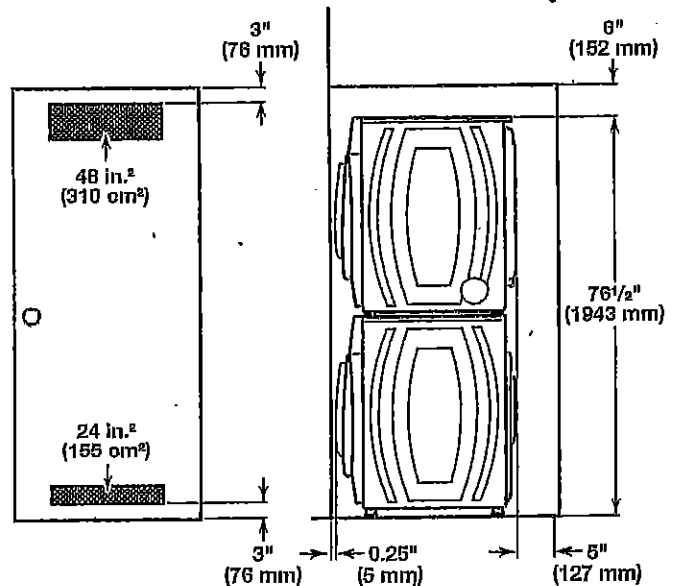

Handwritten signature

WHIRLPOOL WASHER Model #: WFW5620HW

Custom under-counter installation:

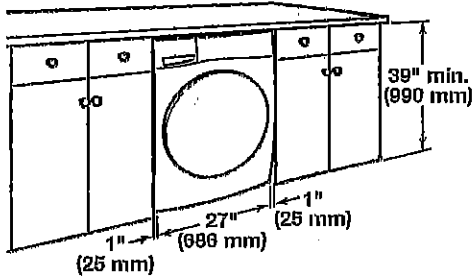

DRAIN SYSTEM

The drain system can be installed using a floor drain, wall standpipe, floor standpipe, or laundry tub. Select the method you need.

IMPORTANT: To avoid siphoning, only 4.5" (114 mm) of drain hose should be inside standpipe. Always secure drain hose with cable tie.

Floor standpipe drain system

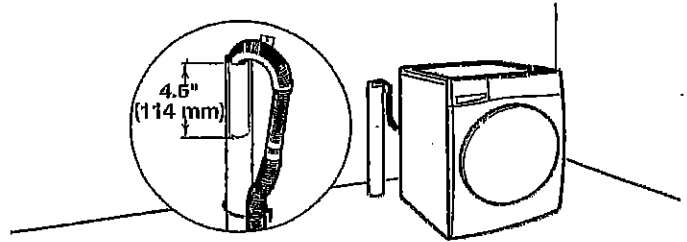

Minimum diameter for a standpipe drain: 2" (51 mm). Minimum carry-away capacity: 17 gal. (64 L) per minute. A 1/4" (6 mm) diameter to 1" (25 mm) diameter Standpipe Adapter Kit is available (Part Number 3383920). Top of standpipe must be at least 30" (762 mm) high; install no higher than 96" (2.44 m) from bottom of washer. If you have an overhead sewer and need to pump higher than 96" (2.44 m), a sump pump and associated hardware are needed. See "Alternate parts."

Wall standpipe drain system

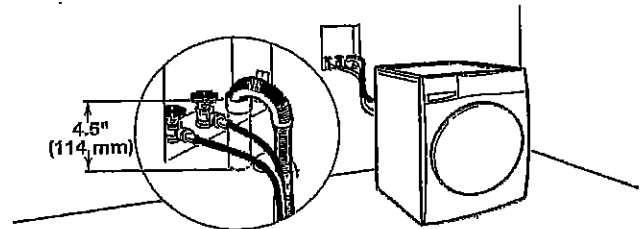

See requirements for floor standpipe drain system.

Laundry tub drain system

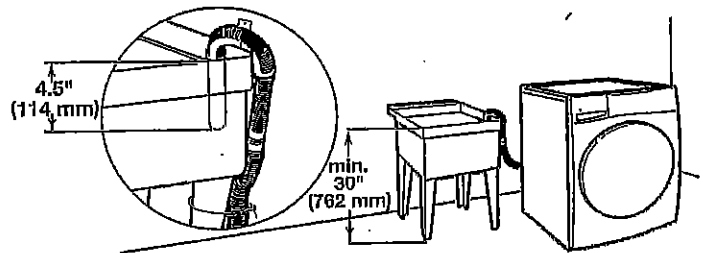

Minimum capacity: 20 gal. (76 L). Top of laundry tub must be at least 30" (762 mm) above floor; install no higher than 96" (2.44 m) from bottom of washer.

Recessed area or closet installation:

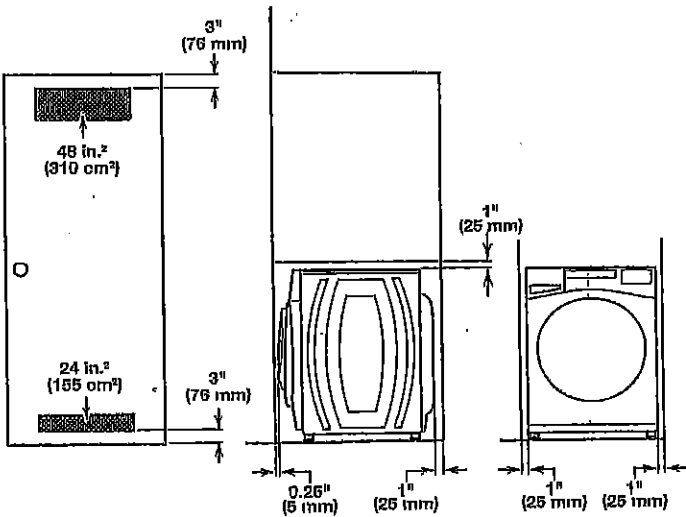

Custom cabinet installation:

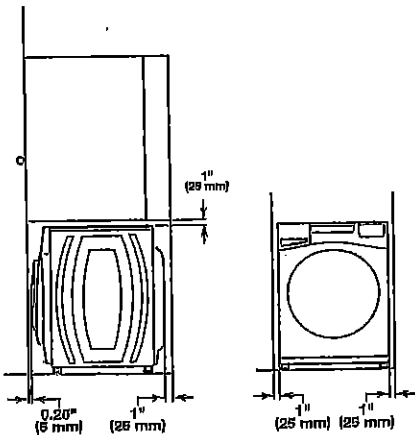

Handwritten initials/signature

UK-75 WALLACETON
20-1606 ELEV A
LOT 190D-26
THE GRASSFIELD

32 of 35

WHIRLPOOL DRYER Model #: YWED5620HW

Whirlpool Brand Canada English | Washer and Dryer | Dryer | Electric Dryer | YWED5620HW

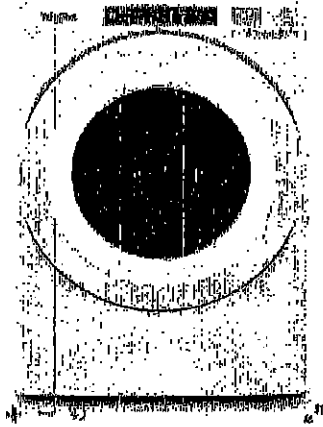

7.4 cu. ft. Front Load Electric Dryer with Intuitive Touch Controls



Whirlpool 7.4 cu. ft. Front Load Electric Dryer with Intuitive Touch Controls

Model #: YWED5620HW

Dimensions

Depth	78.74 cm, 31.0 in
Depth With Door Open 90 Degree	198.43 cm, 64-1/2 in
Height	98.42 cm, 38-9/16 in
Width	68.58 cm, 27.0 in

Configuration and Overview

Fuel Type	Electric
-----------	----------

Cycles and Options

Cycle Time Remaining	Yes
Lint Filter Indicator	No
Number of Dryer Cycles	36
Number of Dryness Levels	3

Ventilation System

Long Vent	No
Maximum Vent Length	64
Venting Direction	Left, Right, Bottom, Rear

Electrical

Hz	60
Power Cord Included	Yes

As All

**UK-75 WALLACETON
20-1606 ELEV A
LOT 190D-26
THE GRASSFIELD**

33 of 35

WHIRLPOOL DRYER Model #: YWED5620HW

Back view:

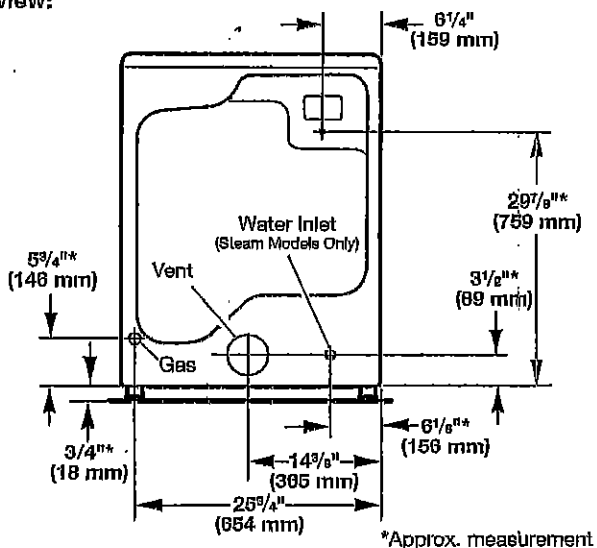

NOTE: Most installations require a minimum of 5" (127 mm) clearance behind dryer for exhaust vent with elbow. See "Venting Requirements."

Installation Clearances

For each arrangement, consider allowing more space for ease of installation and servicing, spacing for companion appliances, and clearances for walls, doors, and floor moldings. Space must be large enough to allow door to fully open. Add spacing on all sides of dryer to reduce noise transfer. If a closet door or louvered door is installed, top and bottom air openings in door are required.

Check code requirements. Some codes limit, or do not permit, installation of the dryer in garages, closets, mobile homes, or sleeping quarters. Contact your local building inspector.

NOTE: No other fuel-burning appliance can be installed in the same closet as a dryer.

Installation spacing for recessed area or closet installation

All dimensions show recommended and minimum spacing allowed.

- Additional spacing should be considered for ease of installation and servicing.
- Additional clearances might be required for wall, door, floor moldings, dryer venting, and gas line.
- Additional spacing should be considered on all sides of the dryer to reduce noise transfer.
- For closet installation with a door, minimum ventilation openings in the top and bottom of the door are required. Louvered doors with equivalent ventilation openings are acceptable.
- Companion appliance spacing should also be considered.

Recommended installation clearances (dryer only):

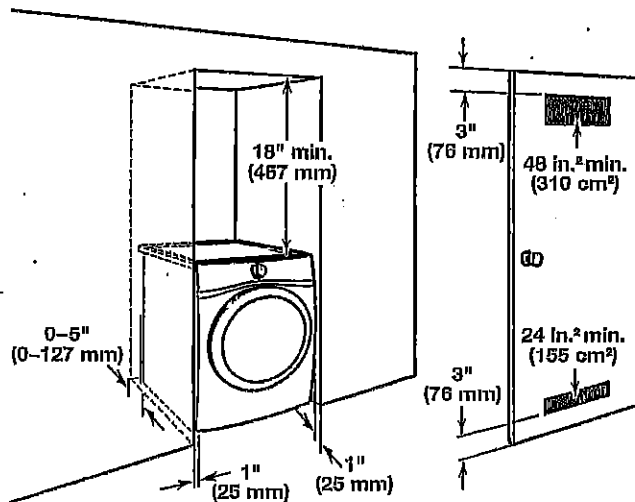

0" (0 mm) rear spacing is allowed for straight back venting only. For steam models only, inlet hose must not be kinked.

Custom under-counter installation:

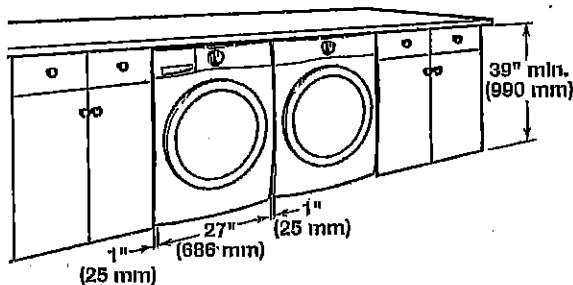

Mobile home - Additional installation requirements:

This dryer is suitable for mobile home installations. The installation must conform to the Manufactured Home Construction and Safety Standard, Title 24 CFR, Part 3280 (formerly the Federal Standard for Mobile home construction and Safety, Title 24, HUD Part 280) or Standard CAN/CSA-Z240 MH.

Mobile home installations require:

- Metal exhaust system hardware, available for purchase from your dealer. For further information, see "Assistance or Service" in your Use and Care Guide.
- Special provisions must be made in mobile homes to introduce outside air into dryer. Openings (such as a nearby window) should be at least twice as large as dryer exhaust opening.

For mobile home installation of gas dryers:

- Mobile Home Installation Hold-down Kit Part Number 346764 is available to order. For further information, see "Assistance or Service" in your Use and Care Guide.

Handwritten signatures

**UK-75 WALLACETON
20-1606 ELEV A
LOT 190D-26
THE GRASSFIELD**

34 of 35

WHIRLPOOL DRYER Model #: YWED5620HW

Additional parts may be required, depending on your installation. Check local codes. Check existing electrical supply and venting. Read "Electrical Requirements" and "Venting Requirements" before purchasing parts.

If using a power supply cord:

Use a UL Listed power supply cord kit marked for use with clothes dryers. The kit should contain:

- A UL Listed 30 amp power supply cord, rated 120/240 volt minimum. The cord should be type SRD or SRDT and be at least 4 ft. (1.22 m) long. The wires that connect to the dryer must end in ring terminals or spade terminals with upturned ends.
- A UL Listed strain relief.

Optional Equipment (not supplied with dryer):

Refer to your Use and Care Guide for information about accessories available for your dryer.

LOCATION REQUIREMENTS

Check code requirements. Some codes limit, or do not permit, installing dryer in garages, closets, mobile homes, or sleeping quarters. Contact your local building inspector.

DRYER DIMENSIONS

Front view:

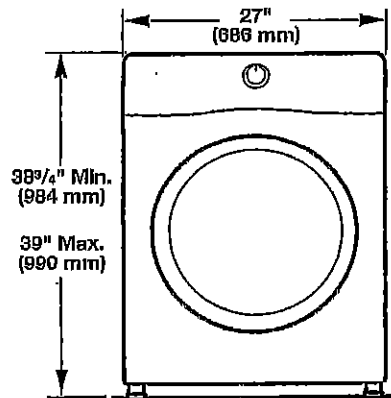

Side view:

Whirlpool Models

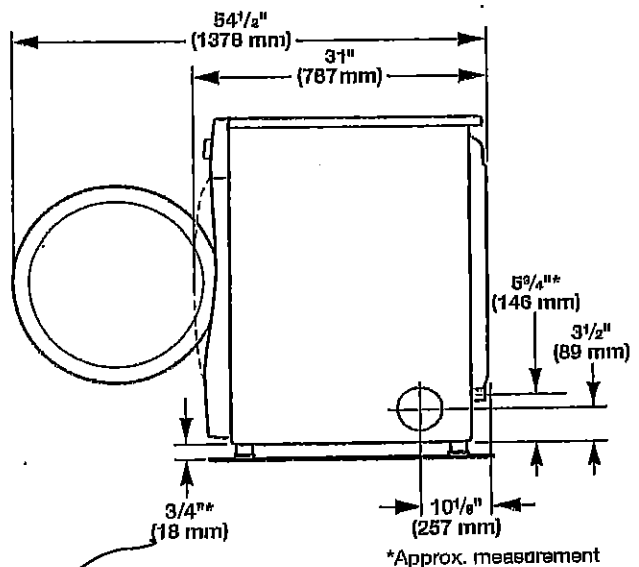

Maytag Models

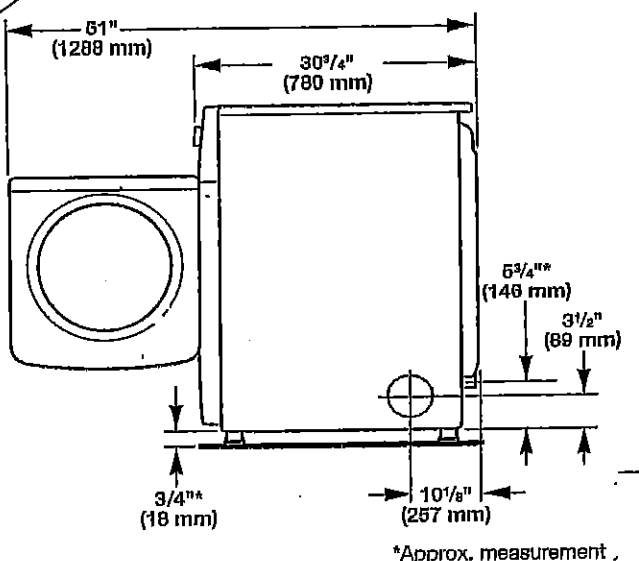

⚠ WARNING

Explosion Hazard

Keep flammable materials and vapors, such as gasoline, away from dryer.

Place dryer at least 18 inches (460 mm) above the floor for a garage installation.

Failure to do so can result in death, explosion, or fire.

You will need:

- A location allowing for proper exhaust installation. See "Venting Requirements."
- A separate 15 or 20 amp circuit for a gas dryer or 30 amp circuit for an electric dryer.
- If using power supply cord, a grounded electrical outlet located within 2 ft. (610 mm) of either side of dryer. See "Electrical Requirements."
- Floor must support dryer weight of 200 lbs. (90.7 kg). Also consider weight of companion appliance.
- Cold water faucets located within 4 ft. (1.2 m) of the water fill valves, and water pressure of 20-120 psi (138-827 kPa). You may use your washer's water supply by purchasing the necessary parts noted in "Parts needed."
- Level floor with maximum slope of 1" (25 mm) under entire dryer. If slope is greater than 1" (25 mm), install Extended Dryer Feet Kit, Part Number 279810. If not level, clothes may not tumble properly and automatic sensor cycles may not operate correctly.
- For garage installation, place dryer at least 18" (460 mm) above floor. If using a pedestal, you will need 18" (460 mm) to bottom of dryer.
- The dryer must not be installed or stored in an area where it will be exposed to water and/or weather.

IMPORTANT: Do not operate, install, or store dryer where it will be exposed to water, weather, or at temperatures below 40°F (4°C). Lower temperatures may cause dryer not to shut off at end of automatic sensor cycles, resulting in longer drying times.

Handwritten signature

UK 75- WALLACETON
 20-1606 ELEV. A
 THE GRASSFIELD
 LOT 190D-26

35 of 35

WHIRLPOOL DRYER Model #: YWED5620HW

Additional parts may be required, depending on your installation. Check local codes. Check existing electrical supply and venting. Read "Electrical Requirements" and "Venting Requirements" before purchasing parts.

If using a power supply cord:

Use a UL Listed power supply cord kit marked for use with clothes dryers. The kit should contain:

- A UL Listed 30 amp power supply cord, rated 120/240 volt minimum. The cord should be type SRD or SRDT and be at least 4 ft. (1.22 m) long. The wires that connect to the dryer must end in ring terminals or spade terminals with upturned ends.
- A UL Listed strain relief.

Optional Equipment (not supplied with dryer):

Refer to your Use and Care Guide for information about accessories available for your dryer.

LOCATION REQUIREMENTS

Check code requirements. Some codes limit, or do not permit, installing dryer in garages, closets, mobile homes, or sleeping quarters. Contact your local building inspector.

⚠ WARNING



Explosion Hazard

Keep flammable materials and vapors, such as gasoline, away from dryer.

Place dryer at least 18 inches (460 mm) above the floor for a garage installation.

Failure to do so can result in death, explosion, or fire.

You will need:

- A location allowing for proper exhaust installation. See "Venting Requirements."
- A separate 15 or 20 amp circuit for a gas dryer or 30 amp circuit for an electric dryer.
- If using power supply cord, a grounded electrical outlet located within 2 ft. (610 mm) of either side of dryer. See "Electrical Requirements."
- Floor must support dryer weight of 200 lbs. (90.7 kg). Also consider weight of companion appliance.
- Cold water faucets located within 4 ft. (1.2 m) of the water fill valves, and water pressure of 20-120 psi (138-827 kPa). You may use your washer's water supply by purchasing the necessary parts noted in "Parts needed."
- Level floor with maximum slope of 1" (25 mm) under entire dryer. If slope is greater than 1" (25 mm), install Extended Dryer Feet Kit, Part Number 279810. If not level, clothes may not tumble properly and automatic sensor cycles may not operate correctly.
- For garage installation, place dryer at least 18" (460 mm) above floor. If using a pedestal, you will need 18" (460 mm) to bottom of dryer.
- The dryer must not be installed or stored in an area where it will be exposed to water and/or weather.

IMPORTANT: Do not operate, install, or store dryer where it will be exposed to water, weather, or at temperatures below 40°F (4°C). Lower temperatures may cause dryer not to shut off at end of automatic sensor cycles, resulting in longer drying times.

DRYER DIMENSIONS

Front view:

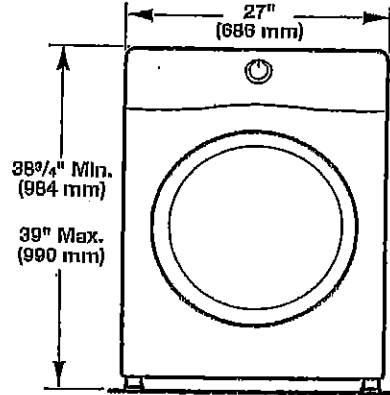

Side view:

Whirlpool Models

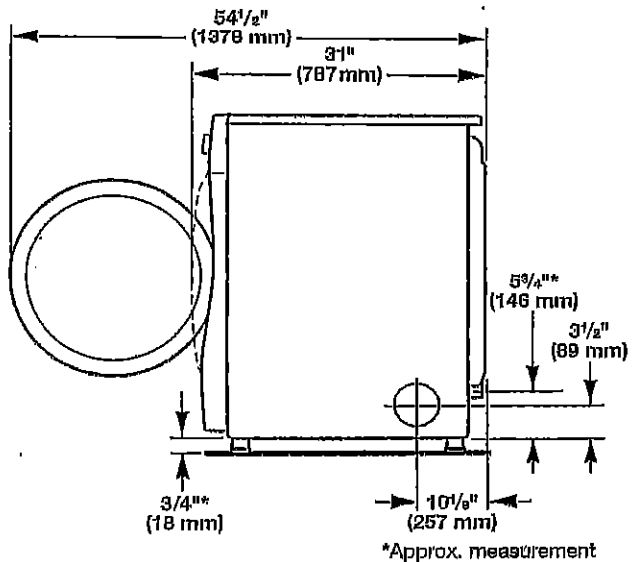

Maytag Models

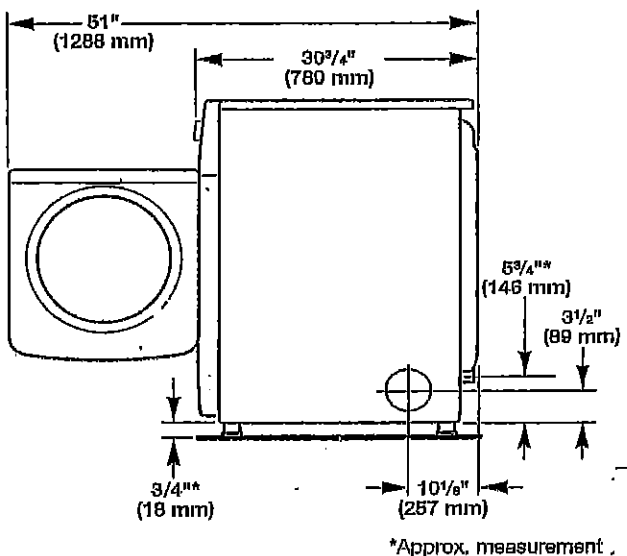

Handwritten signature