

10 Revision

CONSTRUCTION SUMMARY

Mountainview Heights 3 (G) - Russell Gardens Building Ltd.

PURCHASERS: James Daniel CARREIRO and Tonya Lee AMORUSO

Appliance
TEL: RES.: 289-259-8270

LOT / PHASE	REG. PLAN #	HOUSE TYPE	
395 / 4	62M-1266	Valleycreek Three Elev 1	Spec's

CABINETS

1 - CABINETS - KITCHEN - LIGHT VALENCE - NO ELECTRICAL 29Oct21 Note:	
1 - DELETE HARDWARE NO HOLES DRILLED - KITCHEN 29Oct21 Note:	
1 - KITCHEN CABINETS - DIFFERENT COLOUR ISLAND - FLAT FEE 29Oct21 Note:	
1 - CABINETS - KITCHEN - UPGRADE 3 29Oct21 Note:	
1 - VANITY - ENSUITE - UPGRADE 3 29Oct21 Note:	
1 - CABINETS PROVISION - PROVISION FOR PLUG ON ISLAND (PLUG EXTRA ORDERED SEPARATELY) 29Oct21 Note:	

Attached

CABINETS ACCESSORIES

2 - KITCHEN CABINETS BASE - DUMMY DOOR FOR BASE CABINETS - UPGRADE 3 29Oct21 Note:	
1 - KITCHEN - ISLAND - CREATE OPENING FOR WINE FRIDGE ON ISLAND 29Oct21 Note:	
1 - KITCHEN HOOD CABINETS - CONTEMPORARY WOOD HOOD - UPGRADE 3 29Oct21 Note: PURCHASER TO SUPPLY AND INSTALL FAN AFTER CLOSING - 6" Vent Supplied By Builder:	
1 - PANTRY UNIT UPGRADE - TO GO FROM 300MM TO 600MM DEEP - PRICE IS PER FOOT - UPGRADE 3 29Oct21 Note:	
1 - KITCHEN CABINETS UPPER - FULL DEPTH ABOVE FRIDGE - WITH GABLES - 600MM - PRICE IS EACH - UPGRADE 3 29Oct21 Note:	
1 - KITCHEN CABINETS UPPER - MICROWAVE SHELF STANDARD - 700MM WIDE - UPGRADE 3 29Oct21 Note:	
1 - KITCHEN CABINETS BASE - PULLOUT RECYCLE 4 BIN - PRICE IS EACH 29Oct21 Note:	
2 - KITCHEN CABINETS BASE - POT/PAN DRAWERS (CABINET) - UPGRADE 3 29Oct21 Note:	
1 - KITCHEN CABINETS BASE - PULLOUT WIRE SPICE RACK - PRICE IS EACH 29Oct21 Note:	

CERAMIC TILE

1 - TILE - UPGRADE 2 FLOOR TILE - - LAUNDRY ROOM 29Oct21 Note:	
1 - TILE - UPGRADE 2 FLOOR TILE - - POWDER ROOM 29Oct21 Note:	
1 - GROUT COLOUR - UPGRADE GROUT COLOUR THROUGHOUT - FLAT FEE 29Oct21 Note:	
1 - TILE - UPGRADE 4 WALL TILE - - ENSUITE WALL TILE - SHOWER 29Oct21 Note:	
1 - TILE - UPGRADE 4 FLOOR TILE - - ENSUITE BATHROOM - FLOOR 29Oct21 Note:	

CONSTRUCTION SUMMARY

Mountainview Heights 3 (G) - Russell Gardens Building Ltd.

PURCHASERS: James Daniel CARREIRO and Tonya Lee AMORUSO

TEL: RES.: 289-259-8270

LOT / PHASE	REG. PLAN #	HOUSE TYPE		
395 / 4	62M-1266	Valleycreek Three Elev 1		

1 - PRICE IS FOR LABOUR ONLY - INSTALL TILE IN A STAGGERED PATTERN - - BATHROOM 2/3 - TUB AREA
29Oct21 Note:

1 - PRICE IS FOR LABOUR ONLY - INSTALL TILE IN A STAGGERED PATTERN - - BATHROOM 4 - SHOWER
29Oct21 Note:

1 - TILE - UPGRADE 1 FLOOR TILE - - BATHROOM 2/3 - FLOOR
29Oct21 Note:

1 - TILE - UPGRADE 1 FLOOR TILE - - BATHROOM 4 - FLOOR
29Oct21 Note:

1 - DELETE ALL CERAMIC BATHROOM ACCESSORIES - DELETE TOWEL BAR, PAPER HOLDER & SOAP DISH THROUGHOUT
29Oct21 Note:

CONSTRUCTION

1 - SMOOTH CEILINGS ON FIRST FLOOR ONLY - DET
29Oct21 Note:

3 - ENLARGE BASEMENT WINDOWS (MAY REQUIRE WINDOW WELLS) - WINDOW IS 30 INCHES X 24 INCHES
20May21 Note:

COUNTER TOP

1 - COUNTER TOP - UPGRADE TO CAESARSTONE - KITCHEN COUNTER TOP - IN LIEU OF STANDARD GRANITE AS PER OFFER
29Oct21 Note:

DOORS AND TRIM

1 - TRIM - UPGRADE 1- 5-1/4" ONE STEP BASEBOARD AND ONE STEP CASING
29Oct21 Note:

ELECTRICAL

1 - PLUG - ELECTRICAL PLUG - FOR WINE FRIDGE
29Oct21 Note:

1 - PLUG - ELECTRICAL PLUG - FOR MICROWAVE SHELF
29Oct21 Note:

1 - PLUG - ELECTRICAL PLUG WITH GFI AND SWITCH - FOR FESTIVE LIGHTING
29Oct21 Note:

1 - PLUG - ELECTRICAL PLUG - TO BE INSTALLED OVER FIREPLACE
29Oct21 Note:

1 - PLUG - ELECTRICAL PLUG - ADD TO ISLAND
29Oct21 Note:

1 - RELOCATE STANDARD KITCHEN LIGHT TO BE CENTERED OVER ISLAND
29Oct21 Note:

1 - POWDER ROOM - INSTALL STANDARD LIGHT ON WALL ABOVE MIRROR - IF CONSTRUCTION PERMITS
29Oct21 Note:

1 - 200 AMP ELECTRICAL SERVICE
20May21 Note:

FIREPLACE AND ACCESSORIES

1 - GAS LINE ROUGH-IN FOR STOVE (INCLUDES ELECTRICAL OUTLET) - FIRST FLOOR
29Oct21 Note:

HARDWOOD FLOORING

CONSTRUCTION SUMMARY

Mountainview Heights 3 (G) - Russell Gardens Building Ltd.

PURCHASERS: James Daniel CARREIRO and Tonya Lee AMORUSO

TEL: RES.: 289-259-8270

LOT / PHASE	REG. PLAN #	HOUSE TYPE		
395 / 4	62M-1266	Valleycreek Three Elev 1		

1 - HARDWOOD - GROUP B SERIES 5 INCH - IN LIEU OF 2 1/4 INCH NATURAL RED OAK - - FAMILY ROOM
29Oct21 Note:

1 - HARDWOOD - GROUP B SERIES 5 INCH - IN LIEU OF 2 1/4 INCH NATURAL RED OAK - - DINING ROOM
29Oct21 Note:

1 - HARDWOOD - GROUP B SERIES 5 INCH - IN LIEU OF STANDARD TILE - KITCHEN/BREAKFAST
29Oct21 Note:

1 - HARDWOOD - GROUP B SERIES 5 INCH - IN LIEU OF STANDARD TILES - FOYER & LOWER LANDING
29Oct21 Note:

MIRRORS AND GLASS

1 - SHOWER DOOR HANDLE - CHROME D-RING WITH TOWEL BAR - MASTER ENSUITE BATHROOM
29Oct21 Note:

1 - ALL BATHROOMS - DELETE STANDARD MIRRORS - DO NOT INSTALL
29Oct21 Note:

1 - MASTER ENSUITE - FRAMELESS GLASS SHOWER ENCLOSURE - INCLUDES CHROME KNOB AND HINGES
20May21 Note:

PLUMBING

1 - SINK - UNDERMOUNT SINK - BLANCO QUATRUS R15 U SUPER SINGLE #401518 - KITCHEN
02Nov21 Note:

PROMOTIONAL

1 - LESS BALANCE OF CREDIT FROM PURCHASER EXTRA SHEET IN OFFER
29Oct21 Note:

1 - LESS CREDIT FROM PURCHASER EXTRA SHEET IN OFFER
20May21 Note: NEW PROMO BALANCE \$2940.00

STAIRS AND RAILINGS

1 - STAINED STAIRS - STANDARD STAIRCASE - PRICE IS PER SET
29Oct21 Note:

1 - STAIRCASE - V GROOVE HANDRAIL
29Oct21 Note:

1 - STAIRCASE - EUROLINE 0 IRON PICKETS - BLACK
29Oct21 Note:

EXTRAS AS PER OFFER

PURCHASER(S) ACKNOWLEDGES THAT THE PURCHASE PRICE IS INCLUSIVE OF ALL CREDITS AND PROMOTIONAL PACKAGES AVAILABLE AT TIME OF PURCHASE.
Worksheet Note:

(1) The Vendor agrees that notwithstanding any other term or provision in this Agreement included in the Purchase Price and in addition to those items detailed in Schedule GP to the Agreement of Purchase and Sale, the Purchaser is entitled to a credit of
Worksheet Note:

Granite kitchen counter top, from Vendor's standard samples
Worksheet Note:

FILE NAME:
 RUSSELL GARDENS LOT 395 PH 4

RUSSELL GARDENS LOT 395 PH 4
 PROTOTYPE FOR EXTRAS

NOV 19 21 FB

THIS LAYOUT CONTAINS EXTRAS
 THAT ARE NOT PART OF CONTRACT

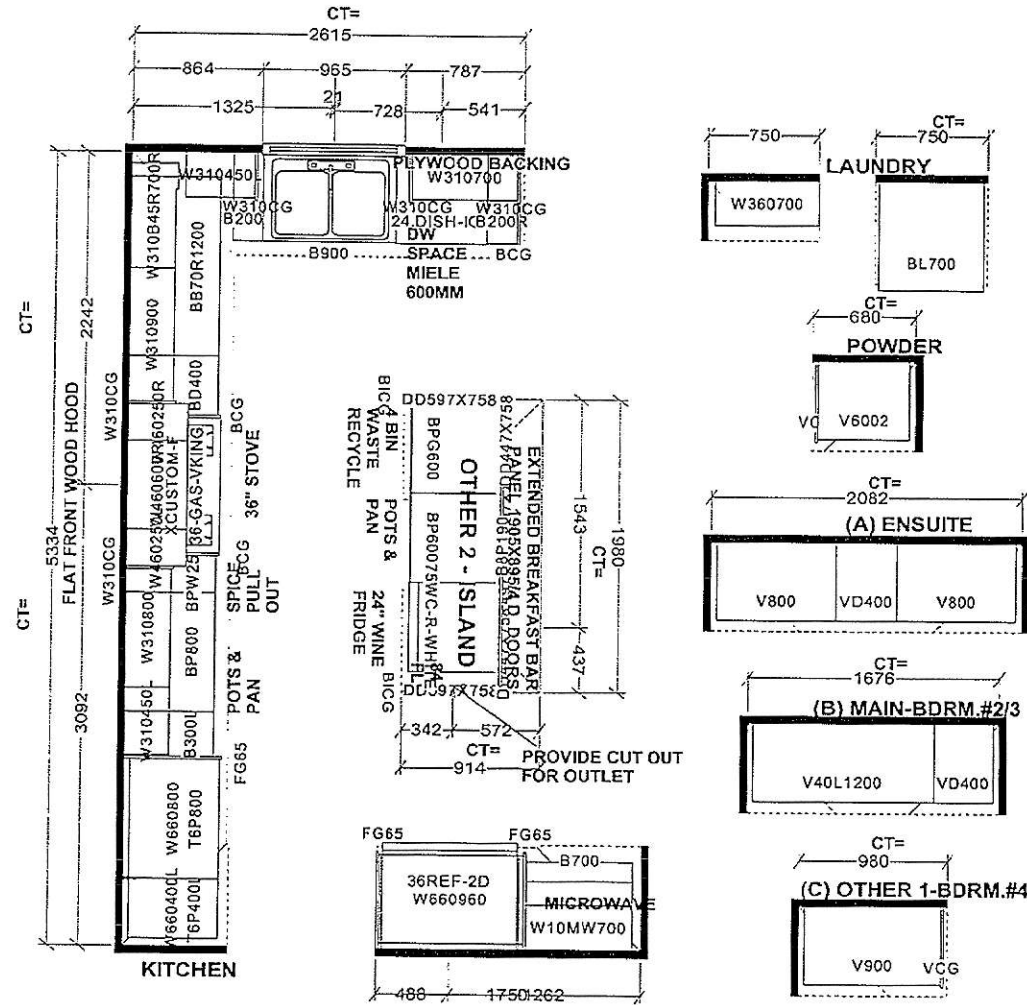

Selba Industries			J#
WW DTH _____	W HGHT _____	WCNT _____	JOB NUMBER: BUILDER: GREENPARK SITE: RUSSELL GARDENS PH.3 MODEL: VALLEYCREEK 3X EL 1,2,3 LOT #: 395
FLOOR HGHT _____	DOOR HGHT _____	ST CENT _____ 2X4 _____	
VENT BOX COVER _____			
This drawing is the intellectual property of SELBA INDUSTRIES INC. and is an original design which must not be released or copied unless applicable fee has been paid in full.			
DATE: MAY 13 20			DESIGNER: KS DATE: MAY 13 20

RUSSELL GARDENS PH4
LOT 395

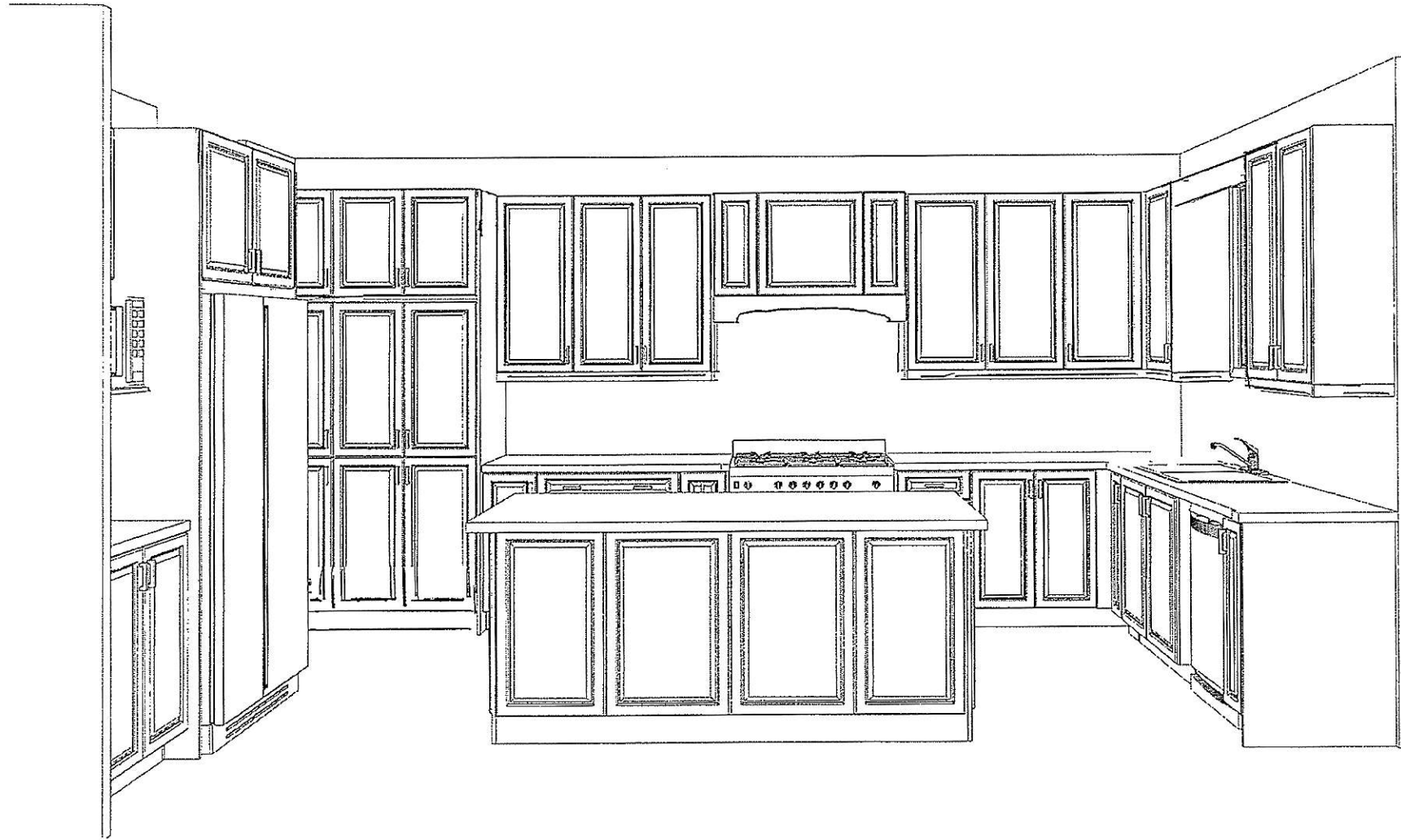

RUSSELL GARDENS PH4
LOT 395

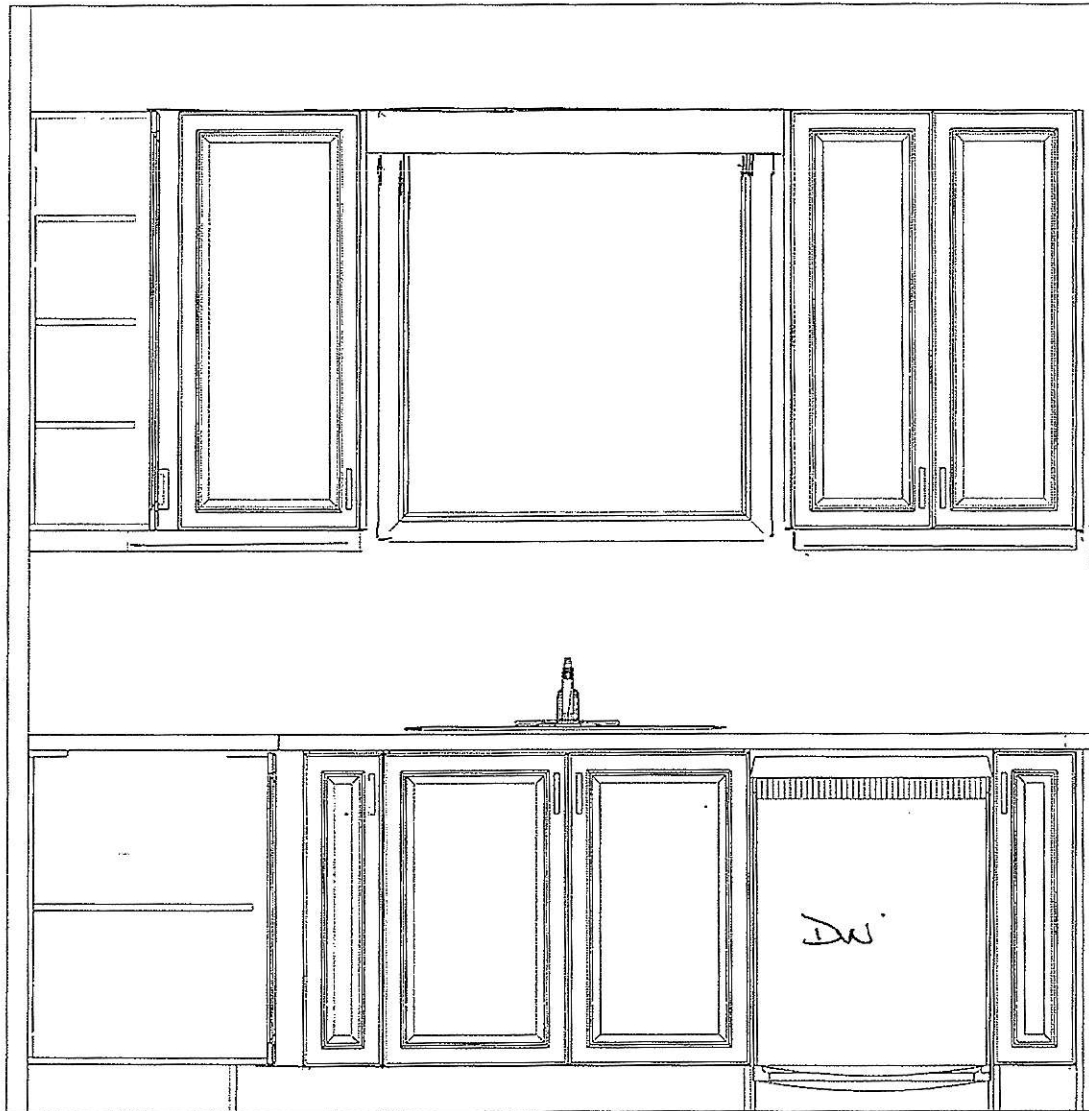

RUSSELL GARDENS PH 4
LOT 395

FLAT FRONT WOOD HOOD

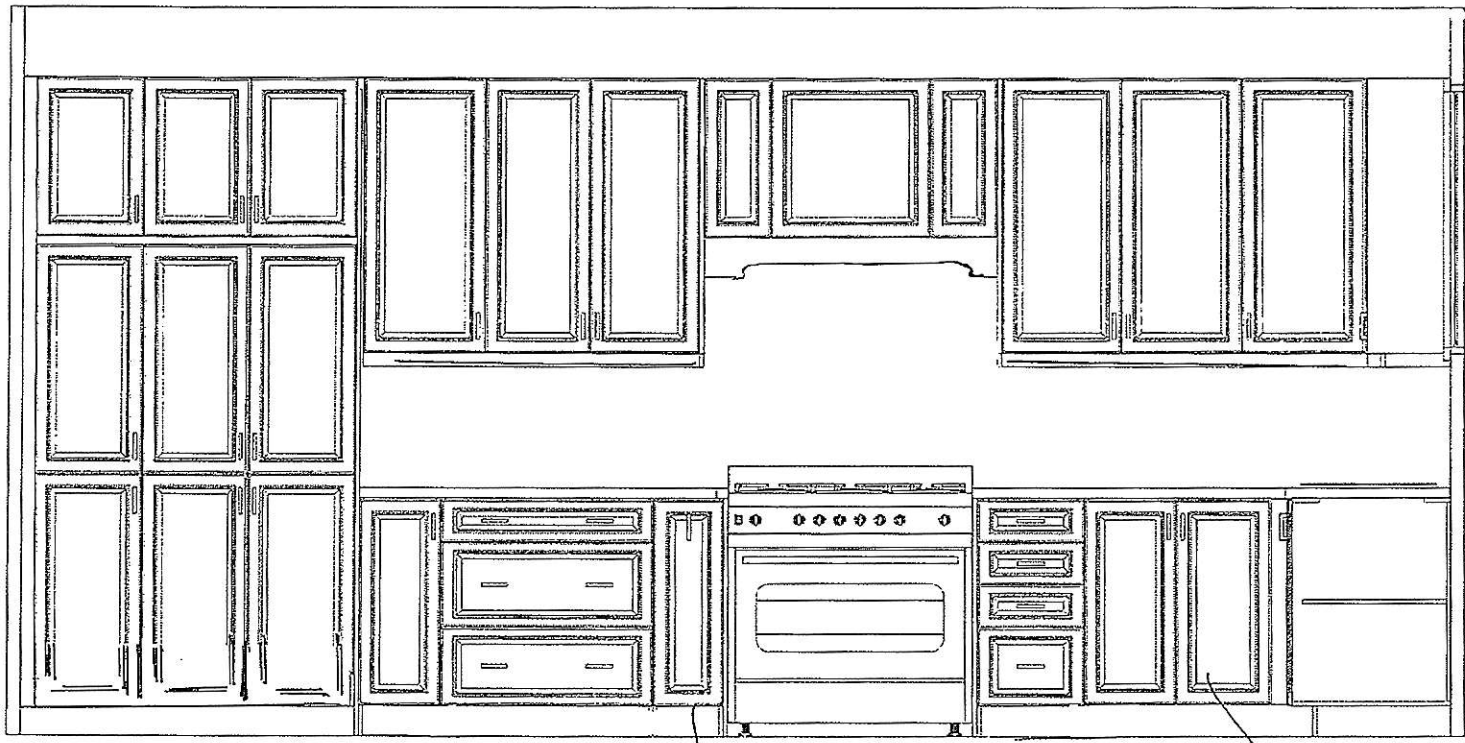

PANTRY
24" DEEP

SPICE
PULL
OUT

36"
STOVE

BLIND CORNER
BASE

RUSSELL GARDENS PH4
LOT 395

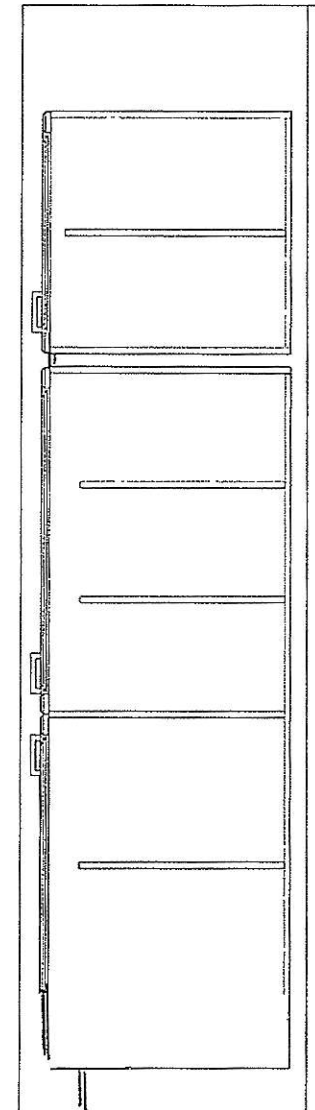
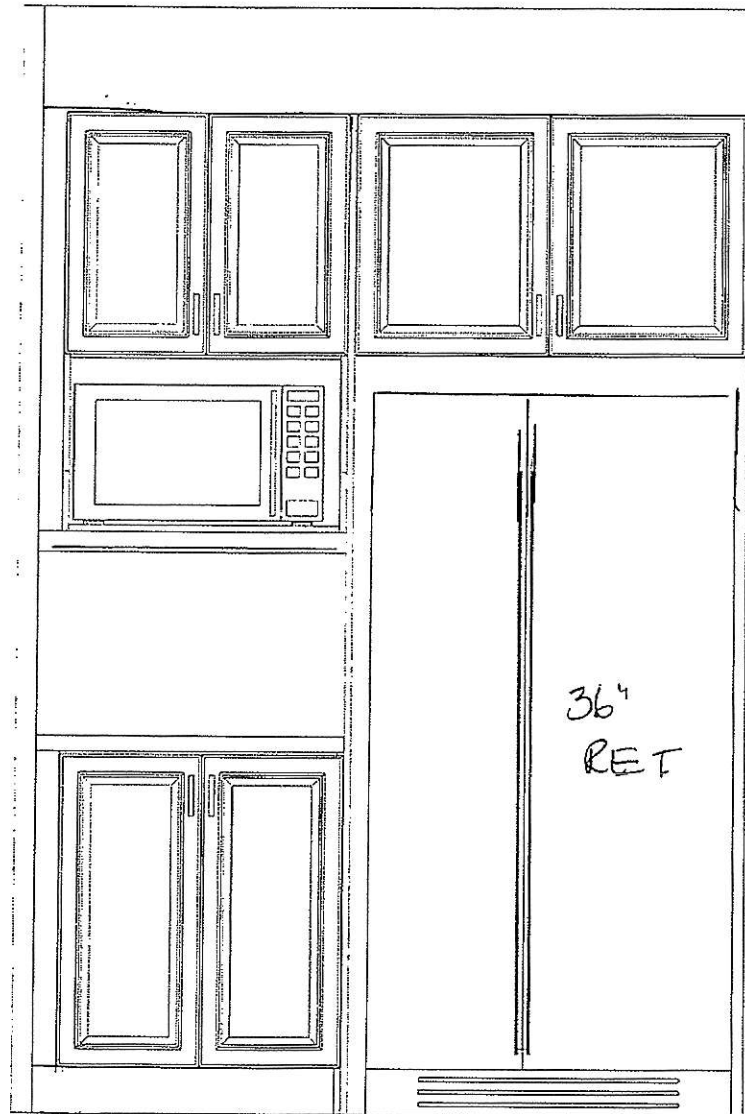

RUSSELL GARDENS PH4
LOT 395

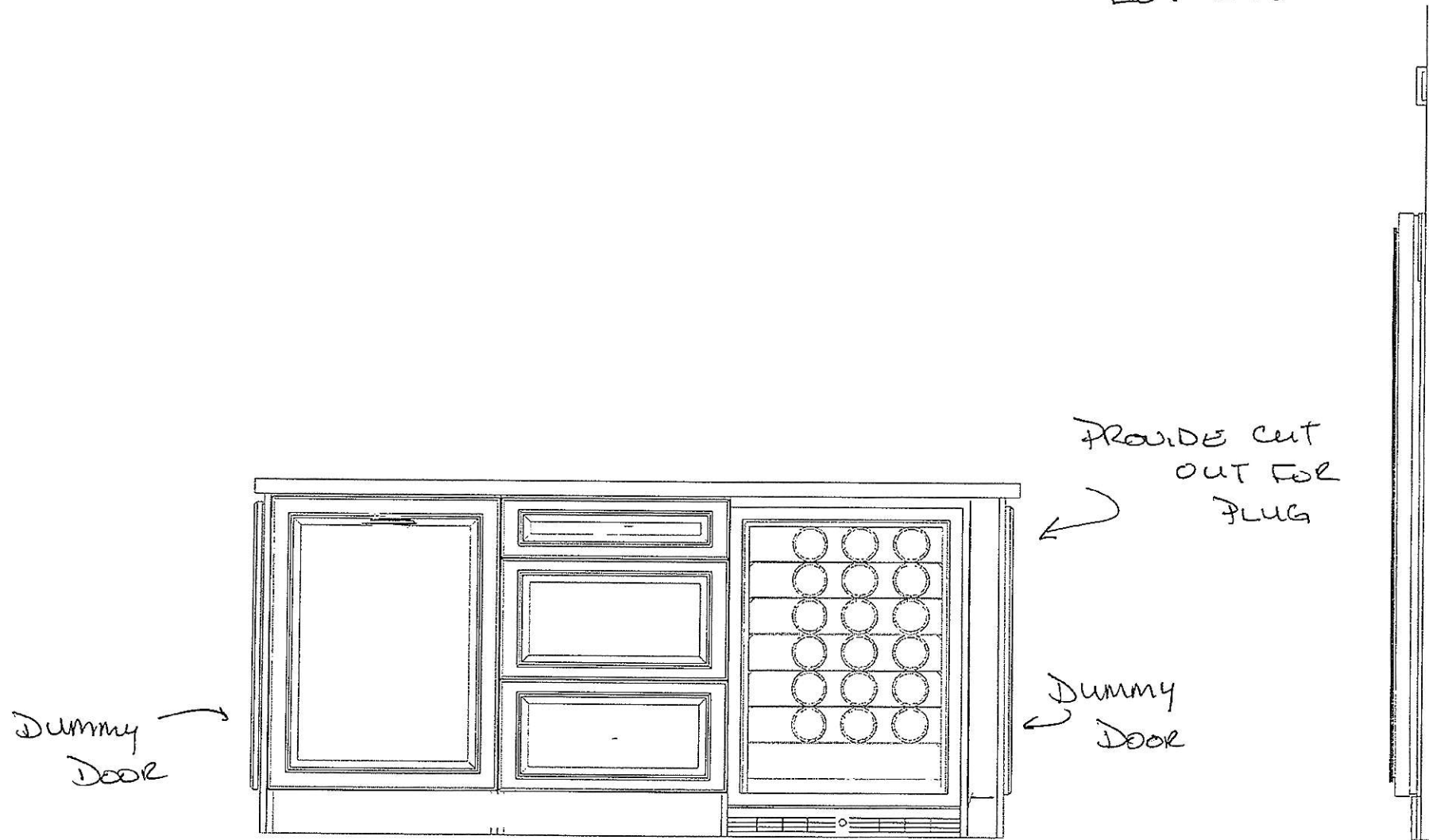

Dummy Door →

PROVIDE CUT
OUT FOR
PLUG ←

Dummy
Door ←

4 BIN
WASTE
RECYCLE

ISLAND - FACING STOVE



TASCO APPLIANCES

APPLIANCE SPECIFICATIONS

PROJECT PARTNER:

SHIP TO:

BU00007553 cont'd

REMINDER:

To ensure a smooth project it is the responsibility of the homeowner / purchaser of appliances to share all the attached specifications with their cabinet provider, contractor, or any other tradesperson so they have the information required to complete their work accurately. Product specifications are for planning purposes only and are subject to change without notice. Refer to installation instructions shipped with the product before cutting cabinets, counters, panels, etc.

Tasco Appliances assumes no liability for product specifications.

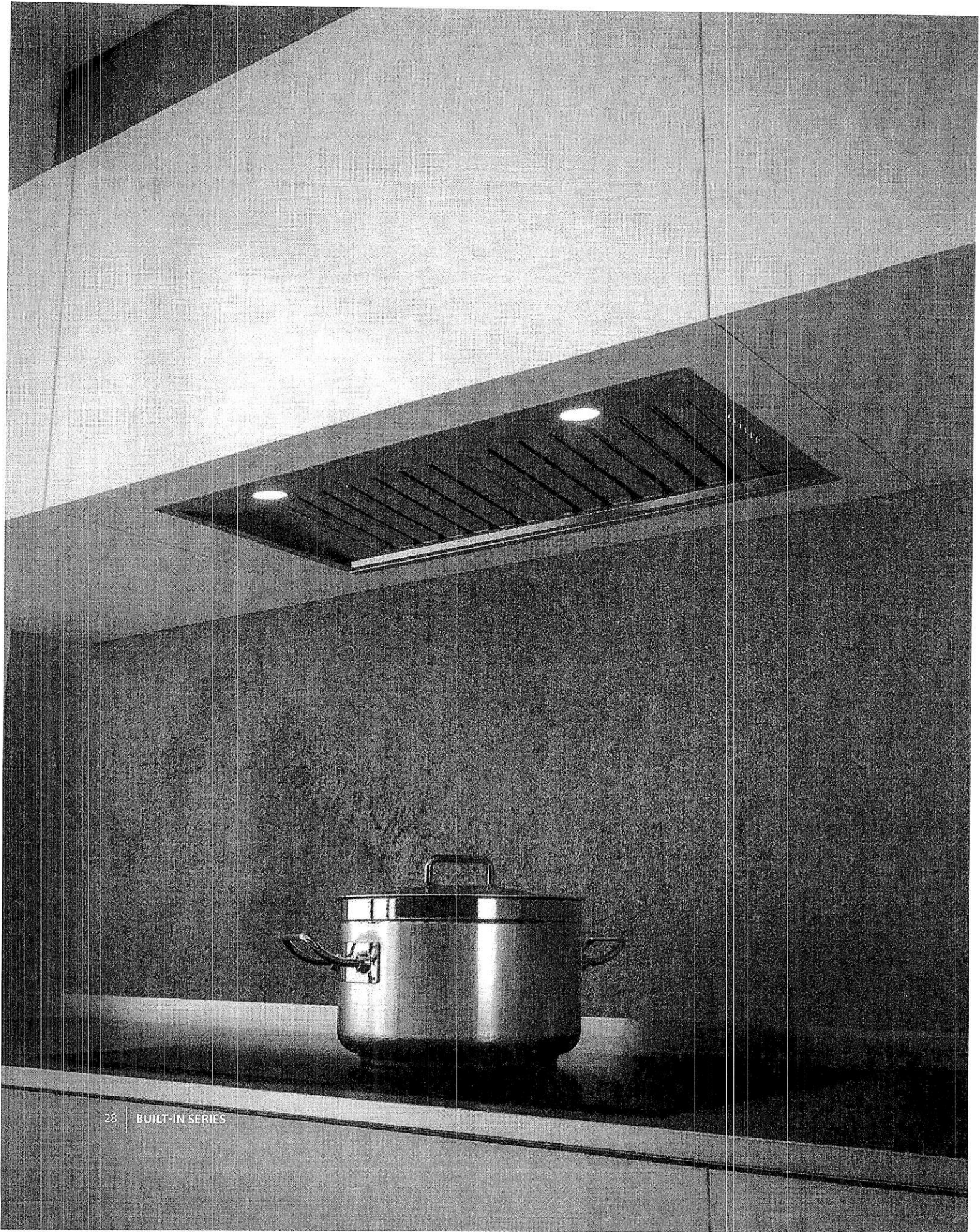

SU90934X
 SU90946X
 SU90955X

SU 909

stainless steel AISI 430

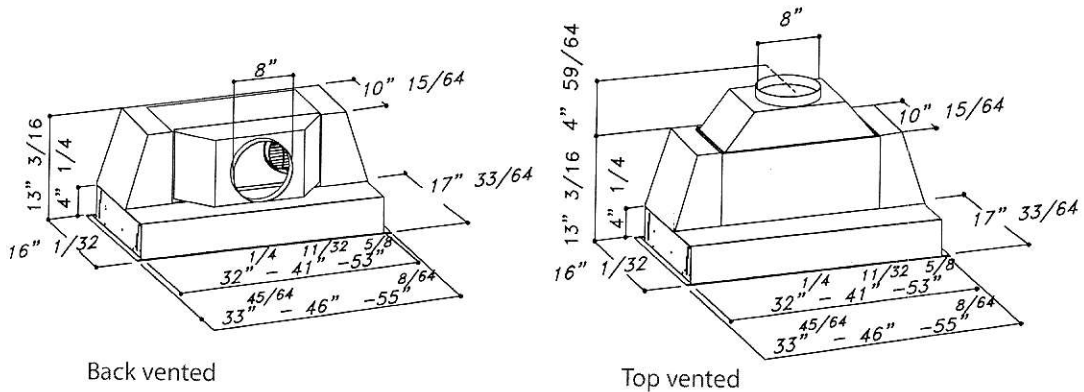

MOTOR	Dual Motor Aluminium die-cast housing 1100 CFM Pressure: 800 Pa Noise level: 66 dBA/5.1 sones
LIGHTING	2x1W Led spot for 34" and 46" 4x1W Led spot for 55"
CONTROL PANEL	Chromed push button 4 Speeds + timer +light
GREASE FILTER	Commercial style baffle filters
AIR OUTLET	8"
DISCHARGE	Vertical and horizontal
CUT OUT	32" 15/32 x 16" 1/8 SU909 34" version 44" 23/32 x 16" 1/8 SU909 46" version 53" 3/4 x 16" 1/8 SU909 55" version
ACCESSORIES	Charcoal filters: KF7 (Order 2 pcs for SU909 34" version) KF7 (Order 3 pcs for SU909 46"/55" version) Cod. 60080477002

KURR214KSB

KitchenAid[®]

24" Undercounter Refrigerator with Glass Door

<http://www.kitchenaid.com>

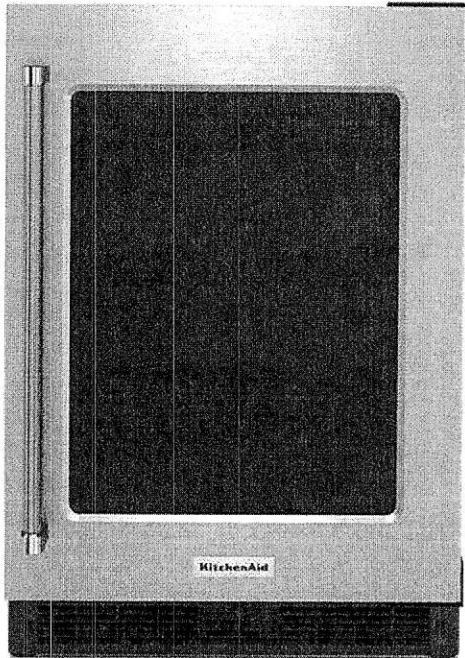

Key Features:

- Fully Flush Installation with Hidden Hinges
- Temperature Monitoring System
- Motion-Activated LED Lighting
- UV-Protected Thermal Glass Door
- Glass Shelves
- 5.2 Cu. Ft. Capacity
- Door Alarm
- Backlit Touch Controls
- Sabbath Mode (Star-K Certified)
- Automatic Defrost
- Energy Star Certified

Product Dimensions:

Width: 23 7/8

Depth: 26 7/16

Additional Information:

[Energy Guide](#)

[Warranty Certificate](#)

Available in:

Black Cabinet/Stainless Doors



©Registered trademark/TM Trademark of Whirlpool, U.S.A. © 2016 Whirlpool Corporation. All Rights Reserved. All other trademarks are owned by their respective companies.

Because Whirlpool Corporation policy includes a continuous commitment to improve our products, we reserve the right to change materials and specifications without notice. We also reserve the right to discontinue or transition products without notice.

Manufacturer's Suggested Retail Price (MSRP) and Minimum Advertised Price (MAP) provided for reference purposes only. Dealer alone determines advertised and retail prices.

Created On: Friday, March 05, 2021 05:32:30

Proper Disposal of your Old Refrigerator

WARNING: Risk of child entrapment. Before You Throw Away Your Old Refrigerator or Freezer:

- Take off the door.
- Leave the shelves in place so that children may not easily climb inside.

WARNING

Suffocation Hazard

Remove doors or lid from your old appliance.

Failure to do so can result in death or brain damage.

IMPORTANT: Child entrapment and suffocation are not problems of the past. Junked or abandoned refrigerators are still dangerous—even if they will sit for “just a few days.”

If you are getting rid of your old refrigerator, please follow these instructions to help prevent accidents.

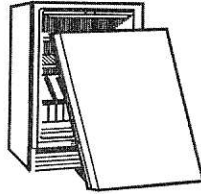

Important information to know about disposal of refrigerants:

Dispose of refrigerator in accordance with Federal and Local regulations. Refrigerants must be evacuated by a licensed, EPA certified refrigerant technician in accordance with established procedures.

INSTALLATION REQUIREMENTS

Tools and Parts

Gather the required tools and parts before starting installation.

Tools and parts needed:

- Phillips screwdriver.
- Custom Overlay Door Panel - Refer “Custom Overlay Panel Preparation”.
- Custom handle and mounting hardware (optional).

Parts supplied:

- M4 x 30 flathead screws (8).

Location Requirements

WARNING



Explosion Hazard

Keep flammable materials and vapors, such as gasoline, away from refrigerator.

Failure to do so can result in death, explosion, or fire.

IMPORTANT: This appliances is intended to be used in household and similar applications such as:

- Staff kitchen areas in shops, office and other working environments;
- Farm houses and by clients in hotels, motels and other residential type environments;
- Bed and breakfast type environments;
- Catering and similar non-retail applications.

NOTES:

- For the refrigerator to be flush with the front of the base cabinets, remove any baseboards or moldings from the rear of the opening. Refer “Product Dimensions” and later in this section, “Opening Dimensions.”
- It is recommended that you do not install the refrigerator near an oven, radiator, or other heat source.
- Do not install in a location where the temperature will fall below 55 °F (13 °C). For best performance, do not install the refrigerator behind a cabinet door or block the base grille.

Opening Dimensions:

- Height dimensions are shown with the leveling legs extended to the minimum height.

NOTE: When leveling legs are fully extended, add 5/8" (15 mm) to the height dimensions. Refer “Product Dimensions.”

- If the floor of the opening is not level with the kitchen floor, shim the opening to make it level with the kitchen floor.

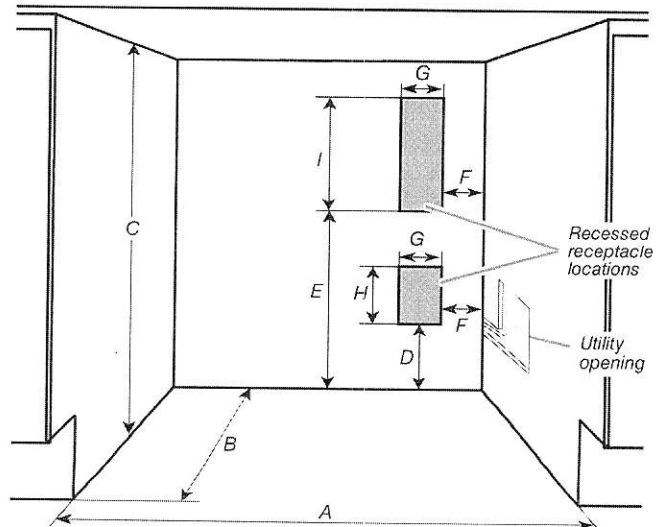

Opening and utility location dimensions	
Opening width - A	24" (60.96 cm) min.
Opening depth - B	24" (60.96 cm) min.
Opening height - C	34 ¹ / ₂ " (87.6 cm) min. 35" (88.9 cm) max.
Dimension - D	12 ¹ / ₁₆ " (30.64 cm)
Dimension - E	21 ³ / ₄ " (55.16 cm)
Dimension - F	1 ³ / ₄ " (4.44 cm)
Dimension - G	3" (7.55 cm)
Dimension - H	4 ¹ / ₂ " (11.37 cm)
Dimension - I	9 ¹ / ₄ " (23.47 cm)

For flush installation, the power outlet can be installed in adjacent cabinetry with a cutout on the power cord side for routing of the power cord.

The power outlet can also be recessed on the back wall behind the unit as per recommended receptacle locations in the above illustration.

Product Dimensions

Overall product	
Width (up to hinge cover)	23 ⁷ / ₈ " (60.72 cm)
Height (up to hinge cover)	34 ³ / ₈ " (87.32 cm)
Panel ready models depth (with 3/4" panel and no handle)	23 ¹³ / ₁₆ " (60.5 cm)
Raw Door Height	30 ⁵ / ₈ " (77.75 cm)
Depth (no handle)	23 ⁵ / ₈ " (60.01 cm)

NOTE: The power cord is 60" (152.4 cm) long.

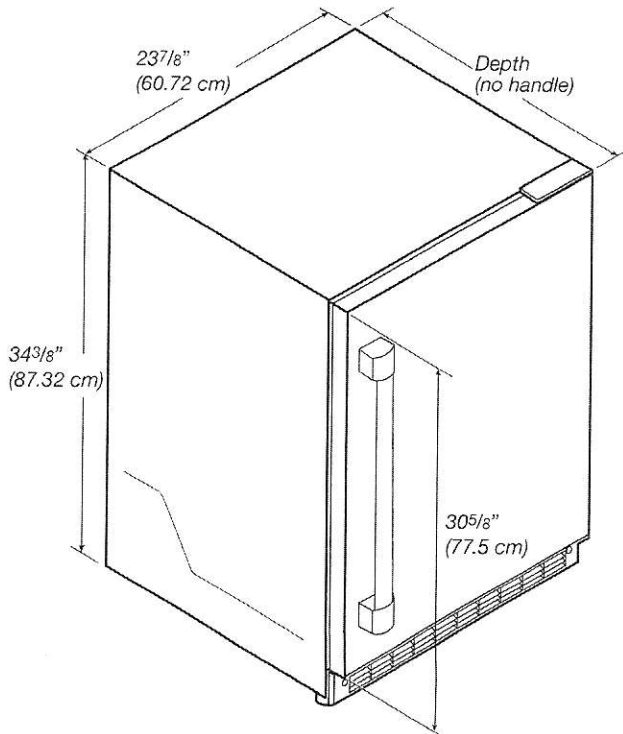

Custom Overlay Panel

NOTE: For standard stainless steel or glass door models, skip these instructions and go to "Electrical Requirements" section.

If you plan to install a custom overlay panel, you will need to create the panel yourself or consult a qualified cabinetmaker or carpenter. Refer dimension drawings for panel specifications.

IMPORTANT:

- The thickness of the overlay panel must be 3/4" (19 mm).
- Custom solid door overlay panel must not weigh more than 20 lb (9.07 kg).
- Custom glass door overlay panel must not weigh more than 10 lb (4.54 kg).
- Overlay panels weighing more than recommended may cause damage to your appliance.

Solid door overlay panel - Preparation:

Create the custom overlay panel using the dimensions shown in the illustration "Solid door overlay panel and hinge routing dimensions". Rout shaded areas to a 1/2" (12 mm) depth as shown.

IMPORTANT: The following graphic shows a custom panel for a door with the hinges installed on the right-hand side. If your refrigerator has the hinges installed on the left-hand side, rotate the custom frame 180° so the hinge markings will be on the left.

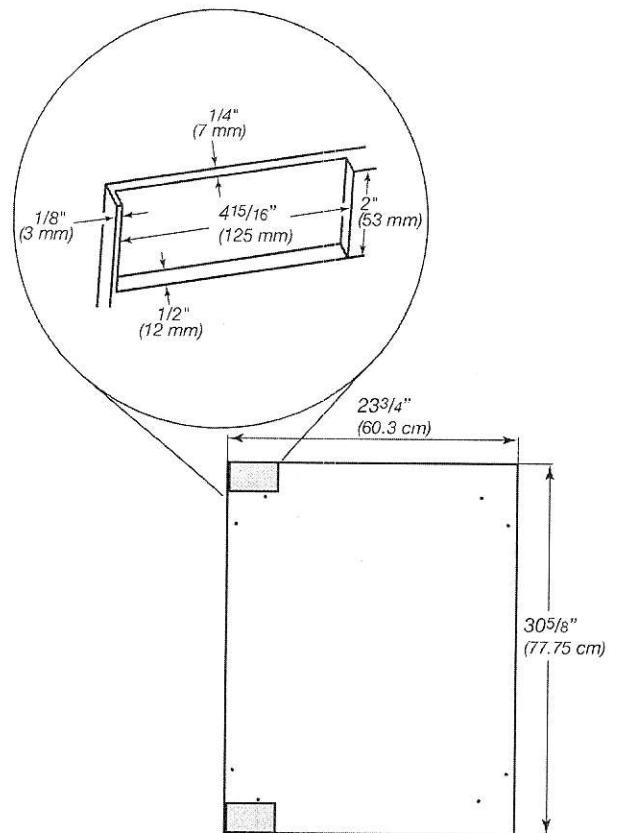

Solid door overlay panel and hinge routing dimensions