

ALL CONVENTIONAL FRAMING TO CONFORM WITH PART 9 OBC LATEST EDITION. ROOF RAFTERS THAT CROSS OVER TRUSSES TO BE 2X4 SPF #2 @ 24" O/C WITH A VERT POST TO THE TRUSS UNDERNEATH AT EACH CROSS POINT. VERT POST LONGER THAN 6' TO HAVE LATERAL BRACING, SO THAT THE DISTANCE BETWEEN END POINTS & ROWS OF BRACING DOES NOT EXCEED 6'

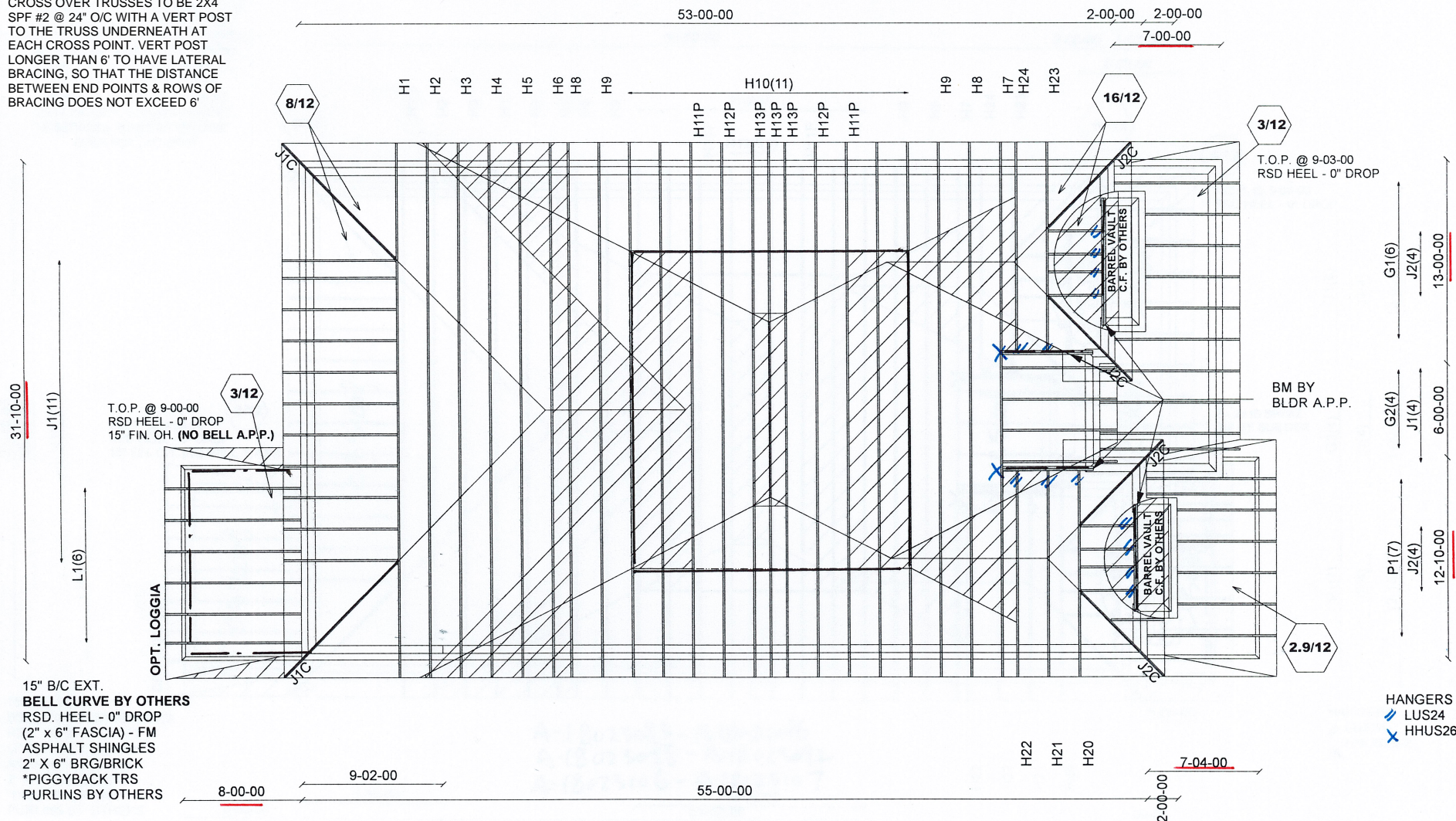

15" B/C EXT.  
**BELL CURVE BY OTHERS**  
 RSD. HEEL - 0" DROP  
 (2" x 6" FASCIA) - FM  
 ASPHALT SHINGLES  
 2" X 6" BRG/BRICK  
 \*PIGGYBACK TRS  
 PURLINS BY OTHERS

HANGERS  
 LUS24  
 HHUS26-2

E20035370 - E20035393

CONVENTIONAL FRAMING BY OTHERS

VALLEYVIEW

STD OR OPT. LOGGIA

	Job Track: <b>45147</b>	Builder / Location: <b>GOLD PARK HOMES / VAUGHAN</b>	Model / Elevation: <b>4002 REV1 / B</b>
	Layout ID: <b>318396</b>	Project: <b>PINE VALLEY</b>	
	Plan Log: <b>105728</b>	Date: 2020-03-16 Designer: AMANDA	THESE DRAWINGS CONSTITUTE THE PROPERTY OF ALPA ROOF TRUSSES INC. SHALL NOT BE REPRODUCED, PUBLISHED, OR REDISTRIBUTED IN ANY MANNER OR UTILIZED FOR ANY PURPOSE OTHER THAN THE MANUFACTURE OF TRUSSES BY ALPA ROOF TRUSSES INC AND WILL BE RETRACTED BY ALPA ROOF TRUSSES INC IF UTILIZED FOR ANY OTHER PURPOSE.

# EWP DESIGN INC.

(905) 832-2250

FAX (905) 832-0286

## RESPONSIBILITIES AND SPECIFICATIONS

### **RESPONSIBILITIES**

1. EWP DESIGN INC. is responsible for the design of trusses as individual components.
2. It is the responsibility of others to ascertain that the design loads utilized on each drawing meet or exceed the actual dead load imposed by the structure, the live load imposed by the intended use and the snow load imposed by local building code or authorities with jurisdictions.
3. All dimensions are to be verified by the owner, contractor, architect or other authorities with jurisdictions before truss fabrication.
4. EWP DESIGN INC. bears no responsibility for the erection of trusses. Persons erecting trusses are cautioned to seek professional advice regarding the temporary and permanent bracing for the system. Bracing shown on EWP DESIGN INC. drawing is specified for the truss as a component only and forms an integral part of the truss design.
5. It is the truss manufacturer's responsibility to ensure that trusses are manufactured in conformance with specifications of EWP DESIGN INC. as outlined below.

### **SPECIFICATIONS**

1. Trusses designed by EWP DESIGN INC. conform to the relevant section of the Ontario Building Code of Canada (Part 9 or Part 4) or to the Canadian code for farm buildings, whichever applies to the building type, as indicated on the EWP DESIGN INC. drawings, and conform to the design procedures established by the Truss Plate Institute of Canada. Unit stresses used for truss designs are as per the edition of CSA-O86 shown on EWP DESIGN INC. drawings.
2. Lumber is to be the size, species and grade as specified on EWP DESIGN INC. drawings.
3. Moisture content of lumber shall not exceed 19% in service unless specified otherwise.
4. Metal connector plates shall be applied to both faces of truss at each joint and shall be positioned as specified.
5. Top chords of trusses are assumed to be continuously braced laterally by roof sheathing or by purlins at intervals not exceeding 12.5 times the thickness of top chord member.
6. Bottom chords shall be laterally braced at intervals not exceeding 3M (10') o.c., where rigid ceiling is not applied directly to the underside of chords.

THESE DRAWINGS CONSTITUTE THE PROPERTY OF EWP DESIGN INC., SHALL NOT BE REPRODUCED, PUBLISHED, OR REDISTRIBUTED IN ANY MANNER OR UTILIZED FOR ANY PURPOSE OTHER THAN THE MANUFACTURE OF TRUSSES BY THE ALPA LUMBER GROUP, AND WILL BE RETRACTED BY EWP DESIGN INC. IF UTILIZED FOR ANY OTHER PURPOSE.

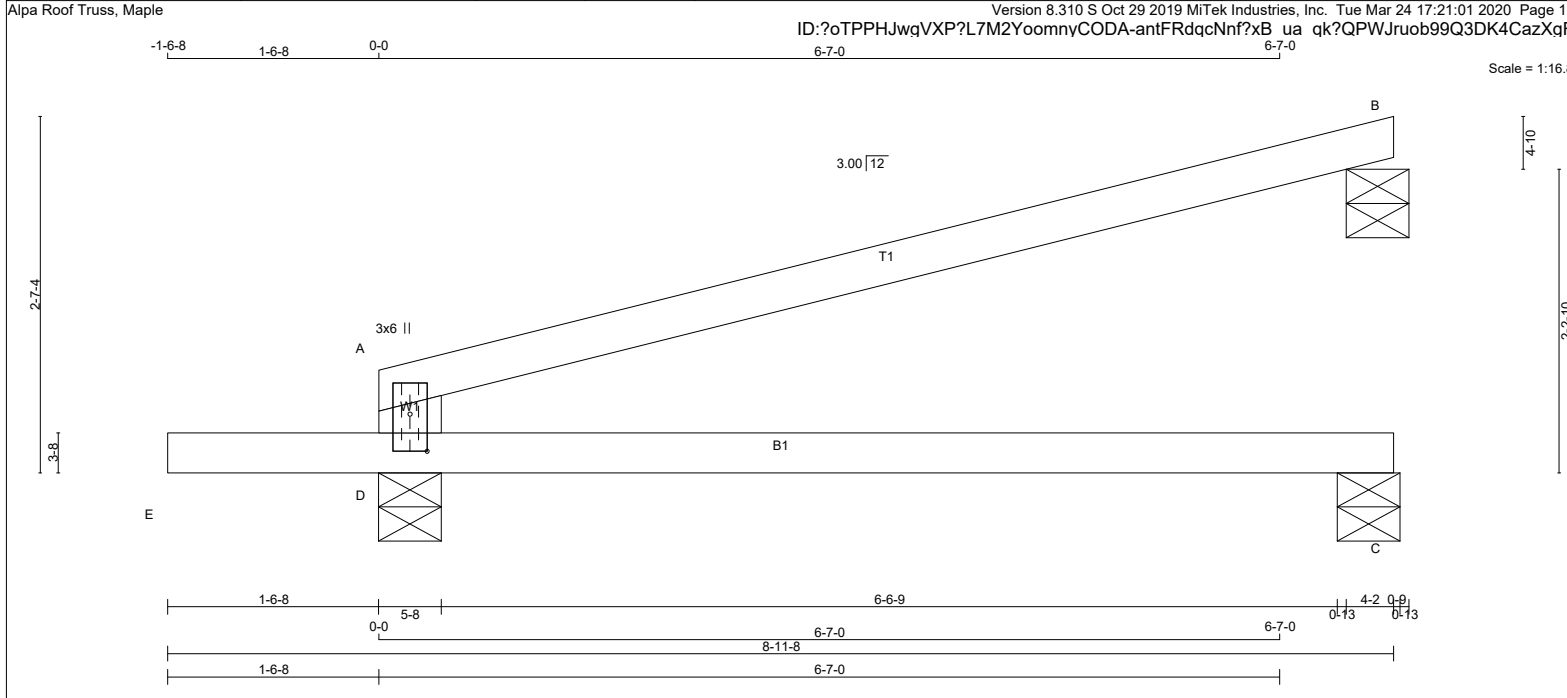

TOTAL WEIGHT = 6 X 20 = 117 lb

**LUMBER**

N. L. G. A. RULES	CHORDS	SIZE	DRY	LUMBER	No.2	DESCR.
A - B	2x4	DRY	No.2	SPF		
D - A	2x6	DRY	No.2	SPF		
E - C	2x4	DRY	No.2	SPF		

DRY: SEASONED LUMBER.

**PLATES (table is in inches)**

JT TYPE	PLATES	W	LEN	Y	X
A	TMBMV1+p	MT20	3.0	6.0	3.25 1.50
D					

**DIMENSIONS, SUPPORTS AND LOADINGS SPECIFIED BY FABRICATOR TO BE VERIFIED BY BUILDING DESIGNER**

**BEARINGS**

JT	FACTORED GROSS REACTION		MAXIMUM FACTORED GROSS REACTION		INPUT BRG	REQRD BRG
	VERT	HORZ	DOWN	HORZ		
B	220	0	220	0	5-8 (4-2)	4-2
C	51	0	58	0	5-8 (4-15)	1-8
D	593	0	593	0	5-8	1-8

VALUE IN PARENTHESIS INDICATES EFFECTIVE BEARING LENGTH

BEVELED PLATE OR SHIM REQUIRED TO PROVIDE FULL BEARING SURFACE WITH TRUSS CHORD AT JT(S): B

**UNFACTORED REACTIONS**

JT	COMBINED	MAX / MIN COMPONENT REACTIONS					
		1ST LCASE	SNOW	LIVE	PERM. LIVE	WIND	DEAD
B	152	118 / 0	0 / 0	0 / 0	0 / 0	34 / 0	0 / 0
C	41	0 / 0	0 / 0	0 / 0	0 / 0	41 / 0	0 / 0
D	423	258 / 0	0 / 0	0 / 0	0 / 0	165 / 0	0 / 0

BEARING MATERIAL TO BE SPF NO.2 OR BETTER AT JOINT(S) B, C, D

**BRACING**  
TOP CHORD TO BE SHEATHED OR MAX. PURLIN SPACING = 6.25 FT.  
MAX. UNBRACED BOTTOM CHORD LENGTH = 10.00 FT OR RIGID CEILING DIRECTLY APPLIED.

ALL PITCH BREAKS AND PERIMETER CORNER JOINTS MUST BE Laterally RESTRAINED.

**LOADING**  
TOTAL LOAD CASES: (4)

MEMB.	CHORDS				W E B S			
	MAX. FACTORED FORCE (LBS)	FACTORED VERT. LOAD (PLF)	LC1	MAX	MAX. UNBRAC LENGTH FR-TO	MEMB.	MAX. FACTORED FORCE (LBS)	MAX
A-B	-17 / 0	-78.0	-78.0	0.55 (1)	6.25			
D-A	-358 / 0	0.0	0.0	0.26 (1)	7.81			
E-D	0 / 0	-96.5	-96.5	0.16 (1)	10.00			
D-C	0 / 0	-18.5	-18.5	0.30 (4)	10.00			

**DESIGN CRITERIA**

**SPECIFIED LOADS:**

TOP CH.	LL	DL	PSF
		21.0	PSF
		6.0	PSF
BOT CH.	LL	DL	PSF
		0.0	PSF
		7.4	PSF
<b>TOTAL LOAD</b>		<b>34.4</b>	<b>PSF</b>

**SPACING = 24.0 IN. C/C**

THIS TRUSS IS DESIGNED FOR RESIDENTIAL OR SMALL BUILDING REQUIREMENTS OF PART 9, NBC 2015

THIS DESIGN COMPLIES WITH:  
- PART 9 OF BCBC 2018, ABC 2019  
- PART 9 OF OBC 2012 (2019 AMENDMENT)  
- CSA 086-14  
- TPIC 2014

**DESIGN ASSUMPTIONS**  
- OVERHANG NOT TO BE ALTERED OR CUT OFF.

(55% OF 23.0 P.S.F. G.S.L. PLUS 8.4 P.S.F. RAIN LOAD) EQUALS 21.0 P.S.F. SPECIFIED ROOF LIVE LOAD

ALLOWABLE DEFL.(TL)= L/360 (0.25")  
CALCULATED VERT. DEFL.(TL) = L/999 (0.06")

**CANTILEVER DEFLECTION:**  
ALLOWABLE DEFL.(LL)= L/120 (0.19")  
CALCULATED VERT. DEFL.(LL) = L/999 (0.01")  
ALLOWABLE DEFL.(TL)= L/120 (0.19")  
CALCULATED VERT. DEFL.(TL) = L/999 (0.01")

CSI: TC=0.55/1.00 (A-B-1), BC=0.30/1.00 (C-D-4), WB=0.00/1.00 (n/a-0), SSI=0.27/1.00 (A-B-1)

DOL LUMBER=1.00 NAIL=1.00 LS BEND=1.10 COMP=1.10 SHEAR=1.10 TENS= 1.10

COMPANION LIVE LOAD FACTOR = 1.00

AUTOSOLVE RIGHT HEEL ONLY

TRUSS PLATE MANUFACTURER IS NOT RESPONSIBLE FOR QUALITY CONTROL IN THE TRUSS MANUFACTURING PLANT.

**NAIL VALUES**

PLATE	GRIP(DRY)	SHEAR (PSI)	SECTION (PLI)
MT20	650	371	1747 788 1987 1873

PLATE PLACEMENT TOL. = 0.250 inches

PLATE ROTATION TOL. = 5.0 Deg.

JSI GRIP= 0.16 (A) (INPUT = 0.90)  
JSI METAL= 0.05 (A) (INPUT = 1.00)

LATERAL BRACE(S) SHOWN SHALL BE 2X4 SPF#2



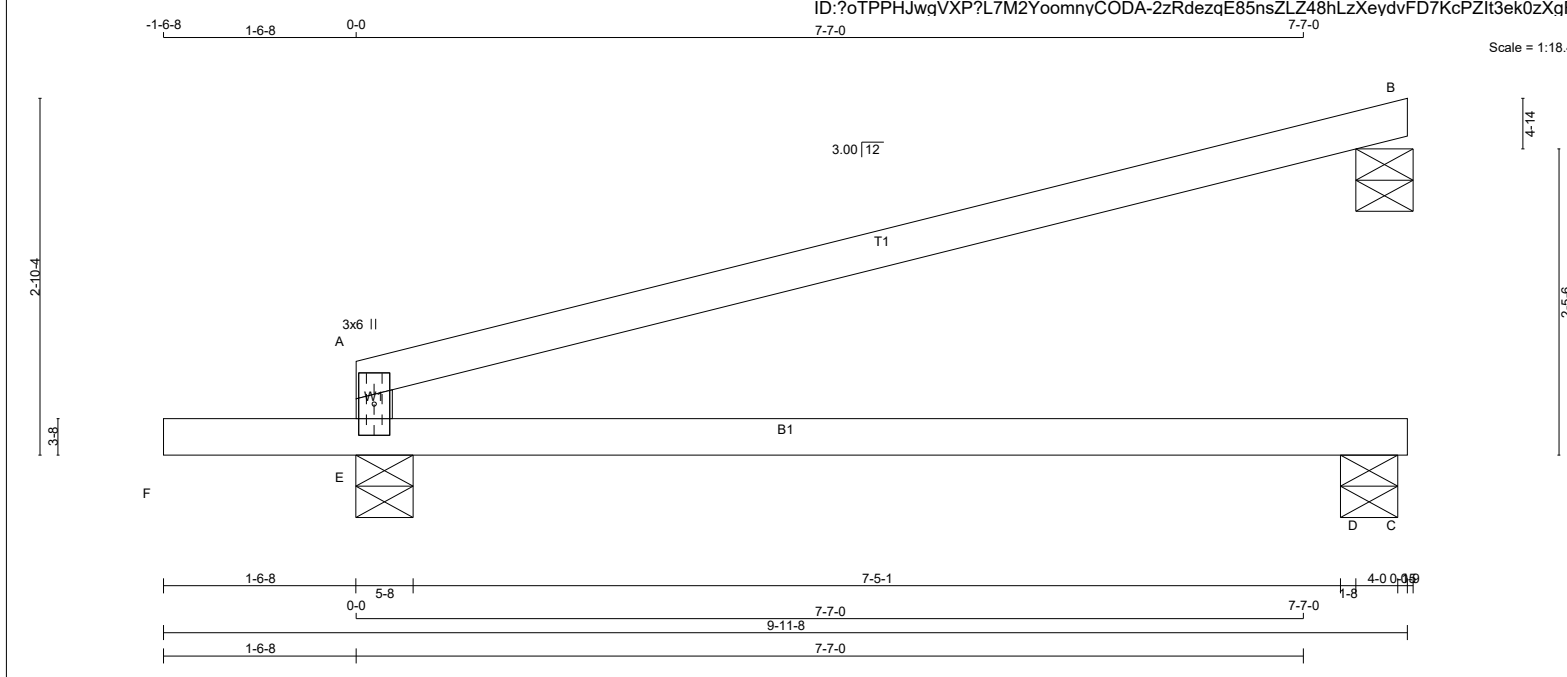

TOTAL WEIGHT = 4 X 22 = 86 lb [M]

**LUMBER**

N. L. G. A. RULES

CHORDS	SIZE	DRY	LUMBER No.2	DESCR. SPF
A - B	2x4	DRY	No.2	SPF
E - A	2x4	DRY	No.2	SPF
F - C	2x4	DRY	No.2	SPF

DRY: SEASONED LUMBER.

**PLATES (table is in inches)**

JT TYPE	PLATES	W	LEN	Y	X
A	TMBMV1+p	MT20	3.0	6.0	

**DIMENSIONS, SUPPORTS AND LOADINGS SPECIFIED BY FABRICATOR TO BE VERIFIED BY BUILDING DESIGNER**

**BEARINGS**

JT	FACTORED GROSS REACTION		MAXIMUM FACTORED GROSS REACTION		INPUT BRG	REQRD BRG
	VERT	HORZ	DOWN	HORZ		
B	257	0	257	0	5-8 (4-15)	4-15
E	642	0	642	0	5-8	1-8
D	62	0	69	0	5-8	1-8

VALUE IN PARENTHESIS INDICATES EFFECTIVE BEARING LENGTH

BEVELED PLATE OR SHIM REQUIRED TO PROVIDE FULL BEARING SURFACE WITH TRUSS CHORD AT JT(S): B

**UNFACTORED REACTIONS**

JT	COMBINED	MAX / MIN COMPONENT REACTIONS					SOIL
		1ST LCASE	SNOW	LIVE	PERM.LIVE	WIND	
B	178	138 / 0	0 / 0	0 / 0	0 / 0	40 / 0	0 / 0
E	457	280 / 0	0 / 0	0 / 0	0 / 0	178 / 0	0 / 0
D	50	0 / 0	0 / 0	0 / 0	0 / 0	50 / 0	0 / 0

BEARING MATERIAL TO BE SPF NO.2 OR BETTER AT JOINT(S) B, E, D

**BRACING**  
TOP CHORD TO BE SHEATHED OR MAX. PURLIN SPACING = 6.25 FT.  
MAX. UNBRACED BOTTOM CHORD LENGTH = 10.00 FT OR RIGID CEILING DIRECTLY APPLIED.

ALL PITCH BREAKS AND PERIMETER CORNER JOINTS MUST BE LATERALLY RESTRAINED.

**LOADING**

TOTAL LOAD CASES: (4)

MEMB.	CHORDS				WEBS			
	MAX. FACTORED FORCE (LBS)	FACTORED VERT. LOAD (PLF)	LC1	MAX CSI (LC)	MAX. UNBRAC LENGTH	MEMB. FR-TO	MAX. FACTORED FORCE (LBS)	MAX CSI (LC)
FR-TO		FROM	TO					
A-B	-17 / 0	-78.0	-78.0	0.81 (1)	6.25			
E-A	-399 / 0	0.0	0.0	0.81 (1)	7.78			
F-E	0 / 0	-96.5	-96.5	0.16 (1)	10.00			
E-D	0 / 0	-18.5	-18.5	0.36 (4)	10.00			
D-C	0 / 0	-18.5	-18.5	0.00 (4)	10.00			

**DESIGN CRITERIA**

SPECIFIED LOADS:

TOP CH.	LL = 21.0 PSF
	DL = 6.0 PSF
BOT CH.	LL = 0.0 PSF
	DL = 7.4 PSF
TOTAL LOAD	= 34.4 PSF

SPACING = 24.0 IN. C/C

THIS TRUSS IS DESIGNED FOR RESIDENTIAL OR SMALL BUILDING REQUIREMENTS OF PART 9, NBC 2015

THIS DESIGN COMPLIES WITH:  
- PART 9 OF BCBC 2018, ABC 2019  
- PART 9 OF OBC 2012 (2019 AMENDMENT)  
- CSA 086-14  
- TPIC 2014

DESIGN ASSUMPTIONS  
- OVERHANG NOT TO BE ALTERED OR CUT OFF.

(55% OF 23.0 P.S.F. G.S.L. PLUS 8.4 P.S.F. RAIN LOAD) EQUALS 21.0 P.S.F. SPECIFIED ROOF LIVE LOAD

ALLOWABLE DEFL.(TL)= L/360 (0.27")  
CALCULATED VERT. DEFL.(TL) = L/999 (0.08")

CANTILEVER DEFLECTION:  
ALLOWABLE DEFL.(LL)= L/120 (0.19")  
CALCULATED VERT. DEFL.(LL) = L/999 (0.01")  
ALLOWABLE DEFL.(TL)= L/120 (0.19")  
CALCULATED VERT. DEFL.(TL) = L/999 (0.01")

CSI: TC=0.81/1.00 (A-B:1), BC=0.36/1.00 (D-E:4), WB=0.00/1.00 (n/a:0), SSI=0.30/1.00 (A-B:1)

DOL LUMBER=1.00 NAIL=1.00 LS BEND=1.10 COMP=1.10 SHEAR=1.10 TENS= 1.10

COMPANION LIVE LOAD FACTOR = 1.00

AUTOSOLVE RIGHT HEEL ONLY

TRUSS PLATE MANUFACTURER IS NOT RESPONSIBLE FOR QUALITY CONTROL IN THE TRUSS MANUFACTURING PLANT .

NAIL VALUES  
PLATE GRIP(DRY) SHEAR SECTION (PSI) (PLI) (PLI)  
MAX MIN MAX MIN MAX MIN  
MT20 650 371 1747 788 1987 1873

PLATE PLACEMENT TOL. = 0.250 inches  
PLATE ROTATION TOL. = 5.0 Deg.

JSI GRIP= 0.18 (A) (INPUT = 0.90 )  
JSI METAL= 0.06 (A) (INPUT = 1.00 )

LATERAL BRACE(S) SHOWN SHALL BE 2X4 SPF#2



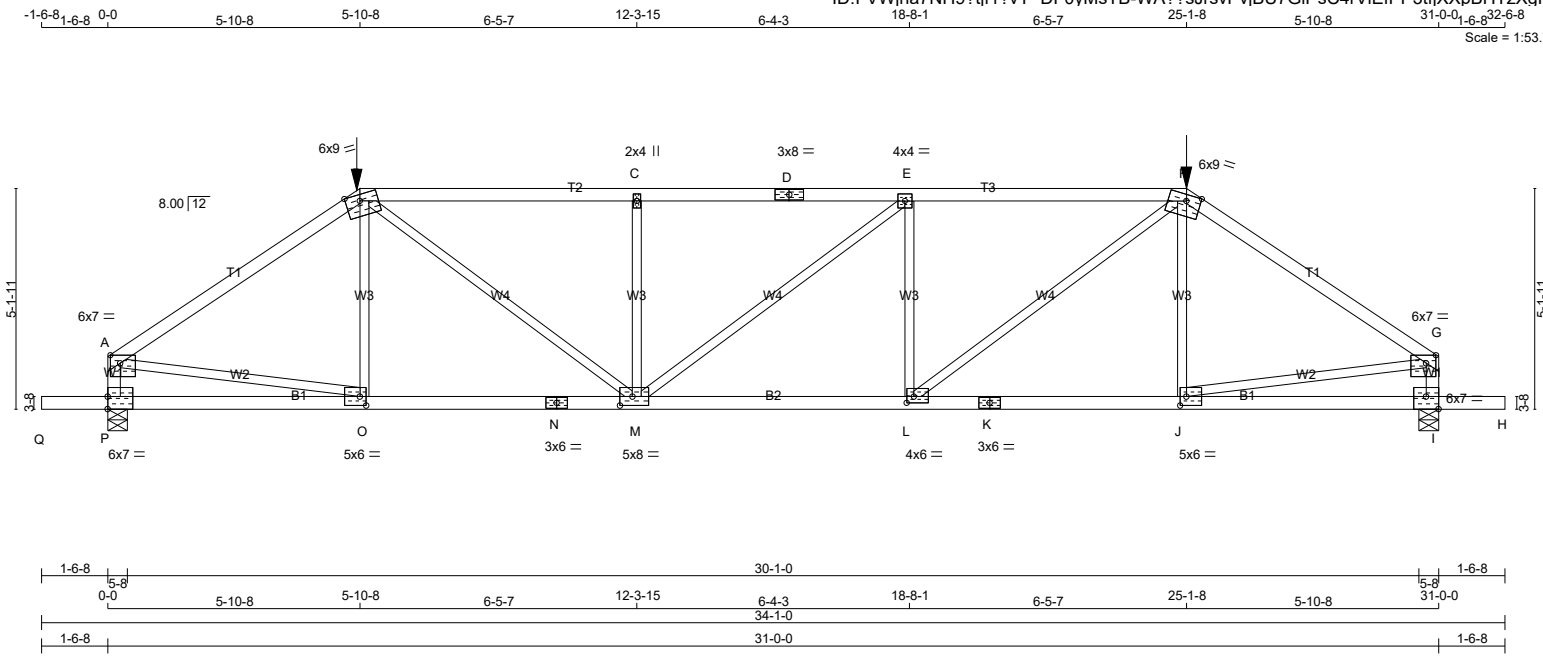

TOTAL WEIGHT = 122 lb

**LUMBER**

N. L. G. A. RULES	CHORDS	SIZE	LUMBER	DESCR.
A - B	2x4	DRY	1650F 1.5E	SPF
B - D	2x4	DRY	2100F 1.8E	SPF
D - F	2x4	DRY	2100F 1.8E	SPF
F - G	2x4	DRY	1650F 1.5E	SPF
P - A	2x4	DRY	No.2	SPF
I - G	2x4	DRY	No.2	SPF
Q - N	2x4	DRY	No.2	SPF
N - K	2x4	DRY	No.2	SPF
K - H	2x4	DRY	No.2	SPF
ALL WEBS EXCEPT	2x3	DRY	No.2	SPF

DRY: SEASONED LUMBER.

**PLATES (table is in inches)**

JT	TYPE	PLATES	W	LEN	Y	X
A	TMVW-p	MT20	6.0	7.0	2.25	2.75
B	TTWW-m	MT20	6.0	9.0	1.75	4.00
C	TMW+w	MT20	2.0	4.0		
D	TS-t	MT20	3.0	8.0		
E	TMWW-t	MT20	4.0	4.0		
F	TTWW-m	MT20	6.0	9.0	1.75	4.00
G	TMVW-p	MT20	6.0	7.0	2.25	2.75
I	BMV1-t	MT20	6.0	7.0	Edge	3.50
J	BMWW-t	MT20	5.0	6.0	2.50	1.75
K	BS-t	MT20	3.0	6.0		
L	BMWW-t	MT20	4.0	6.0	1.75	2.00
M	BMWWW-t	MT20	5.0	8.0	2.50	3.50
N	BS-t	MT20	3.0	6.0		
O	BMWW-t	MT20	5.0	6.0	2.50	1.75
P	BMV1-t	MT20	6.0	7.0	Edge	

Edge - INDICATES REFERENCE CORNER OF PLATE TOUCHES EDGE OF CHORD.

**DIMENSIONS, SUPPORTS AND LOADINGS SPECIFIED BY FABRICATOR TO BE VERIFIED BY BUILDING DESIGNER**

**BEARINGS**

JT	FACTORED GROSS REACTION		MAXIMUM FACTORED GROSS REACTION		INPUT BRG	REQRD BRG
	VERT	HORZ	DOWN	HORZ		
P	2983	0	2983	0	5-8	5-8
I	2983	0	2983	0	5-8	5-8

**UNFACTORED REACTIONS**

JT	COMBINED	MAX./MIN. COMPONENT REACTIONS					
		1ST LCASE	SNOW	LIVE	PERM.LIVE	WIND	DEAD
P	2129	1287 / 0	0 / 0	0 / 0	0 / 0	842 / 0	0 / 0
I	2129	1287 / 0	0 / 0	0 / 0	0 / 0	842 / 0	0 / 0

BEARING MATERIAL TO BE SPF NO.2 OR BETTER AT JOINT(S) P, I  
 BEARING SIZE FACTOR = 1.15 AT JNT(S) P, I (BASED ON SUPPORT DEPTH = 1-8)

**BRACING**  
 TOP CHORD TO BE SHEATHED OR MAX. PURLIN SPACING = 2.98 FT.  
 MAX. UNBRACED BOTTOM CHORD LENGTH = 10.00 FT. OR RIGID CEILING DIRECTLY APPLIED.  
 ALL PITCH BREAKS AND PERIMETER CORNER JOINTS MUST BE Laterally RESTRAINED.

**LOADING**  
 TOTAL LOAD CASES: (4)

MEMB.	CHORDS				WEBS			
	MAX. FACTORED FORCE (LBS)	FACTORED VERT. LOAD (PLF)	FACTORED LC1 MAX	UNBRAC LENGTH	MEMB. MAX. FACTORED FORCE (LBS)	FACTORED MAX	UNBRAC LENGTH	CSF (LC)
FR-TO		FROM	TO		FR-TO			
A-B	-3695 / 0	-78.0	-78.0	0.74 (1)	3.56	O-B	-211 / 102	0.09 (1)
B-C	-4787 / 0	-153.5	-153.5	0.97 (1)	2.99	B-M	0 / 2150	0.53 (1)
C-D	-4787 / 0	-153.5	-153.5	0.96 (1)	2.98	M-C	-1064 / 0	0.43 (1)
D-E	-4787 / 0	-153.5	-153.5	0.96 (1)	2.98	M-E	-1 / 0	0.00 (1)
E-F	-4788 / 0	-153.5	-153.5	0.97 (1)	2.98	L-E	-1064 / 0	0.43 (1)
F-G	-3694 / 0	-78.0	-78.0	0.74 (1)	3.56	L-F	0 / 2152	0.53 (1)
P-A	-2747 / 0	0.0	0.0	0.31 (1)	5.13	J-F	-212 / 102	0.09 (1)
I-G	-2747 / 0	0.0	0.0	0.31 (1)	5.13	A-O	0 / 3105	0.77 (1)
						J-G	0 / 3105	0.77 (1)
Q-P	0 / 0	-96.5	-96.5	0.17 (1)	10.00			
P-O	0 / 0	-36.4	-36.4	0.36 (4)	10.00			
O-N	0 / 3066	-36.4	-36.4	0.74 (1)	10.00			
N-M	0 / 3066	-36.4	-36.4	0.74 (1)	10.00			
M-L	0 / 4788	-36.4	-36.4	0.99 (1)	10.00			
L-K	0 / 3066	-36.4	-36.4	0.74 (1)	10.00			
K-J	0 / 3066	-36.4	-36.4	0.74 (1)	10.00			
J-I	0 / 0	-36.4	-36.4	0.36 (4)	10.00			
I-H	0 / 0	-96.5	-96.5	0.17 (1)	10.00			

**FACTORED CONCENTRATED LOADS (LBS)**

JT	LOC.	LC1	MAX-	MAX+	FACE	DIR.	TYPE	HEEL	CONN.
B	5-10-8	-334	-334	---	FRONT	VERT	TOTAL	---	C1
F	25-1-8	-334	-334	---	FRONT	VERT	TOTAL	---	C1

**CONNECTION REQUIREMENTS**

- C1: A SUITABLE HANGER/MECHANICAL CONNECTION IS REQUIRED.

**DESIGN CRITERIA**

**SPECIFIED LOADS:**  
 TOP CH. LL = 21.0 PSF  
 DL = 6.0 PSF  
 BOT CH. LL = 0.0 PSF  
 DL = 7.4 PSF  
 TOTAL LOAD = 34.4 PSF

**SPACING = 24.0 IN./C/C**

LOADING IN FLAT SECTION BASED ON A SLOPE OF 2.00/12 MINIMUM

GIRDER TYPE: CPrimeHip  
 SIDE SETBACK = 5-10-8  
 END SETBACK = 5-10-8  
 END WALL WIDTH = 0-0  
 CORNER FRAMING TYPE: CONVENTIONAL  
 END JACK TYPE: CONVENTIONAL  
 APPLIED TO FRONT SIDE  
 - ADDTL LOADS BASED ON 55 % OF GSL.

THIS TRUSS IS DESIGNED FOR RESIDENTIAL OR SMALL BUILDING REQUIREMENTS OF PART 9, NBC2015

THIS DESIGN COMPLIES WITH:  
 - PART 9 OF BCBC 2018, ABC 2019  
 - PART 9 OF OBC 2012 (2019 AMENDMENT)  
 - CSA 086-14  
 - TPIC 2014

(55 % OF 23.0 P.S.F. G.S.L. PLUS 8.4 P.S.F. RAIN LOAD) EQUALS 21.0 P.S.F. SPECIFIED ROOF LIVE LOAD

ALLOWABLE DEFL.(LL) = L/360 (1.03")  
 CALCULATED VERT. DEFL.(LL) = L/999 (0.20")  
 ALLOWABLE DEFL.(TL) = L/360 (1.03")  
 CALCULATED VERT. DEFL.(TL) = L/870 (0.43")

**CANTILEVER DEFLECTION:**  
 ALLOWABLE DEFL.(LL) = L/120 (0.19")  
 CALCULATED VERT. DEFL.(LL) = L/999 (0.01")  
 ALLOWABLE DEFL.(TL) = L/120 (0.19")  
 CALCULATED VERT. DEFL.(TL) = L/999 (0.01")

CSI: TC=0.97/1.00 (E-F:1), BC=0.99/1.00 (L-M:1), WB=0.77/1.00 (A-O:1), SSI=0.50/1.00 (E-F:1)

DOL LUMBER=1.00 NAIL=1.00 LS BEND=1.00  
 COMP=1.00 SHEAR=1.00 TENS=1.00

COMPANION LIVE LOAD FACTOR = 1.00

TRUSS PLATE MANUFACTURER IS NOT RESPONSIBLE FOR QUALITY CONTROL IN THE TRUSS MANUFACTURING PLANT.

**NAIL VALUES**

PLATE	GRIP(DRY)	SHEAR	SECTION
(PSI)	(PLI)	(PLI)	
MAX MIN	MAX MIN	MAX MIN	
MT20	650 371	1747 788	1987 1873

PLATE PLACEMENT TOL. = 0.250 inches

PLATE ROTATION TOL. = 5.0 Deg.



LATERAL BRACE(S) SHOWN SHALL BE 2X4 SPF#2

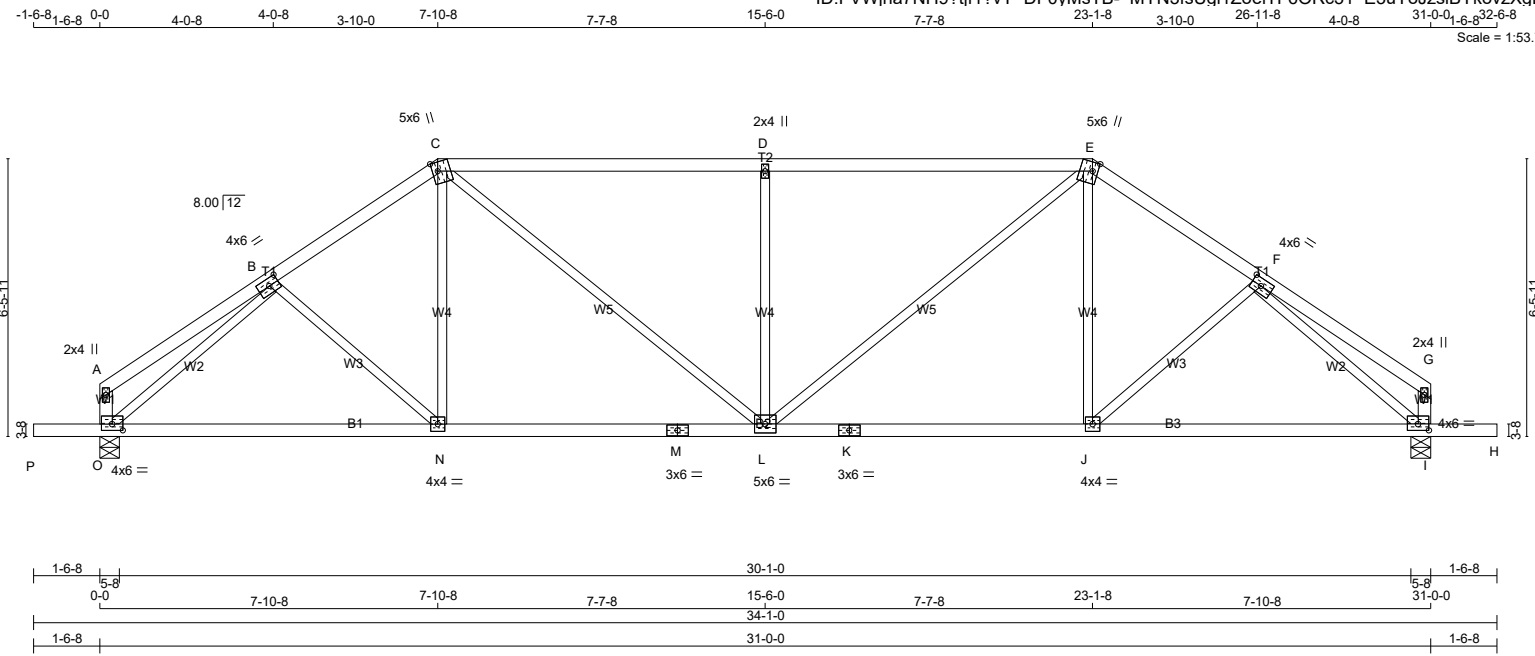

TOTAL WEIGHT = 126 lb [M][F]

**LUMBER**

N. L. G. A. RULES	CHORDS	SIZE	LUMBER	DESCR.
A - C	2x4	DRY	No.2	SPF
C - E	2x4	DRY	No.2	SPF
E - G	2x4	DRY	No.2	SPF
O - A	2x4	DRY	No.2	SPF
I - G	2x4	DRY	No.2	SPF
P - M	2x4	DRY	No.2	SPF
M - K	2x4	DRY	No.2	SPF
K - H	2x4	DRY	No.2	SPF
ALL WEBS EXCEPT	2x3	DRY	No.2	SPF

DRY: SEASONED LUMBER.

**PLATES (table is in inches)**

JT	TYPE	PLATES	W	LEN	Y	X
A	TMV+p	MT20	2.0	4.0		
B	TMWW-t	MT20	4.0	6.0	2.00	2.75
C	TTWW+m	MT20	5.0	6.0	2.50	1.50
D	TMW+w	MT20	2.0	4.0		
E	TTWW+m	MT20	5.0	6.0	2.50	1.50
F	TMWW-t	MT20	4.0	6.0	2.00	2.75
G	TMV+p	MT20	2.0	4.0		
I	BMVW1-t	MT20	4.0	6.0	1.75	3.00
J	BMWW-t	MT20	4.0	4.0		
K	BS-t	MT20	3.0	6.0		
L	BMWWW-t	MT20	5.0	6.0		
M	BS-t	MT20	3.0	6.0		
N	BMWW-t	MT20	4.0	4.0		
O	BMVW1-t	MT20	4.0	6.0	1.75	3.00

LATERAL BRACE(S) SHOWN SHALL BE 2X4 SPF#2



**DIMENSIONS, SUPPORTS AND LOADINGS SPECIFIED BY FABRICATOR TO BE VERIFIED BY BUILDING DESIGNER**

**BEARINGS**

JT	FACTORED GROSS REACTION		MAXIMUM FACTORED GROSS REACTION		INPUT BRG	REQRD BRG
	VERT	HORZ	DOWN	HORZ		
O	1644	0	1644	0	5-8	1-12
I	1644	0	1644	0	5-8	1-12

**UNFACTORED REACTIONS**

JT	1ST LCASE		MAX./MIN. COMPONENT REACTIONS		WIND	DEAD	SOIL
	COMBINED	SNOW	LIVE	PERM.LIVE			
O	1172	715/0	0/0	0/0	0/0	457/0	0/0
I	1172	715/0	0/0	0/0	0/0	457/0	0/0

BEARING MATERIAL TO BE SPF NO.2 OR BETTER AT JOINT(S) O, I

**BRACING**  
 TOP CHORD TO BE SHEATHED OR MAX. PURLIN SPACING = 3.96 FT.  
 MAX. UNBRACED BOTTOM CHORD LENGTH = 10.00 FT OR RIGID CEILING DIRECTLY APPLIED.  
 ALL PITCH BREAKS AND PERIMETER CORNER JOINTS MUST BE LATERALLY RESTRAINED.

**LOADING**  
 TOTAL LOAD CASES: (4)

MEMB.	CHORDS		FACTORED		MAX. UNBRAC LENGTH	WEBS		
	MAX. FACTORED FORCE (LBS)	VERT. LOAD (PLF)	LC1	MAX		MEMB. FORCE (LBS)	MAX FACTORED CSI (LC)	
FR-TO								
A-B	0/18	-78.0	-78.0	0.18 (1)	10.00	B-N	-35/39	0.02 (1)
B-C	-1753/0	-78.0	-78.0	0.17 (1)	4.90	N-C	0/188	0.06 (4)
C-D	-1973/0	-78.0	-78.0	0.70 (1)	3.96	C-L	0/681	0.15 (1)
D-E	-1973/0	-78.0	-78.0	0.70 (1)	3.96	L-D	-732/0	0.50 (1)
E-F	-1753/0	-78.0	-78.0	0.17 (1)	4.90	L-E	0/681	0.15 (1)
F-G	0/18	-78.0	-78.0	0.18 (1)	10.00	J-E	0/188	0.06 (4)
O-A	-121/0	0.0	0.0	0.01 (1)	7.81	J-F	-35/39	0.02 (1)
I-G	-121/0	0.0	0.0	0.01 (1)	7.81	O-B	-1970/0	0.89 (1)
						F-I	-1970/0	0.89 (1)
P-O	0/0	-96.5	-96.5	0.16 (1)	10.00			
O-N	0/1467	-18.5	-18.5	0.42 (4)	10.00			
N-M	0/1444	-18.5	-18.5	0.42 (4)	10.00			
M-L	0/1444	-18.5	-18.5	0.42 (4)	10.00			
L-K	0/1444	-18.5	-18.5	0.42 (4)	10.00			
K-J	0/1444	-18.5	-18.5	0.42 (4)	10.00			
J-I	0/1467	-18.5	-18.5	0.42 (4)	10.00			
I-H	0/0	-96.5	-96.5	0.16 (1)	10.00			

**DESIGN CRITERIA**

**SPECIFIED LOADS:**  
 TOP CH. LL = 21.0 PSF  
 DL = 6.0 PSF  
 BOT CH. LL = 0.0 PSF  
 DL = 7.4 PSF  
 TOTAL LOAD = 34.4 PSF

**SPACING = 24.0 IN./C**

LOADING IN FLAT SECTION BASED ON A SLOPE OF 2.00/12 MINIMUM

THIS TRUSS IS DESIGNED FOR RESIDENTIAL OR SMALL BUILDING REQUIREMENTS OF PART 9, NBC 2015

THIS DESIGN COMPLIES WITH:  
 - PART 9 OF CBC 2018, ABC 2019  
 - PART 9 OF OBC 2012 (2019 AMENDMENT)  
 - CSA 086-14  
 - TPIC 2014

(55% OF 23.0 P.S.F. G.S.L. PLUS 8.4 P.S.F. RAIN LOAD) EQUALS 21.0 P.S.F. SPECIFIED ROOF LIVE LOAD

ALLOWABLE DEFL.(LL)= L/360 (1.03")  
 CALCULATED VERT. DEFL.(LL) = L/999 (0.08")  
 ALLOWABLE DEFL.(TL)= L/360 (1.03")  
 CALCULATED VERT. DEFL.(TL) = L/999 (0.17")

CANTILEVER DEFLECTION:  
 ALLOWABLE DEFL.(LL)= L/120 (0.19")  
 CALCULATED VERT. DEFL.(LL) = L/999 (0.01")  
 ALLOWABLE DEFL.(TL)= L/120 (0.19")  
 CALCULATED VERT. DEFL.(TL) = L/999 (0.01")

CSI: TC=0.70/1.00 (C-D:1), BC=0.42/1.00 (J-L:4), WB=0.89/1.00 (F-I:1), SSI=0.29/1.00 (C-D:1)

DOL LUMBER=1.00 NAIL=1.00 LS BEND=1.10 COMP=1.10 SHEAR=1.10 TENS=1.10

COMPANION LIVE LOAD FACTOR = 1.00

TRUSS PLATE MANUFACTURER IS NOT RESPONSIBLE FOR QUALITY CONTROL IN THE TRUSS MANUFACTURING PLANT.

**NAIL VALUES**  
 PLATE GRIP(DRY) SHEAR SECTION (PSI) (PLI) (PLI)  
 MAX MIN MAX MIN MAX MIN  
 MT20 650 371 1747 788 1987 1873

PLATE PLACEMENT TOL. = 0.250 inches  
 PLATE ROTATION TOL. = 5.0 Deg.

JSI GRIP= 0.89 (F) (INPUT = 0.90)  
 JSI METAL= 0.48 (M) (INPUT = 1.00)

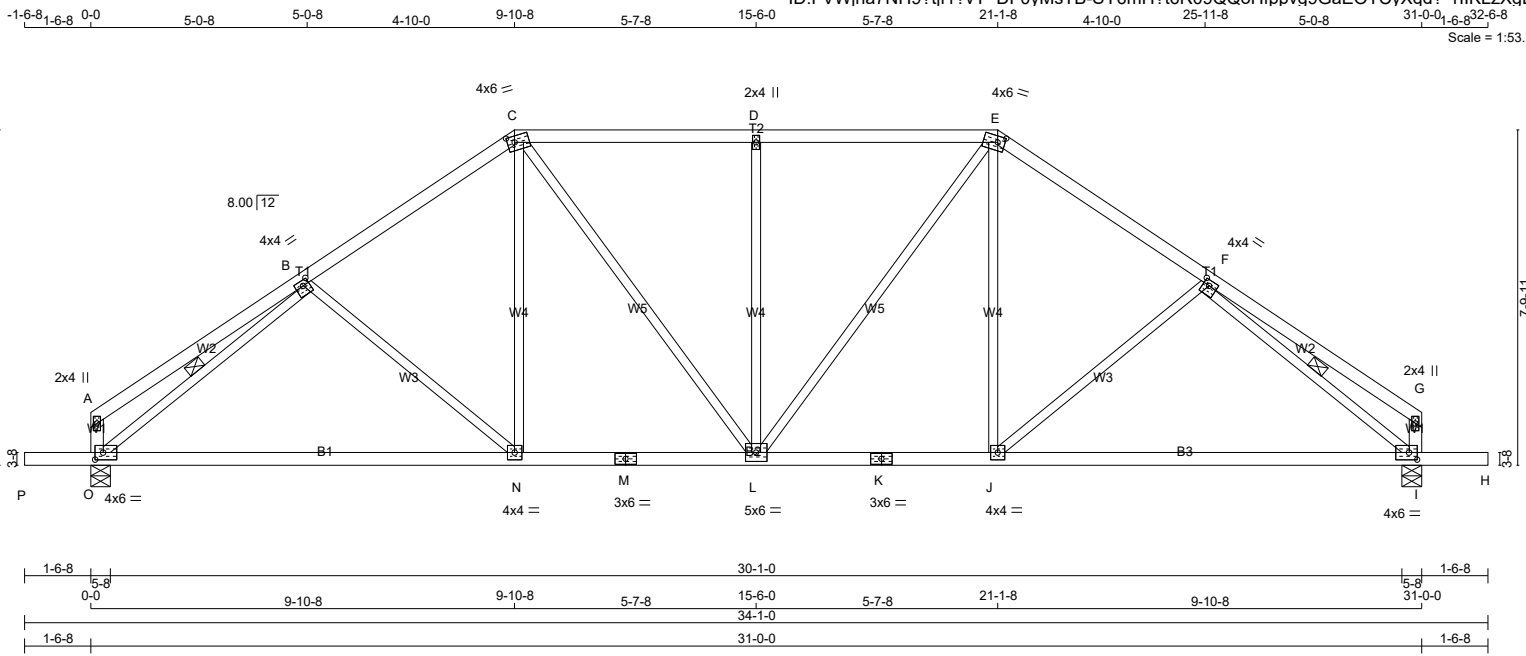

TOTAL WEIGHT = 133 lb

**LUMBER**

N. L. G. A. RULES	CHORDS	SIZE	LUMBER	DESCR.
A - C	2x4	DRY	No.2	SPF
C - E	2x4	DRY	No.2	SPF
E - G	2x4	DRY	No.2	SPF
O - A	2x4	DRY	No.2	SPF
I - G	2x4	DRY	No.2	SPF
P - M	2x4	DRY	No.2	SPF
M - K	2x4	DRY	No.2	SPF
K - H	2x4	DRY	No.2	SPF
ALL WEBS EXCEPT	2x3	DRY	No.2	SPF

DRY: SEASONED LUMBER.

**PLATES (table is in inches)**

JT	TYPE	PLATES	W	LEN	Y	X
A	TMV+p	MT20	2.0	4.0		
B	TMWW-t	MT20	4.0	4.0	1.50	1.75
C	TTWW-m	MT20	4.0	6.0	1.75	2.00
D	TMW+w	MT20	2.0	4.0		
E	TTWW-m	MT20	4.0	6.0	1.75	2.00
F	TMWW-t	MT20	4.0	4.0	1.50	1.75
G	TMV+p	MT20	2.0	4.0		
I	BMVW1-t	MT20	4.0	6.0	2.00	2.25
J	BMWW-t	MT20	4.0	4.0		
K	BS-t	MT20	3.0	6.0		
L	BMWWW-t	MT20	5.0	6.0		
M	BS-t	MT20	3.0	6.0		
N	BMWW-t	MT20	4.0	4.0		
O	BMVW1-t	MT20	4.0	6.0	2.00	2.25

LATERAL BRACE(S) SHOWN SHALL BE 2X4 SPF#2



**DIMENSIONS, SUPPORTS AND LOADINGS SPECIFIED BY FABRICATOR TO BE VERIFIED BY BUILDING DESIGNER**

**BEARINGS**

JT	FACTORED GROSS REACTION		MAXIMUM FACTORED GROSS REACTION		INPUT BRG	REQRD IN-SX
	VERT	HORZ	DOWN	HORZ		
O	1644	0	1644	0	5-8	1-12
I	1644	0	1644	0	5-8	1-12

**UNFACTORED REACTIONS**

JT	1ST LCASE		MAX./MIN. COMPONENT REACTIONS		WIND	DEAD	SOIL
	COMBINED	SNOW	LIVE	PERM.LIVE			
O	1172	715/0	0/0	0/0	0/0	457/0	0/0
I	1172	715/0	0/0	0/0	0/0	457/0	0/0

BEARING MATERIAL TO BE SPF NO.2 OR BETTER AT JOINT(S) O, I

**BRACING**  
 TOP CHORD TO BE SHEATHED OR MAX. PURLIN SPACING = 4.88 FT.  
 MAX. UNBRACED BOTTOM CHORD LENGTH = 10.00 FT OR RIGID CEILING DIRECTLY APPLIED.

ALL PITCH BREAKS AND PERIMETER CORNER JOINTS MUST BE LATERALLY RESTRAINED.  
 1 LATERAL BRACE(S) AT 1/2 LENGTH OF B-O, F-I.

END VERTICAL(S) MUST BE SHEATHED OR HAVE BRACES AS INDICATED IN THE MAX. UNBRACED LENGTH COLUMN OF THE TABLE BELOW

**LOADING**  
 TOTAL LOAD CASES: (4)

MEMB.	C H O R D S				W E B S			
	MAX. FACTORED FORCE (LBS)	FACTORED VERT. LOAD (PLF)	LC1 MAX (CSI)(LC)	UNBRACED LENGTH (FR-TO)	MAX. MEMB. FORCE (LBS)	FACTORED MAX (CSI)(LC)	UNBRACED LENGTH (FR-TO)	MAX. MEMB. FORCE (LBS)
A-B	0/24	-78.0	-78.0	0.30 (1)	10.00	B-N	-176/0	0.14 (1)
B-C	-1662/0	-78.0	-78.0	0.27 (1)	4.89	N-C	0/307	0.08 (4)
C-D	-1579/0	-78.0	-78.0	0.35 (1)	4.88	C-L	0/356	0.08 (1)
D-E	-1579/0	-78.0	-78.0	0.35 (1)	4.88	L-D	-536/0	0.61 (1)
E-F	-1662/0	-78.0	-78.0	0.27 (1)	4.89	L-E	0/356	0.08 (1)
F-G	0/24	-78.0	-78.0	0.30 (1)	10.00	J-E	0/307	0.08 (4)
O-A	-148/0	0.0	0.0	0.02 (1)	7.81	J-F	-176/0	0.14 (1)
I-G	-148/0	0.0	0.0	0.02 (1)	7.81	O-B	-1964/0	0.56 (1)
						F-I	-1964/0	0.56 (1)
P-O	0/0	-96.5	-96.5	0.16 (1)	10.00			
O-N	0/1496	-18.5	-18.5	0.54 (4)	10.00			
N-M	0/1365	-18.5	-18.5	0.54 (4)	10.00			
M-L	0/1365	-18.5	-18.5	0.54 (4)	10.00			
L-K	0/1365	-18.5	-18.5	0.54 (4)	10.00			
K-J	0/1365	-18.5	-18.5	0.54 (4)	10.00			
J-I	0/1496	-18.5	-18.5	0.54 (4)	10.00			
I-H	0/0	-96.5	-96.5	0.16 (1)	10.00			

**DESIGN CRITERIA**

**SPECIFIED LOADS:**

TOP CH.	LL	DL	PSF
		21.0	PSF
		6.0	PSF
BOT CH. <td>LL</td> <td>0.0</td> <td>PSF</td>	LL	0.0	PSF
	DL	7.4	PSF
TOTAL LOAD		34.4	PSF

**SPACING = 24.0 IN./C**

LOADING IN FLAT SECTION BASED ON A SLOPE OF 2.00/12 MINIMUM

THIS TRUSS IS DESIGNED FOR RESIDENTIAL OR SMALL BUILDING REQUIREMENTS OF PART 9, NBC 2015

THIS DESIGN COMPLIES WITH:  
 - PART 9 OF CBC 2018, ABC 2019  
 - PART 9 OF OBC 2012 (2019 AMENDMENT)  
 - CSA 086-14  
 - TPIC 2014

(55% OF 23.0 P.S.F. G.S.L. PLUS 8.4 P.S.F. RAIN LOAD) EQUALS 21.0 P.S.F. SPECIFIED ROOF LIVE LOAD

ALLOWABLE DEFL.(LL)= L/360 (1.03")  
 CALCULATED VERT. DEFL.(LL) = L/999 (0.07")  
 ALLOWABLE DEFL.(TL)= L/360 (1.03")  
 CALCULATED VERT. DEFL.(TL) = L/999 (0.31")

CANTILEVER DEFLECTION:  
 ALLOWABLE DEFL.(LL)= L/120 (0.19")  
 CALCULATED VERT. DEFL.(LL) = L/999 (0.01")  
 ALLOWABLE DEFL.(TL)= L/120 (0.19")  
 CALCULATED VERT. DEFL.(TL) = L/999 (0.01")

CSI: TC=0.35/1.00 (C-D:1), BC=0.54/1.00 (J-L:4), WB=0.61/1.00 (D-L:1), SSI=0.21/1.00 (C-D:1)

DOL LUMBER=1.00 NAIL=1.00 LS BEND=1.10 COMP=1.10 SHEAR=1.10 TENS= 1.10

COMPANION LIVE LOAD FACTOR = 1.00

TRUSS PLATE MANUFACTURER IS NOT RESPONSIBLE FOR QUALITY CONTROL IN THE TRUSS MANUFACTURING PLANT.

**NAIL VALUES**

PLATE	GRIP(DRY)	SHEAR (PSI)	SECTION (PLI)
MT20	650	371	1747 788 1987 1873

PLATE PLACEMENT TOL. = 0.250 inches

PLATE ROTATION TOL. = 5.0 Deg.

JSI GRIP= 0.89 (B) (INPUT = 0.90)  
 JSI METAL= 0.65 (F) (INPUT = 1.00)

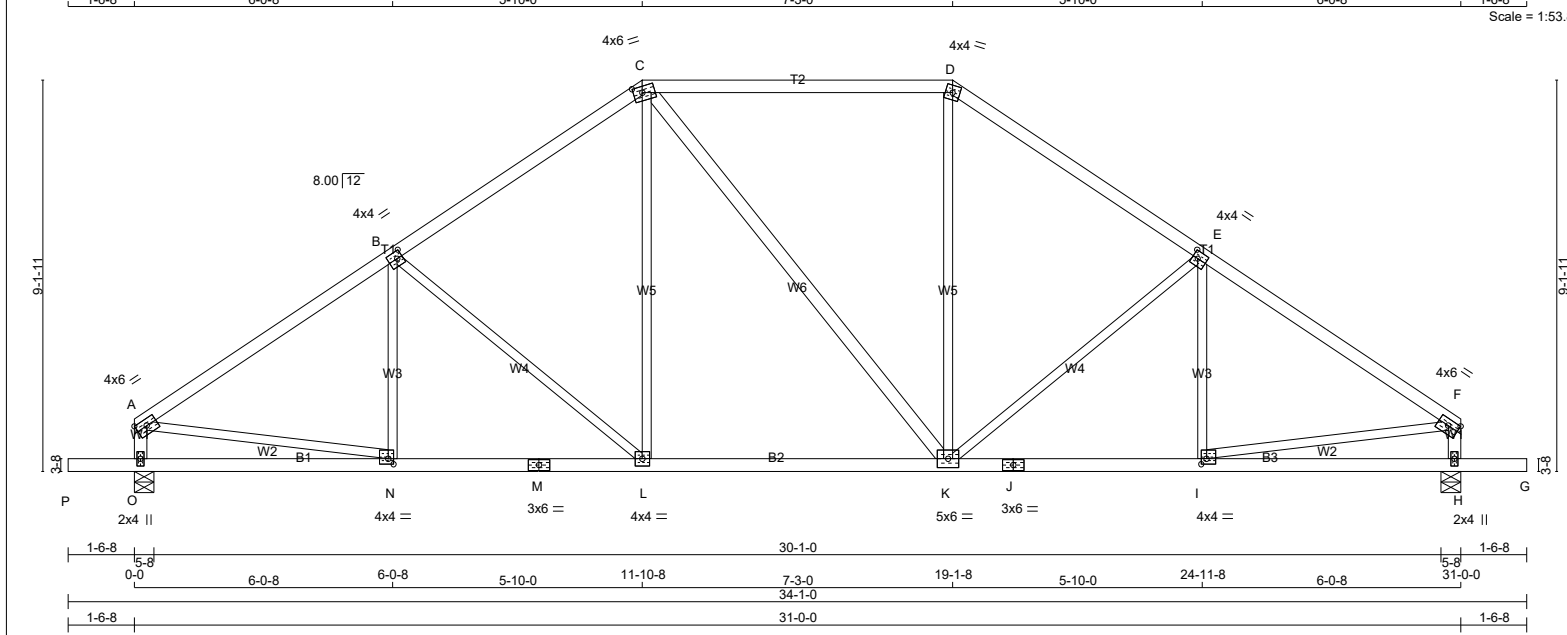

TOTAL WEIGHT = 137 lb [M][F]

**LUMBER**

N. L. G. A. RULES	CHORDS	SIZE	LUMBER	DESCR.
A - C	2x4	DRY	No.2	SPF
C - D	2x4	DRY	2100F 1.8E	SPF
D - F	2x4	DRY	No.2	SPF
O - A	2x4	DRY	No.2	SPF
H - F	2x4	DRY	No.2	SPF
P - M	2x4	DRY	No.2	SPF
M - J	2x4	DRY	No.2	SPF
J - G	2x4	DRY	No.2	SPF
ALL WEBS EXCEPT C - K	2x3	DRY	No.2	SPF

DRY: SEASONED LUMBER.

**PLATES (table is in inches)**

JT	TYPE	PLATES	W	LEN	Y	X
A	TMVW-t	MT20	4.0	6.0	1.75	Edge
B	TMWW-t	MT20	4.0	4.0	2.00	1.50
C	TTWW-m	MT20	4.0	6.0	1.75	2.50
D	TTW-m	MT20	4.0	4.0		
E	TMWW-t	MT20	4.0	4.0	2.00	1.50
F	TMVW-t	MT20	4.0	6.0	1.75	Edge
H	BMV1+p	MT20	2.0	4.0		
I	BMWW-t	MT20	4.0	4.0	1.50	1.50
J	BS-t	MT20	3.0	6.0		
K	BMWWW-t	MT20	5.0	6.0		
L	BMWW-t	MT20	4.0	4.0		
M	BS-t	MT20	3.0	6.0		
N	BMWW-t	MT20	4.0	4.0	1.50	1.50
O	BMV1+p	MT20	2.0	4.0		

Edge - INDICATES REFERENCE CORNER OF PLATE TOUCHES EDGE OF CHORD.

LATERAL BRACE(S) SHOWN SHALL BE 2X4 SPF#2



**DIMENSIONS, SUPPORTS AND LOADINGS SPECIFIED BY FABRICATOR TO BE VERIFIED BY BUILDING DESIGNER**

**BEARINGS**

	FACTORED GROSS REACTION	MAXIMUM FACTORED GROSS REACTION	INPUT BRG	REQRD BRG
JT	VERT	HORZ	DOWN	HORZ
O	1644	0	1644	0
H	1644	0	1644	0

**UNFACTORED REACTIONS**

JT	COMBINED	SNOW	LIVE	PERM.LIVE	WIND	DEAD	SOIL
O	1172	715 / 0	0 / 0	0 / 0	0 / 0	457 / 0	0 / 0
H	1172	715 / 0	0 / 0	0 / 0	0 / 0	457 / 0	0 / 0

BEARING MATERIAL TO BE SPF NO.2 OR BETTER AT JOINT(S) O, H

**BRACING**  
 TOP CHORD TO BE SHEATHED OR MAX. PURLIN SPACING = 4.52 FT.  
 MAX. UNBRACED BOTTOM CHORD LENGTH = 10.00 FT OR RIGID CEILING DIRECTLY APPLIED.

ALL PITCH BREAKS AND PERIMETER CORNER JOINTS MUST BE LATERALLY RESTRAINED.

**LOADING**  
 TOTAL LOAD CASES: (4)

CHORDS				WEBS			
MEMB.	FORCE (LBS)	FACTORED VERT. LOAD (PLF)	MAX LC1 (LC)	MAX. UNBRAC LENGTH	MEMB.	FORCE (LBS)	MAX FACTORED CSI (LC)
A-B	-1835 / 0	-78.0	-78.0 0.44 (1)	4.52	N-B	-115 / 45	0.05 (1)
B-C	-1528 / 0	-78.0	-78.0 0.40 (1)	4.90	B-L	-401 / 0	0.49 (1)
C-D	-1249 / 0	-78.0	-78.0 0.36 (1)	6.25	L-C	0 / 378	0.09 (1)
D-E	-1528 / 0	-78.0	-78.0 0.40 (1)	4.90	C-K	0 / 0	0.00 (1)
E-F	-1835 / 0	-78.0	-78.0 0.44 (1)	4.52	K-D	0 / 379	0.09 (1)
O-A	-1448 / 0	0.0	0.0 0.15 (1)	6.79	K-E	-400 / 0	0.49 (1)
H-F	-1448 / 0	0.0	0.0 0.15 (1)	6.79	I-E	-116 / 44	0.05 (1)
P-O	0 / 0	-96.5	-96.5 0.16 (1)	10.00	A-N	0 / 1570	0.35 (1)
O-N	0 / 0	-18.5	-18.5 0.14 (4)	10.00	I-F	0 / 1569	0.35 (1)
N-M	0 / 1552	-18.5	-18.5 0.34 (1)	10.00			
M-L	0 / 1552	-18.5	-18.5 0.34 (1)	10.00			
L-K	0 / 1248	-18.5	-18.5 0.29 (1)	10.00			
K-J	0 / 1552	-18.5	-18.5 0.34 (1)	10.00			
J-I	0 / 1552	-18.5	-18.5 0.34 (1)	10.00			
I-H	0 / 0	-18.5	-18.5 0.14 (4)	10.00			
H-G	0 / 0	-96.5	-96.5 0.16 (1)	10.00			

**DESIGN CRITERIA**

**SPECIFIED LOADS:**

TOP CH.	LL	DL	PSF
	LL	21.0	PSF
	DL	6.0	PSF
BOT CH.	LL	0.0	PSF
	DL	7.4	PSF
TOTAL LOAD		34.4	PSF

**SPACING = 24.0 IN./C/C**

LOADING IN FLAT SECTION BASED ON A SLOPE OF 2.00/12 MINIMUM

THIS TRUSS IS DESIGNED FOR RESIDENTIAL OR SMALL BUILDING REQUIREMENTS OF PART 9, NBC 2015

THIS DESIGN COMPLIES WITH:  
 - PART 9 OF CBC 2018, ABC 2019  
 - PART 9 OF OBC 2012 (2019 AMENDMENT)  
 - CSA 086-14  
 - TPIC 2014

(55% OF 23.0 P.S.F. G.S.L. PLUS 8.4 P.S.F. RAIN LOAD) EQUALS 21.0 P.S.F. SPECIFIED ROOF LIVE LOAD

ALLOWABLE DEFL.(LL)= L/360 (1.03")  
 CALCULATED VERT. DEFL.(LL) = L/999 (0.06")  
 ALLOWABLE DEFL.(TL)= L/360 (1.03")  
 CALCULATED VERT. DEFL.(TL) = L/999 (0.15")

**CANTILEVER DEFLECTION:**  
 ALLOWABLE DEFL.(LL)= L/120 (0.19")  
 CALCULATED VERT. DEFL.(LL) = L/999 (0.01")  
 ALLOWABLE DEFL.(TL)= L/120 (0.19")  
 CALCULATED VERT. DEFL.(TL) = L/999 (0.01")

CSI: TC=0.44/1.00 (A-B:1), BC=0.34/1.00 (I-K:1), WB=0.49/1.00 (B-L:1), SSI=0.22/1.00 (C-D:1)

DOL LUMBER=1.00 NAIL=1.00 LBS BEND=1.10 COMP=1.10 SHEAR=1.10 TENS= 1.10

COMPANION LIVE LOAD FACTOR = 1.00

TRUSS PLATE MANUFACTURER IS NOT RESPONSIBLE FOR QUALITY CONTROL IN THE TRUSS MANUFACTURING PLANT.

**NAIL VALUES**

PLATE	GRIP(DRY)	SHEAR (PSI)	SECTION (PLI)
MT20	650	371	1747 788 1987 1873

PLATE PLACEMENT TOL. = 0.250 inches  
 PLATE ROTATION TOL. = 5.0 Deg.

JSI GRIP= 0.85 (N) (INPUT = 0.90)  
 JSI METAL= 0.53 (N) (INPUT = 1.00)



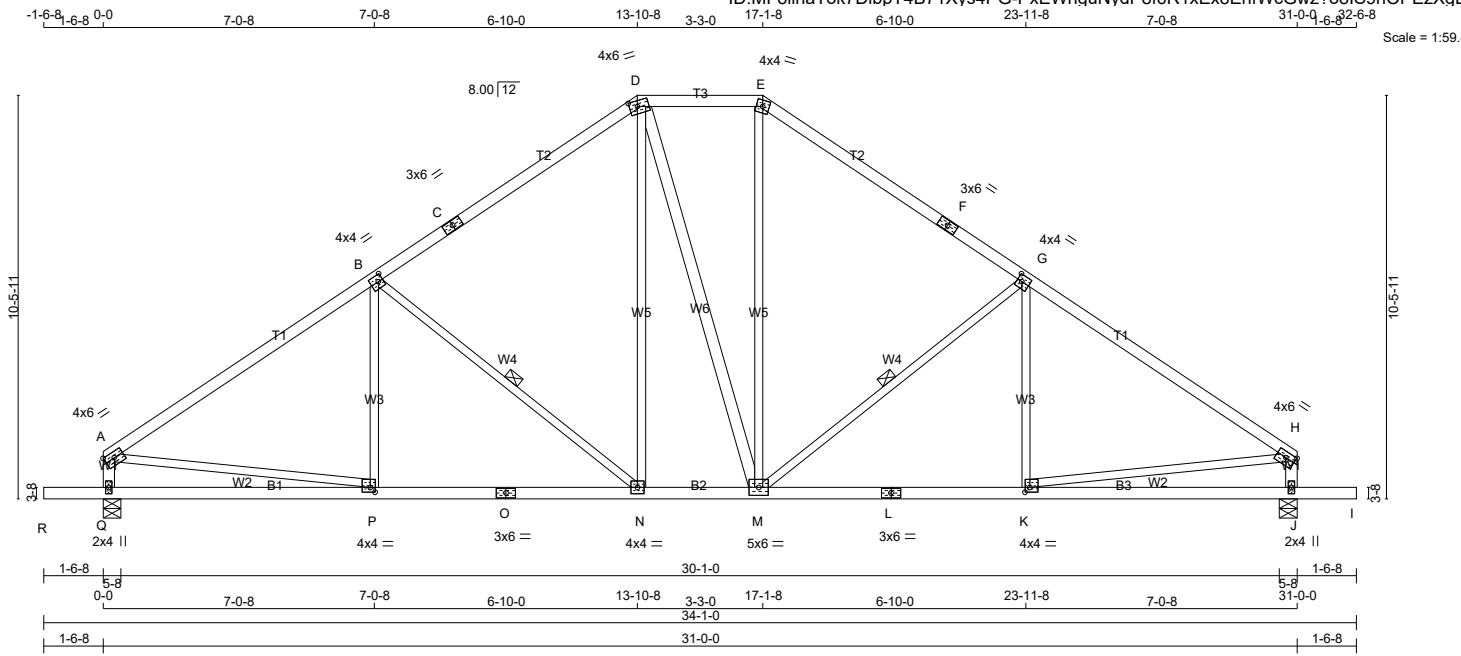

**LUMBER**

N. L. G. A. RULES	CHORDS	SIZE	LUMBER	DESCR.
A - C	2x4	DRY	No.2	SPF
C - D	2x4	DRY	No.2	SPF
D - E	2x4	DRY	No.2	SPF
E - F	2x4	DRY	No.2	SPF
F - H	2x4	DRY	No.2	SPF
Q - A	2x4	DRY	No.2	SPF
J - H	2x4	DRY	No.2	SPF
R - O	2x4	DRY	No.2	SPF
O - L	2x4	DRY	No.2	SPF
L - I	2x4	DRY	No.2	SPF
ALL WEBS EXCEPT D - M	2x3	DRY	No.2	SPF

DRY: SEASONED LUMBER.

**PLATES (table is in inches)**

JT	TYPE	PLATES	W	LEN	Y	X
A	TMVW-t	MT20	4.0	6.0	1.75	Edge
B	TMWW-t	MT20	4.0	4.0	2.00	1.50
C	TS-t	MT20	3.0	6.0		
D	TTWW-m	MT20	4.0	6.0	1.75	2.50
E	TTW-m	MT20	4.0	4.0		
F	TS-t	MT20	3.0	6.0		
G	TMWW-t	MT20	4.0	4.0	2.00	1.50
H	TMVW-t	MT20	4.0	6.0	1.75	Edge
J	BMV1+p	MT20	2.0	4.0		
K	BMWW-t	MT20	4.0	4.0	1.50	1.50
L	BS-t	MT20	3.0	6.0		
M	BMWWW-t	MT20	5.0	6.0		
N	BMWW-t	MT20	4.0	4.0		
O	BS-t	MT20	3.0	6.0		
P	BMWW-t	MT20	4.0	4.0	1.50	1.50
Q	BMV1+p	MT20	2.0	4.0		

Edge - INDICATES REFERENCE CORNER OF PLATE TOUCHES EDGE OF CHORD.

LATERAL BRACE(S) SHOWN SHALL BE 2X4 SPF#2



**DIMENSIONS, SUPPORTS AND LOADINGS SPECIFIED BY FABRICATOR TO BE VERIFIED BY BUILDING DESIGNER**

**BEARINGS**

JT	FACTORED GROSS REACTION		MAXIMUM FACTORED GROSS REACTION		INPUT BRG	REQRD BRG
	VERT	HORZ	DOWN	HORZ		
Q	1644	0	1644	0	5-8	2-7
J	1644	0	1644	0	5-8	2-7

**UNFACTORED REACTIONS**

JT	1ST LCASE COMBINED		MAX./MIN. COMPONENT REACTIONS				DEAD	SOIL
	SNOW	LIVE	PERM.LIVE	WIND	WIND	SOIL		
Q	1172	715 / 0	0 / 0	0 / 0	0 / 0	457 / 0	0 / 0	
J	1172	715 / 0	0 / 0	0 / 0	0 / 0	457 / 0	0 / 0	

BEARING MATERIAL TO BE SPF NO.2 OR BETTER AT JOINT(S) Q, J

**BRACING**  
 TOP CHORD TO BE SHEATHED OR MAX. PURLIN SPACING = 4.28 FT.  
 MAX. UNBRACED BOTTOM CHORD LENGTH = 10.00 FT OR RIGID CEILING DIRECTLY APPLIED.  
 ALL PITCH BREAKS AND PERIMETER CORNER JOINTS MUST BE Laterally RESTRAINED.

1 LATERAL BRACE(S) AT 1/2 LENGTH OF B-N, G-M.  
 END VERTICAL(S) MUST BE SHEATHED OR HAVE BRACES AS INDICATED IN THE MAX. UNBRACED LENGTH COLUMN OF THE TABLE BELOW

**LOADING**  
 TOTAL LOAD CASES: (4)

MEMB.	CHORDS			UNBRAC LENGTH	WEBS		
	MAX. FACTORED FORCE (LBS)	FACTORED VERT. LOAD (PLF)	FACTORED LC1 MAX CSI (LC)		MAX. MEMB. FORCE (LBS)	FACTORED FORCE (LBS)	MAX CSI (LC)
FR-TO		FROM	TO	FR-TO			
A-B	-1829 / 0	-78.0	-78.0 0.62 (1)	4.28	P-B	-50 / 92 0.03 (4)	
B-C	-1393 / 0	-78.0	-78.0 0.56 (1)	4.83	B-N	-546 / 0 0.30 (1)	
C-D	-1393 / 0	-78.0	-78.0 0.56 (1)	4.83	N-D	0 / 424 0.10 (1)	
D-E	-1132 / 0	-78.0	-78.0 0.12 (1)	5.85	D-M	0 / 4 0.00 (1)	
E-F	-1394 / 0	-78.0	-78.0 0.56 (1)	4.83	M-E	0 / 428 0.10 (1)	
F-G	-1394 / 0	-78.0	-78.0 0.56 (1)	4.83	M-G	-544 / 0 0.30 (1)	
G-H	-1828 / 0	-78.0	-78.0 0.62 (1)	4.28	K-G	-52 / 91 0.03 (4)	
Q-A	-1443 / 0	0.0	0.0 0.15 (1)	6.81	A-P	0 / 1564 0.35 (1)	
J-H	-1442 / 0	0.0	0.0 0.15 (1)	6.81	K-H	0 / 1564 0.35 (1)	
R-Q	0 / 0	-96.5	-96.5 0.16 (1)	10.00			
Q-P	0 / 0	-18.5	-18.5 0.23 (4)	10.00			
P-O	0 / 1552	-18.5	-18.5 0.38 (4)	10.00			
O-N	0 / 1552	-18.5	-18.5 0.38 (4)	10.00			
N-M	0 / 1131	-18.5	-18.5 0.25 (1)	10.00			
M-L	0 / 1551	-18.5	-18.5 0.37 (4)	10.00			
L-K	0 / 1551	-18.5	-18.5 0.37 (4)	10.00			
K-J	0 / 0	-18.5	-18.5 0.23 (4)	10.00			
J-I	0 / 0	-96.5	-96.5 0.16 (1)	10.00			

**DESIGN CRITERIA**

**SPECIFIED LOADS:**  
 TOP CH. LL = 21.0 PSF  
 DL = 6.0 PSF  
 BOT CH. LL = 0.0 PSF  
 DL = 7.4 PSF  
 TOTAL LOAD = 34.4 PSF

**SPACING = 24.0 IN./C/C**

LOADING IN FLAT SECTION BASED ON A SLOPE OF 2.00/12 MINIMUM

THIS TRUSS IS DESIGNED FOR RESIDENTIAL OR SMALL BUILDING REQUIREMENTS OF PART 9, NBC 2015

THIS DESIGN COMPLIES WITH:  
 - PART 9 OF BCBC 2018, ABC 2019  
 - PART 9 OF OBC 2012 (2019 AMENDMENT)  
 - CSA 086-14  
 - TPIC 2014

(55% OF 23.0 P.S.F. G.S.L. PLUS 8.4 P.S.F. RAIN LOAD) EQUALS 21.0 P.S.F. SPECIFIED ROOF LIVE LOAD

ALLOWABLE DEFL.(LL)= L/360 (1.03")  
 CALCULATED VERT. DEFL.(LL) = L/999 (0.07")  
 ALLOWABLE DEFL.(TL)= L/360 (1.03")  
 CALCULATED VERT. DEFL.(TL) = L/999 (0.15")

CANTILEVER DEFLECTION:  
 ALLOWABLE DEFL.(LL)= L/120 (0.19")  
 CALCULATED VERT. DEFL.(LL) = L/999 (0.01")  
 ALLOWABLE DEFL.(TL)= L/120 (0.19")  
 CALCULATED VERT. DEFL.(TL) = L/999 (0.01")

CSI: TC=0.62/1.00 (A-B:1), BC=0.38/1.00 (N-P:4), WB=0.35/1.00 (A-P:1), SS=0.22/1.00 (A-B:1)

DOL LUMBER=1.00 NAIL=1.00 LBS BEND=1.10 COMP=1.10 SHEAR=1.10 TENS= 1.10

COMPANION LIVE LOAD FACTOR = 1.00

TRUSS PLATE MANUFACTURER IS NOT RESPONSIBLE FOR QUALITY CONTROL IN THE TRUSS MANUFACTURING PLANT.

**NAIL VALUES**

PLATE	GRIP (DRY)	SHEAR (PSI)	SECTION (PLI)
MT20	650	371	1747
	788	1987	1873

PLATE PLACEMENT TOL. = 0.250 inches

PLATE ROTATION TOL. = 5.0 Deg.

JSI GRIP= 0.83 (P) (INPUT = 0.90)  
 JSI METAL= 0.56 (O) (INPUT = 1.00)

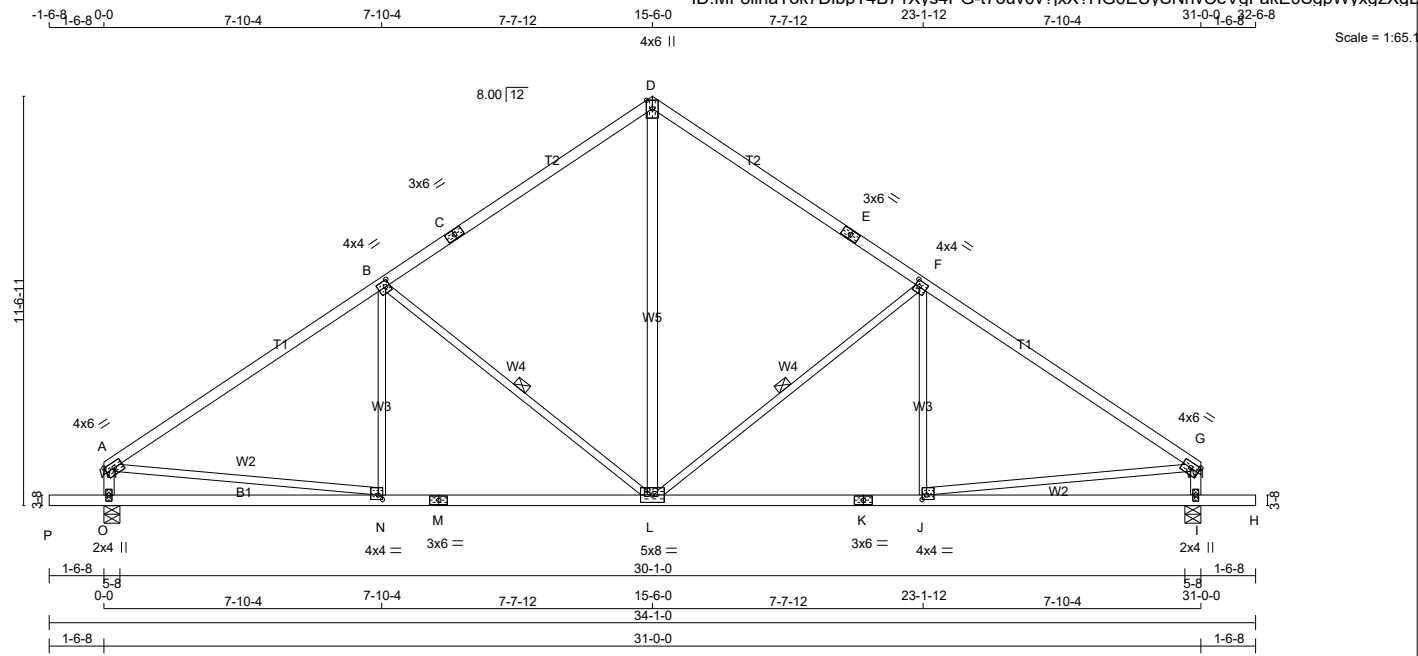

TOTAL WEIGHT = 133 lb

**LUMBER**

N. L. G. A. RULES	CHORDS	SIZE	LUMBER	DESCR.
A - C	2x4	DRY	No.2	SPF
C - D	2x4	DRY	No.2	SPF
D - E	2x4	DRY	No.2	SPF
E - G	2x4	DRY	No.2	SPF
O - A	2x4	DRY	No.2	SPF
I - G	2x4	DRY	No.2	SPF
P - M	2x4	DRY	No.2	SPF
M - K	2x4	DRY	No.2	SPF
K - H	2x4	DRY	No.2	SPF
ALL WEBS EXCEPT L - D	2x3	DRY	No.2	SPF

DRY: SEASONED LUMBER.

**PLATES (table is in inches)**

JT	TYPE	PLATES	W	LEN	Y	X
A	TMVW-t	MT20	4.0	6.0	1.75	Edge
B	TMWW-t	MT20	4.0	4.0	2.00	1.50
C	TS-t	MT20	3.0	6.0		
D	TTW+p	MT20	4.0	6.0		Edge
E	TS-t	MT20	3.0	6.0		
F	TMWW-t	MT20	4.0	4.0	2.00	1.50
G	TMVW-t	MT20	4.0	6.0	1.75	Edge
I	BMV1+p	MT20	2.0	4.0		
J	BMWW-t	MT20	4.0	4.0	1.50	1.50
K	BS-t	MT20	3.0	6.0		
L	BMWWW-t	MT20	5.0	8.0		
M	BS-t	MT20	3.0	6.0		
N	BMWW-t	MT20	4.0	4.0	1.50	1.50
O	BMV1+p	MT20	2.0	4.0		

Edge - INDICATES REFERENCE CORNER OF PLATE TOUCHES EDGE OF CHORD.

LATERAL BRACE(S) SHOWN SHALL BE 2X4 SPF#2

**DIMENSIONS, SUPPORTS AND LOADINGS SPECIFIED BY FABRICATOR TO BE VERIFIED BY BUILDING DESIGNER**

**BEARINGS**

JT	FACTORED GROSS REACTION		MAXIMUM FACTORED GROSS REACTION		INPUT BRG	REQRD BRG
	VERT	HORZ	DOWN	HORZ		
O	1644	0	1644	0	5-8	2-7
I	1644	0	1644	0	5-8	2-7

**UNFACTORED REACTIONS**

JT	1ST LCASE		MAX./MIN. COMPONENT REACTIONS				WIND	DEAD	SOIL
	COMBINED	SNOW	LIVE	PERM.LIVE	WIND	DEAD			
O	1172	715 / 0	0 / 0	0 / 0	0 / 0	0 / 0	457 / 0	0 / 0	
I	1172	715 / 0	0 / 0	0 / 0	0 / 0	0 / 0	457 / 0	0 / 0	

BEARING MATERIAL TO BE SPF NO.2 OR BETTER AT JOINT(S) O, I

**BRACING**  
 TOP CHORD TO BE SHEATHED OR MAX. PURLIN SPACING = 4.00 FT.  
 MAX. UNBRACED BOTTOM CHORD LENGTH = 10.00 FT OR RIGID CEILING DIRECTLY APPLIED.

ALL PITCH BREAKS AND PERIMETER CORNER JOINTS MUST BE Laterally RESTRAINED.

1 LATERAL BRACE(S) AT 1/2 LENGTH OF F-L, B-L.

END VERTICAL(S) MUST BE SHEATHED OR HAVE BRACES AS INDICATED IN THE MAX. UNBRACED LENGTH COLUMN OF THE TABLE BELOW

**LOADING**  
 TOTAL LOAD CASES: (4)

FR-TO	CHORDS			WEBS		
	MEMB. FORCE (LBS)	FACTORED VERT. LOAD (PLF)	FACTORED VERT. LOAD LC1 MAX (CSI(LC))	MEMB. FORCE (LBS)	FACTORED VERT. LOAD (PLF)	FACTORED VERT. LOAD LC1 MAX (CSI(LC))
A-B	-1809 / 0	-78.0	-78.0 0.81 (1)	4.00	L-D	0 / 938 0.15 (1)
B-C	-1290 / 0	-78.0	-78.0 0.70 (1)	4.69	L-F	-642 / 0 0.44 (1)
C-D	-1290 / 0	-78.0	-78.0 0.70 (1)	4.69	J-F	-17 / 114 0.04 (4)
D-E	-1290 / 0	-78.0	-78.0 0.70 (1)	4.69	B-L	-642 / 0 0.44 (1)
E-F	-1290 / 0	-78.0	-78.0 0.70 (1)	4.69	N-B	-17 / 114 0.04 (4)
F-G	-1809 / 0	-78.0	-78.0 0.81 (1)	4.00	A-N	0 / 1549 0.35 (1)
O-A	-1436 / 0	0.0	0.0 0.15 (1)	6.81	J-G	0 / 1549 0.35 (1)
I-G	-1436 / 0	0.0	0.0 0.15 (1)	6.81		
P-O	0 / 0	-96.5	-96.5 0.16 (1)	10.00		
O-N	0 / 0	-18.5	-18.5 0.27 (4)	10.00		
N-M	0 / 1539	-18.5	-18.5 0.42 (4)	10.00		
M-L	0 / 1539	-18.5	-18.5 0.42 (4)	10.00		
L-K	0 / 1539	-18.5	-18.5 0.42 (4)	10.00		
K-J	0 / 1539	-18.5	-18.5 0.42 (4)	10.00		
J-I	0 / 0	-18.5	-18.5 0.27 (4)	10.00		
I-H	0 / 0	-96.5	-96.5 0.16 (1)	10.00		

**DESIGN CRITERIA**

**SPECIFIED LOADS:**

TOP CH.	LL = 21.0 PSF
	DL = 6.0 PSF
BOT CH.	LL = 0.0 PSF
	DL = 7.4 PSF
TOTAL LOAD	= 34.4 PSF

**SPACING = 24.0 IN./C/C**

THIS TRUSS IS DESIGNED FOR RESIDENTIAL OR SMALL BUILDING REQUIREMENTS OF PART 9, NBC2015

THIS DESIGN COMPLIES WITH:  
 - PART 9 OF BCBC 2018 , ABC 2019  
 - PART 9 OF OBC 2012 (2019 AMENDMENT)  
 - CSA 086-14  
 - TPIC 2014

(55 % OF 23.0 P.S.F. G.S.L. PLUS 8.4 P.S.F. RAIN LOAD) EQUALS 21.0 P.S.F. SPECIFIED ROOF LIVE LOAD

ALLOWABLE DEFL.(LL)= L/360 (1.03")  
 CALCULATED VERT. DEFL.(LL) = L/ 999 (0.07")  
 ALLOWABLE DEFL.(TL)= L/360 (1.03")  
 CALCULATED VERT. DEFL.(TL) = L/ 999 (0.16")

**CANTILEVER DEFLECTION:**  
 ALLOWABLE DEFL.(LL)= L/120 (0.19")  
 CALCULATED VERT. DEFL.(LL) = L/ 999 (0.01")  
 ALLOWABLE DEFL.(TL)= L/120 (0.19")  
 CALCULATED VERT. DEFL.(TL) = L/ 999 (0.01")

CSI: TC=0.81/1.00 (F-G:1), BC=0.42/1.00 (J-L:4), WB=0.44/1.00 (F-L:1), SSI=0.25/1.00 (A-B:1)

DOL LUMBER=1.00 NAIL=1.00 LS BEND=1.10 COMP=1.10 SHEAR=1.10 TENS= 1.10

COMPANION LIVE LOAD FACTOR = 1.00

TRUSS PLATE MANUFACTURER IS NOT RESPONSIBLE FOR QUALITY CONTROL IN THE TRUSS MANUFACTURING PLANT .

**NAIL VALUES**

PLATE	GRIP(DRY)	SHEAR	SECTION
(PSI)	(PLI)	(PLI)	(PLI)
MAX MIN	MAX MIN	MAX MIN	MAX MIN
MT20	650 371	1747 788	1987 1873

PLATE PLACEMENT TOL. = 0.250 inches

PLATE ROTATION TOL. = 5.0 Deg.

JSI GRIP= 0.82 (J) (INPUT = 0.90)  
 JSI METAL= 0.52 (J) (INPUT = 1.00)



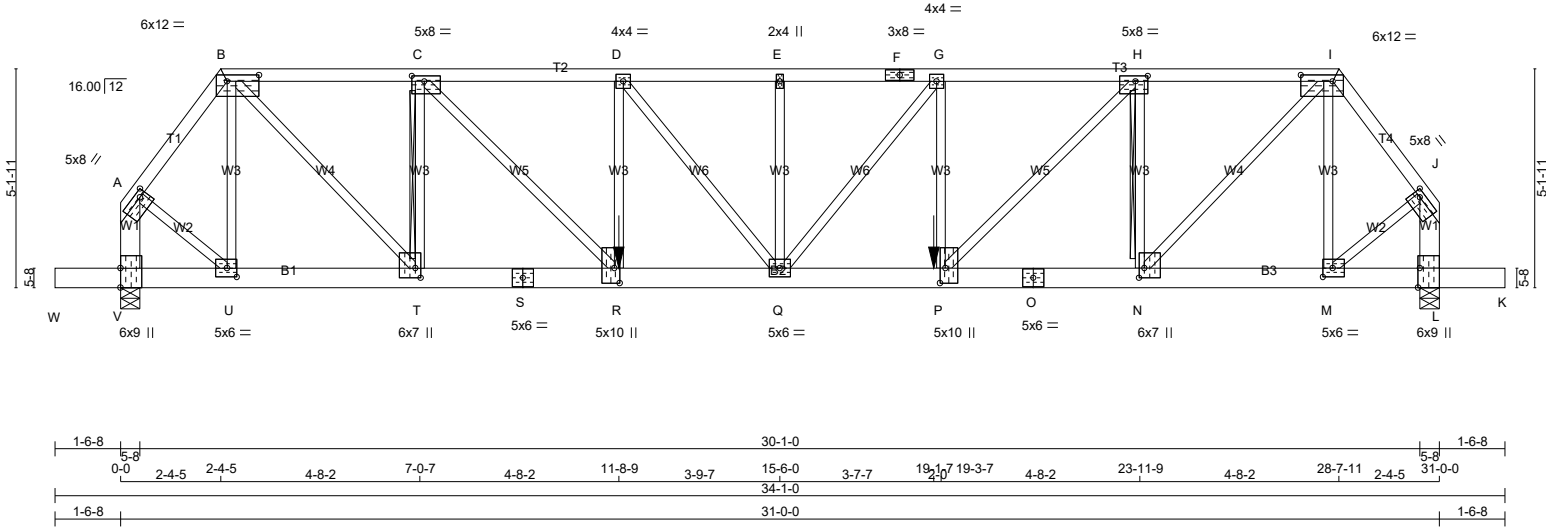
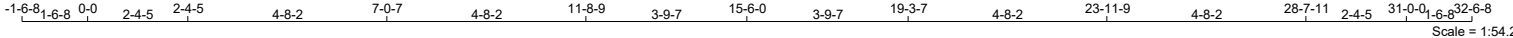

**LUMBER**

N. L. G. A. RULES	CHORDS	SIZE	LUMBER	DESCR.
A - B	2x4	DRY	No.2	SPF
B - F	2x4	DRY	1650F 1.5E	SPF
F - I	2x4	DRY	1650F 1.5E	SPF
I - J	2x4	DRY	No.2	SPF
V - A	2x6	DRY	No.2	SPF
L - J	2x6	DRY	No.2	SPF
W - S	2x6	DRY	1650F 1.5E	SPF
S - O	2x6	DRY	1650F 1.5E	SPF
O - K	2x6	DRY	1650F 1.5E	SPF
ALL WEBS EXCEPT	2x3	DRY	No.2	SPF

DRY: SEASONED LUMBER.

**PLATES (table is in inches)**

JT	TYPE	PLATES	W	LEN	Y	X
A	TMVW-t	MT20	5.0	8.0	1.50	2.00
B	TTWW-l	MT20	6.0	12.0	1.75	9.00
C	TMWW-t	MT20	5.0	8.0	1.50	3.50
D	TMWW-t	MT20	4.0	4.0		
E	TMW+w	MT20	2.0	4.0		
F	TS-t	MT20	3.0	8.0		
G	TMWW-t	MT20	4.0	4.0		
H	TMWW-t	MT20	5.0	8.0	1.50	3.50
I	TTWW-l	MT20	6.0	12.0	1.75	9.00
J	TMVW-t	MT20	5.0	8.0	1.50	2.00
L	BMV1-t	MT20	6.0	9.0	Edge	0.50
M	BMWW-t	MT20	5.0	6.0	2.50	2.75
N	BMWW-t	MT20	6.0	7.0	2.75	1.50
O	BS-t	MT20	5.0	6.0		
P	BMWW-t	MT20	5.0	10.0	4.25	1.50
Q	BMWW-t	MT20	5.0	6.0		
R	BMWW-t	MT20	5.0	10.0	4.25	1.50
S	BS-t	MT20	5.0	6.0		
T	BMWW-t	MT20	6.0	7.0	2.75	1.50
U	BMWW-t	MT20	5.0	6.0	2.50	2.75
V	BMV1-t	MT20	6.0	9.0	Edge	

Edge - INDICATES REFERENCE CORNER OF PLATE TOUCHES EDGE OF CHORD.

LATERAL BRACE(S) SHOWN SHALL BE 2X4 SPF#2



**DIMENSIONS, SUPPORTS AND LOADINGS SPECIFIED BY FABRICATOR TO BE VERIFIED BY BUILDING DESIGNER**

**BEARINGS**

JT	VERT	HORZ	GROSS REACTION	MAXIMUM FACTORED GROSS REACTION	INPUT BRG	REQRD BRG
V	3497	0	3497	0	0	5-8
L	3417	0	3417	0	0	5-8

**UNFACTORED REACTIONS**

JT	COMBINED	SNOW	LIVE	PERM.LIVE	WIND	DEAD	SOIL
V	2466	1658 / 0	0 / 0	0 / 0	0 / 0	809 / 0	0 / 0
L	2410	1615 / 0	0 / 0	0 / 0	0 / 0	795 / 0	0 / 0

BEARING MATERIAL TO BE SPF NO.2 OR BETTER AT JOINT(S) V, L BEARING SIZE FACTOR = 1.15 AT JNT(S) V (BASED ON SUPPORT DEPTH = 1-8)

**BRACING**  
TOP CHORD TO BE SHEATHED OR MAX. PURLIN SPACING = 2.66 FT. MAX. UNBRACED BOTTOM CHORD LENGTH = 10.00 FT OR RIGID CEILING DIRECTLY APPLIED.

ALL PITCH BREAKS AND PERIMETER CORNER JOINTS MUST BE LATERALLY RESTRAINED.

2x4 DRY SPF No.2 T-BRACE AT C-T, H-N

FASTEN T AND I-BRACES TO NARROW EDGE OF WEB WITH ONE ROW PER PLY OF 3" COMMON WIRE NAILS @ 6" O.C. WITH 3" MINIMUM END DISTANCE. BRACE MUST COVER 90% OF WEB LENGTH.

END VERTICAL(S) MUST BE SHEATHED OR HAVE BRACES AS INDICATED IN THE MAX. UNBRACED LENGTH COLUMN OF THE TABLE BELOW

**LOADING**

TOTAL LOAD CASES: (4)

MEMB.	CHORDS			WEBS			
	MAX. FORCE (LBS)	FACTORED VERT. LOAD (PLF)	FACTORED VERT. LOAD LC1 MAX CSI (LC)	MAX. UNBRACED LENGTH	MEMB. FORCE (LBS)	MAX. FACTORED VERT. LOAD LC1 MAX CSI (LC)	
FR-TO		FROM	TO	FR-TO			
A-B	-2848 / 0	-78.0	-78.0	0.21 (1)	3.93	U-B -859 / 0	0.32 (1)
B-C	-4475 / 0	-78.0	-78.0	0.37 (1)	3.56	B-T 0 / 4027	1.00 (1)
C-D	-6836 / 0	-78.0	-78.0	0.80 (1)	2.76	T-C -2809 / 0	0.61 (1)
D-E	-7058 / 0	-156.0	-156.0	0.59 (1)	2.66	C-R 0 / 3371	0.83 (1)
E-F	-7058 / 0	-156.0	-156.0	0.59 (1)	2.66	R-D -732 / 0	0.28 (1)
F-G	-7058 / 0	-156.0	-156.0	0.59 (1)	2.66	D-Q 0 / 357	0.09 (1)
G-H	-6642 / 0	-78.0	-78.0	0.58 (1)	2.82	Q-E -623 / 0	0.24 (1)
H-I	-4355 / 0	-78.0	-78.0	0.37 (1)	3.61	Q-G 0 / 668	0.17 (1)
I-J	-2777 / 0	-78.0	-78.0	0.20 (1)	3.98	P-G -977 / 0	0.37 (1)
V-A	-3370 / 0	0.0	0.0	0.27 (1)	5.74	P-H 0 / 3266	0.81 (1)
L-J	-3289 / 0	0.0	0.0	0.27 (1)	5.80	N-H -2734 / 0	0.60 (1)
						N-I 0 / 3914	0.97 (1)
W-V	0 / 0	-96.5	-96.5	0.06 (1)	10.00	M-I -834 / 0	0.32 (1)
V-U	0 / 0	-18.5	-18.5	0.06 (1)	10.00	A-U 0 / 1978	0.49 (1)
U-T	0 / 1677	-18.5	-18.5	0.20 (1)	10.00	M-J 0 / 1929	0.48 (1)
T-S	0 / 4475	-18.5	-18.5	0.44 (1)	10.00		
S-R	0 / 4475	-18.5	-18.5	0.44 (1)	10.00		
R-Q	0 / 6836	-37.3	-37.3	0.65 (1)	10.00		
Q-P	0 / 6642	-37.3	-37.3	0.62 (1)	10.00		
P-O	0 / 4355	-18.5	-18.5	0.42 (1)	10.00		
O-N	0 / 4355	-18.5	-18.5	0.42 (1)	10.00		
N-M	0 / 1635	-18.5	-18.5	0.19 (1)	10.00		
M-L	0 / 0	-18.5	-18.5	0.06 (1)	10.00		
L-K	0 / 0	-96.5	-96.5	0.06 (1)	10.00		

**FACTORED CONCENTRATED LOADS (LBS)**

JT	LOC.	LC1	MAX-	MAX+	FACE	DIR.	TYPE	HEEL	CONN.
P	19-1-7	-1281	-1281	---	FRONT	VERT	TOTAL	---	C1
R	11-8-9	-1612	-1612	---	FRONT	VERT	TOTAL	---	C1

**DESIGN CRITERIA**

\*\*\* SPECIAL LOADS ANALYSIS \*\*\*  
GEOMETRY AND/OR BASIC LOADS CHANGED BY USER.  
LOADS WERE DERIVED FROM USER INPUT NO FURTHER MODIFICATIONS WERE MADE

**SPECIFIED LOADS:**

TOP CH.	LL = 21.0 PSF
	DL = 6.0 PSF
BOT CH.	LL = 0.0 PSF
	DL = 7.4 PSF
TOTAL LOAD	= 34.4 PSF

**SPACING = 24.0 IN./C/C**

LOADING IN FLAT SECTION BASED ON A SLOPE OF 2.00/12 MINIMUM

\*\*\* NON STANDARD GIRDER \*\*\*  
ADDTL USER-DEFINED LOADS APPLIED TO ALL LOAD CASES.

THIS TRUSS IS DESIGNED FOR RESIDENTIAL OR SMALL BUILDING REQUIREMENTS OF PART 9, NBCC 2015

THIS DESIGN COMPLIES WITH:  
- PART 9 OF BCBC 2018, ABC 2019  
- PART 9 OF OBC 2012 (2019 AMENDMENT)  
- CSA 086-14  
- TPIC 2014

(55% OF 23.0 P.S.F. G.S.L. PLUS 8.4 P.S.F. RAIN LOAD) EQUALS 21.0 P.S.F. SPECIFIED ROOF LIVE LOAD

ALLOWABLE DEFL.(LL)=	L/360 (1.03")
CALCULATED VERT. DEFL.(LL)=	L/999 (0.30")
ALLOWABLE DEFL.(TL)=	L/360 (1.03")
CALCULATED VERT. DEFL.(TL)=	L/682 (0.55")

**CANTILEVER DEFLECTION:**  
ALLOWABLE DEFL.(LL)= L/120 (0.19")  
CALCULATED VERT. DEFL.(LL)= L/999 (0.00")  
ALLOWABLE DEFL.(TL)= L/120 (0.19")  
CALCULATED VERT. DEFL.(TL)= L/999 (0.00")

CSI: TC=0.60/1.00 (C-D:1), BC=0.65/1.00 (Q-R:1), WB=1.00/1.00 (B-T:1), SSI=0.27/1.00 (D-E:1)

DOL LUMBER=1.00 NAIL=1.00 LS BEND=1.00 COMP=1.00 SHEAR=1.00 TENS=1.00

COMPANION LIVE LOAD FACTOR = 1.00

AUTOSOLVE HEELS OFF

TRUSS PLATE MANUFACTURER IS NOT RESPONSIBLE FOR QUALITY CONTROL IN THE TRUSS MANUFACTURING PLANT.

**NAIL VALUES**

PLATE	GRIP(DRY)	SHEAR (PSI)	SECTION (PLI)	MAX MIN	MAX MIN	MAX MIN
MT20	650	371	1747	788	1987	1873

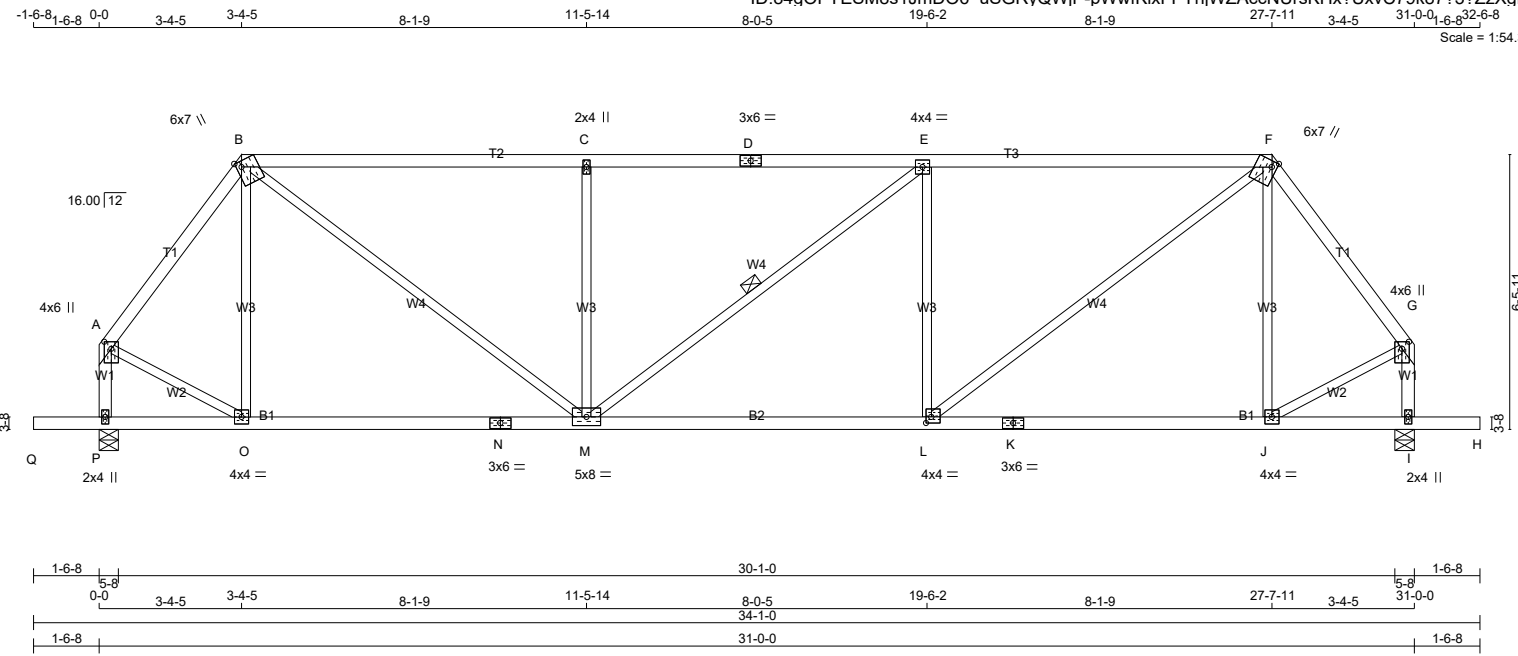

TOTAL WEIGHT = 2 X 133 = 265 lb

**LUMBER**

N. L. G. A. RULES	CHORDS	SIZE	LUMBER	DESCR.
A - B	2x4	DRY	No.2	SPF
B - D	2x4	DRY	No.2	SPF
D - F	2x4	DRY	No.2	SPF
F - G	2x4	DRY	No.2	SPF
P - A	2x4	DRY	No.2	SPF
I - G	2x4	DRY	No.2	SPF
Q - N	2x4	DRY	No.2	SPF
N - K	2x4	DRY	No.2	SPF
K - H	2x4	DRY	No.2	SPF
ALL WEBS EXCEPT	2x3	DRY	No.2	SPF

DRY: SEASONED LUMBER.

**PLATES (table is in inches)**

JT	TYPE	PLATES	W	LEN	Y	X
A	TMVW+p	MT20	4.0	6.0	2.00	2.00
B	TTWW+m	MT20	6.0	7.0	Edge	1.50
C	TMW+w	MT20	2.0	4.0		
D	TS-t	MT20	3.0	6.0		
E	TMWW-t	MT20	4.0	4.0		
F	TTWW+m	MT20	6.0	7.0	Edge	1.50
G	TMVW+p	MT20	4.0	6.0	2.00	2.00
I	BMV1+p	MT20	2.0	4.0		
J	BMWW-t	MT20	4.0	4.0		
K	BS-t	MT20	3.0	6.0		
L	BMWW-t	MT20	4.0	4.0	1.75	1.50
M	BMWWW-t	MT20	5.0	8.0		
N	BS-t	MT20	3.0	6.0		
O	BMWW-t	MT20	4.0	4.0		
P	BMV1+p	MT20	2.0	4.0		

Edge - INDICATES REFERENCE CORNER OF PLATE TOUCHES EDGE OF CHORD.

LATERAL BRACE(S) SHOWN SHALL BE 2X4 SPF#2



**DIMENSIONS, SUPPORTS AND LOADINGS SPECIFIED BY FABRICATOR TO BE VERIFIED BY BUILDING DESIGNER**

**BEARINGS**

JT	FACTORED GROSS REACTION		MAXIMUM FACTORED GROSS REACTION		INPUT BRG	REQRD BRG
	VERT	HORZ	DOWN	HORZ		
P	1644	0	1644	0	5-8	2-7
I	1644	0	1644	0	5-8	2-7

**UNFACTORED REACTIONS**

JT	COMBINED	MAX./MIN. COMPONENT REACTIONS				WIND	DEAD	SOIL
		1ST LCASE	SNOW	LIVE	PERM.LIVE			
P	1172	715/0	0/0	0/0	0/0	457/0	0/0	
I	1172	715/0	0/0	0/0	0/0	457/0	0/0	

BEARING MATERIAL TO BE SPF NO.2 OR BETTER AT JOINT(S) P, I

**BRACING**  
TOP CHORD TO BE SHEATHED OR MAX. PURLIN SPACING = 3.67 FT.  
MAX. UNBRACED BOTTOM CHORD LENGTH = 10.00 FT OR RIGID CEILING DIRECTLY APPLIED.

ALL PITCH BREAKS AND PERIMETER CORNER JOINTS MUST BE LATERALLY RESTRAINED.  
1 LATERAL BRACE(S) AT 1/2 LENGTH OF E-M.

END VERTICAL(S) MUST BE SHEATHED OR HAVE BRACES AS INDICATED IN THE MAX. UNBRACED LENGTH COLUMN OF THE TABLE BELOW

**LOADING**  
TOTAL LOAD CASES: (4)

MEMB.	C H O R D S				W E B S			
	MAX. FORCE (LBS)	FACTORED VERT. LOAD (PLF)	LC1 MAX (CSI(LC))	UNBRAC LENGTH	MEMB. FORCE (LBS)	MAX. FORCE (LBS)	FACTORED MAX (CSI(LC))	UNBRAC LENGTH
A-B	-1256/0	-78.0	-78.0	0.19 (1)	5.54	O-B	-219/2	0.15 (1)
B-C	-1844/0	-78.0	-78.0	0.99 (1)	3.69	B-M	0/1378	0.31 (1)
C-D	-1844/0	-78.0	-78.0	0.99 (1)	3.67	M-C	-680/0	0.46 (1)
D-E	-1844/0	-78.0	-78.0	0.99 (1)	3.67	M-E	-1/0	0.00 (1)
E-F	-1845/0	-78.0	-78.0	1.00 (1)	3.67	L-E	-680/0	0.46 (1)
F-G	-1256/0	-78.0	-78.0	0.19 (1)	5.54	L-F	0/1379	0.31 (1)
P-A	-1487/0	0.0	0.0	0.17 (1)	6.72	J-F	-219/2	0.15 (1)
I-G	-1486/0	0.0	0.0	0.17 (1)	6.72	A-O	0/825	0.19 (1)
Q-P	0/0	-96.5	-96.5	0.16 (1)	10.00	J-G	0/825	0.19 (1)
P-O	0/0	-18.5	-18.5	0.18 (4)	10.00			
O-N	0/745	-18.5	-18.5	0.31 (4)	10.00			
N-M	0/745	-18.5	-18.5	0.31 (4)	10.00			
M-L	0/1845	-18.5	-18.5	0.43 (1)	10.00			
L-K	0/744	-18.5	-18.5	0.31 (4)	10.00			
K-J	0/744	-18.5	-18.5	0.31 (4)	10.00			
J-I	0/0	-18.5	-18.5	0.18 (4)	10.00			
I-H	0/0	-96.5	-96.5	0.16 (1)	10.00			

**DESIGN CRITERIA**

**SPECIFIED LOADS:**  
TOP CH. LL = 21.0 PSF  
DL = 6.0 PSF  
BOT CH. LL = 0.0 PSF  
DL = 7.4 PSF  
TOTAL LOAD = 34.4 PSF

**SPACING = 24.0 IN./C**

LOADING IN FLAT SECTION BASED ON A SLOPE OF 2.00/12 MINIMUM

THIS TRUSS IS DESIGNED FOR RESIDENTIAL OR SMALL BUILDING REQUIREMENTS OF PART 9, NBC 2015

THIS DESIGN COMPLIES WITH:  
- PART 9 OF CBC 2018, ABC 2019  
- PART 9 OF OBC 2012 (2019 AMENDMENT)  
- CSA 086-14  
- TPIC 2014

(55% OF 23.0 P.S.F. G.S.L. PLUS 8.4 P.S.F. RAIN LOAD) EQUALS 21.0 P.S.F. SPECIFIED ROOF LIVE LOAD

ALLOWABLE DEFL.(LL)= L/360 (1.03")  
CALCULATED VERT. DEFL.(LL) = L/999 (0.08")  
ALLOWABLE DEFL.(TL)= L/360 (1.03")  
CALCULATED VERT. DEFL.(TL) = L/999 (0.19")

CANTILEVER DEFLECTION:  
ALLOWABLE DEFL.(LL)= L/120 (0.19")  
CALCULATED VERT. DEFL.(LL) = L/999 (0.01")  
ALLOWABLE DEFL.(TL)= L/120 (0.19")  
CALCULATED VERT. DEFL.(TL) = L/999 (0.01")

CSI: TC=1.00/1.00 (E-F:1), BC=0.43/1.00 (L-M:1), WB=0.46/1.00 (E-L:1), SSI=0.30/1.00 (E-F:1)

DOL LUMBER=1.00 NAIL=1.00 LS BEND=1.10 COMP=1.10 SHEAR=1.10 TENS=1.10

COMPANION LIVE LOAD FACTOR = 1.00

TRUSS PLATE MANUFACTURER IS NOT RESPONSIBLE FOR QUALITY CONTROL IN THE TRUSS MANUFACTURING PLANT.

**NAIL VALUES**

PLATE	GRIP(DRY)	SHEAR (PSI)	SECTION (PLI)
MT20	650	371	1747
	788	1987	1873

PLATE PLACEMENT TOL. = 0.250 inches

PLATE ROTATION TOL. = 5.0 Deg.

JSI GRIP= 0.86 (L) (INPUT = 0.90)  
JSI METAL= 0.42 (A) (INPUT = 1.00)

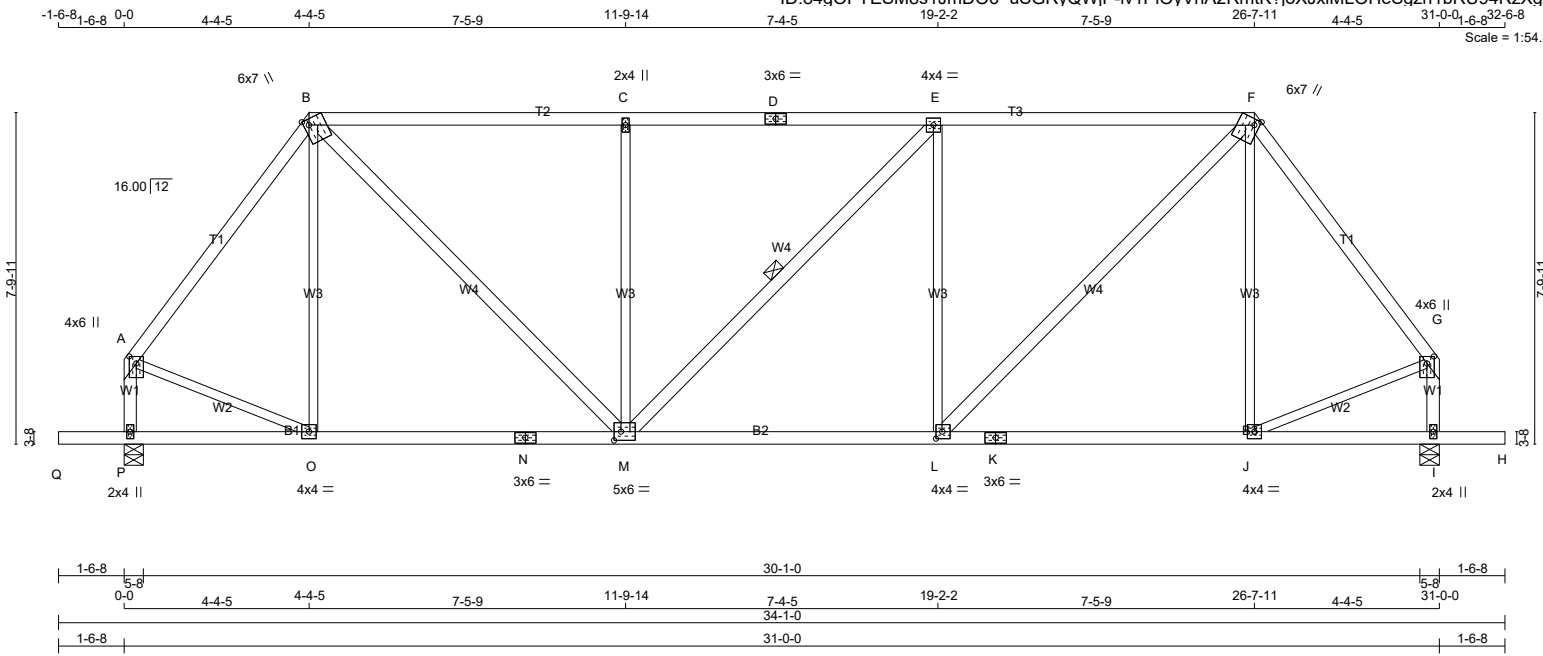

TOTAL WEIGHT = 2 X 151 = 302 lb

**LUMBER**

N. L. G. A. RULES	CHORDS	SIZE	LUMBER	DESCR.
A - B	2x4	DRY	No.2	SPF
B - D	2x4	DRY	No.2	SPF
D - F	2x4	DRY	No.2	SPF
F - G	2x4	DRY	No.2	SPF
P - A	2x4	DRY	No.2	SPF
I - G	2x4	DRY	No.2	SPF
Q - N	2x4	DRY	No.2	SPF
N - K	2x4	DRY	No.2	SPF
K - H	2x4	DRY	No.2	SPF
ALL WEBS EXCEPT	2x3	DRY	No.2	SPF
B - M	2x4	DRY	No.2	SPF
M - E	2x4	DRY	No.2	SPF
L - F	2x4	DRY	No.2	SPF

DRY: SEASONED LUMBER.

**PLATES (table is in inches)**

JT	TYPE	PLATES	W	LEN	Y	X
A	TMVW+p	MT20	4.0	6.0	2.00	2.00
B	TTWW+m	MT20	6.0	7.0	Edge	1.50
C	TMW+w	MT20	2.0	4.0		
D	TS-t	MT20	3.0	6.0		
E	TMWW-t	MT20	4.0	4.0		
F	TTWW+m	MT20	6.0	7.0	Edge	1.50
G	TMVW+p	MT20	4.0	6.0	2.00	2.00
I	BMV1+p	MT20	2.0	4.0		
J	BMWW-t	MT20	4.0	4.0		
K	BS-t	MT20	3.0	6.0		
L	BMWW-t	MT20	4.0	4.0	2.00	1.75
M	BMWW-t	MT20	5.0	6.0	2.50	2.00
N	BS-t	MT20	3.0	6.0		
O	BMWW-t	MT20	4.0	4.0		
P	BMV1+p	MT20	2.0	4.0		

Edge - INDICATES REFERENCE CORNER OF PLATE TOUCHES EDGE OF CHORD.

LATERAL BRACE(S) SHOWN SHALL BE 2X4 SPF#2



**DIMENSIONS, SUPPORTS AND LOADINGS SPECIFIED BY FABRICATOR TO BE VERIFIED BY BUILDING DESIGNER**

**BEARINGS**

JT	FACTORED GROSS REACTION		MAXIMUM FACTORED GROSS REACTION		INPUT BRG	REQRD BRG
	VERT	HORZ	DOWN	HORZ		
P	1644	0	1644	0	5-8	2-7
I	1644	0	1644	0	5-8	2-7

**UNFACTORED REACTIONS**

JT	1ST LCASE		MAX./MIN. COMPONENT REACTIONS				DEAD	SOIL
	COMBINED	SNOW	LIVE	PERM.LIVE	WIND	WIND		
P	1172	715/0	0/0	0/0	0/0	457/0	0/0	
I	1172	715/0	0/0	0/0	0/0	457/0	0/0	

BEARING MATERIAL TO BE SPF NO.2 OR BETTER AT JOINT(S) P, I

**BRACING**  
TOP CHORD TO BE SHEATHED OR MAX. PURLIN SPACING = 4.35 FT.  
MAX. UNBRACED BOTTOM CHORD LENGTH = 10.00 FT OR RIGID CEILING DIRECTLY APPLIED.

ALL PITCH BREAKS AND PERIMETER CORNER JOINTS MUST BE Laterally RESTRAINED.

1 LATERAL BRACE(S) AT 1/2 LENGTH OF E-M.

END VERTICAL(S) MUST BE SHEATHED OR HAVE BRACES AS INDICATED IN THE MAX. UNBRACED LENGTH COLUMN OF THE TABLE BELOW

**LOADING**

TOTAL LOAD CASES: (4)

MEMB.	C H O R D S				W E B S			
	MAX. FACTORED FORCE (LBS)	FACTORED VERT. LOAD (PLF)	LC1 MAX (CSI(LC))	UNBRAC LENGTH FROM TO	MAX. MEMB. UNBRAC LENGTH	MAX. FACTORED FORCE (LBS)	MAX. FACTORED CSI (LC)	
A-B	-1277/0	-78.0	-78.0	0.33 (1)	5.35	O-B	-151/28	0.17 (1)
B-C	-1521/0	-78.0	-78.0	0.74 (1)	4.36	B-M	0/1077	0.17 (1)
C-D	-1521/0	-78.0	-78.0	0.74 (1)	4.35	M-C	-624/0	0.71 (1)
D-E	-1521/0	-78.0	-78.0	0.74 (1)	4.35	M-E	-1/0	0.00 (1)
E-F	-1522/0	-78.0	-78.0	0.75 (1)	4.35	L-E	-624/0	0.71 (1)
F-G	-1277/0	-78.0	-78.0	0.33 (1)	5.35	L-F	0/1078	0.17 (1)
P-A	-1469/0	0.0	0.0	0.17 (1)	6.75	J-F	-152/28	0.17 (1)
I-G	-1469/0	0.0	0.0	0.17 (1)	6.75	A-O	0/810	0.18 (1)
J-G						J-G	0/810	0.18 (1)
Q-P	0/0	-96.5	-96.5	0.16 (1)	10.00			
P-O	0/0	-18.5	-18.5	0.16 (4)	10.00			
O-N	0/760	-18.5	-18.5	0.27 (4)	10.00			
N-M	0/760	-18.5	-18.5	0.27 (4)	10.00			
M-L	0/1522	-18.5	-18.5	0.36 (1)	10.00			
L-K	0/760	-18.5	-18.5	0.27 (4)	10.00			
K-J	0/760	-18.5	-18.5	0.27 (4)	10.00			
J-I	0/0	-18.5	-18.5	0.16 (4)	10.00			
I-H	0/0	-96.5	-96.5	0.16 (1)	10.00			

**DESIGN CRITERIA**

**SPECIFIED LOADS:**

TOP CH.	LL	DL	PSF
		21.0	PSF
		6.0	PSF
BOT CH.	LL	0.0	PSF
	DL	7.4	PSF
TOTAL LOAD		34.4	PSF

**SPACING = 24.0 IN./C/C**

LOADING IN FLAT SECTION BASED ON A SLOPE OF 2.00/12 MINIMUM

THIS TRUSS IS DESIGNED FOR RESIDENTIAL OR SMALL BUILDING REQUIREMENTS OF PART 9, NBC 2015

THIS DESIGN COMPLIES WITH:  
- PART 9 OF CBC 2018, ABC 2019  
- PART 9 OF OBC 2012 (2019 AMENDMENT)  
- CSA 086-14  
- TPIC 2014

(55% OF 23.0 P.S.F. G.S.L. PLUS 8.4 P.S.F. RAIN LOAD) EQUALS 21.0 P.S.F. SPECIFIED ROOF LIVE LOAD

ALLOWABLE DEFL.(LL)= L/360 (1.03")  
CALCULATED VERT. DEFL.(LL) = L/999 (0.06")  
ALLOWABLE DEFL.(TL)= L/360 (1.03")  
CALCULATED VERT. DEFL.(TL) = L/999 (0.13")

CANTILEVER DEFLECTION:  
ALLOWABLE DEFL.(LL)= L/120 (0.19")  
CALCULATED VERT. DEFL.(LL) = L/999 (0.01")  
ALLOWABLE DEFL.(TL)= L/120 (0.19")  
CALCULATED VERT. DEFL.(TL) = L/999 (0.01")

CSI: TC=0.75/1.00 (E-F:1), BC=0.36/1.00 (L-M:1), WB=0.71/1.00 (E-L:1), SSI=0.27/1.00 (E-F:1)

DOL LUMBER=1.00 NAIL=1.00 LS BEND=1.10 COMP=1.10 SHEAR=1.10 TENS=1.10

COMPANION LIVE LOAD FACTOR = 1.00

TRUSS PLATE MANUFACTURER IS NOT RESPONSIBLE FOR QUALITY CONTROL IN THE TRUSS MANUFACTURING PLANT.

**NAIL VALUES**

PLATE	GRIP(DRY)	SHEAR (PSI)	SECTION (PLI)
MT20	650	371	1747
	788	1987	1873

PLATE PLACEMENT TOL. = 0.250 inches

PLATE ROTATION TOL. = 5.0 Deg.

JSI GRIP= 0.90 (O) (INPUT = 0.90)  
JSI METAL= 0.44 (A) (INPUT = 1.00)

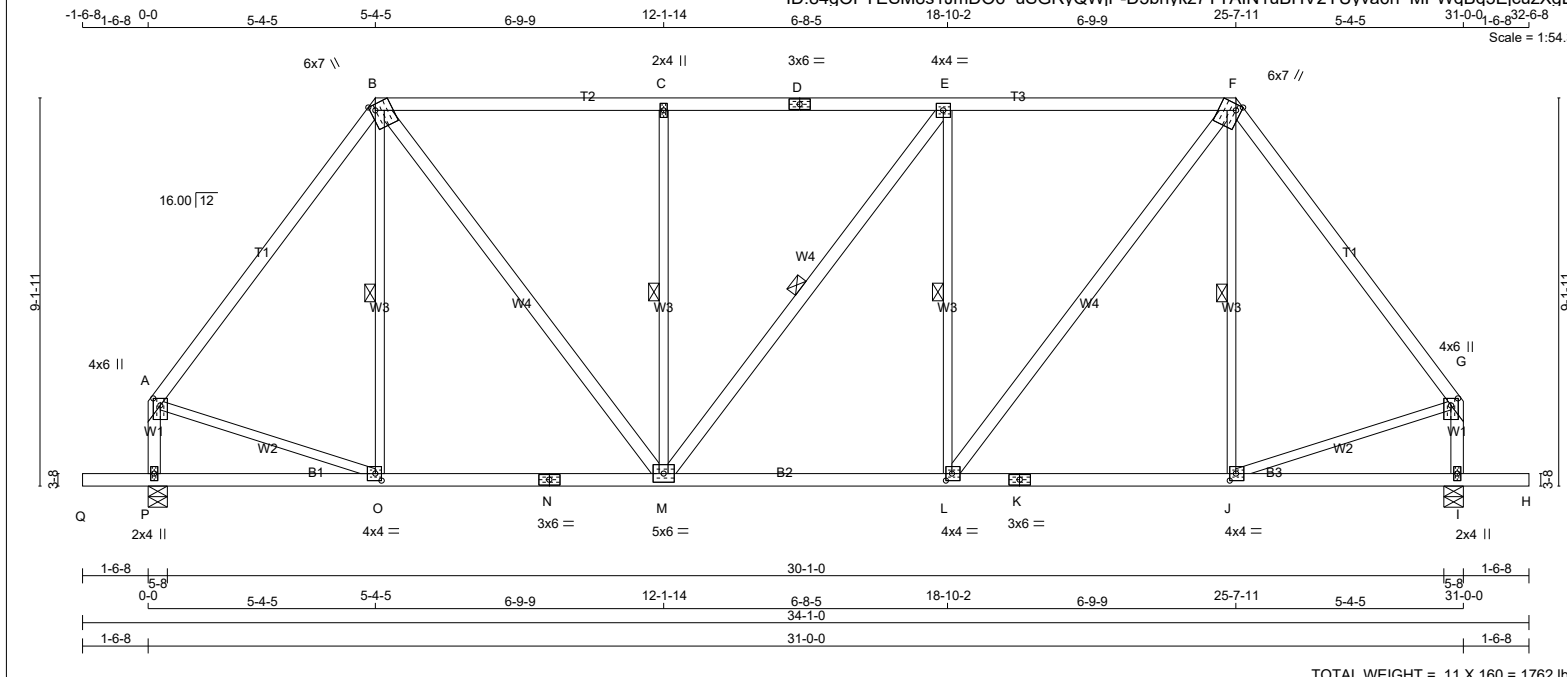

TOTAL WEIGHT = 11 X 160 = 1762 lb

**LUMBER**

N. L. G. A. RULES	CHORDS	SIZE	LUMBER	DESCR.
A - B	2x4	DRY	No.2	SPF
B - D	2x4	DRY	No.2	SPF
D - F	2x4	DRY	No.2	SPF
F - G	2x4	DRY	No.2	SPF
P - A	2x4	DRY	No.2	SPF
I - G	2x4	DRY	No.2	SPF
Q - N	2x4	DRY	No.2	SPF
N - K	2x4	DRY	No.2	SPF
K - H	2x4	DRY	No.2	SPF
ALL WEBS EXCEPT	2x3	DRY	No.2	SPF
B - M	2x4	DRY	No.2	SPF
M - E	2x4	DRY	No.2	SPF
L - F	2x4	DRY	No.2	SPF

DRY: SEASONED LUMBER.

**PLATES (table is in inches)**

JT	TYPE	PLATES	W	LEN	Y	X
A	TMVW+p	MT20	4.0	6.0	2.00	2.00
B	TTWW+m	MT20	6.0	7.0	Edge	1.50
C	TMW+w	MT20	2.0	4.0		
D	TS-t	MT20	3.0	6.0		
E	TMWW-t	MT20	4.0	4.0		
F	TTWW+m	MT20	6.0	7.0	Edge	1.50
G	TMVW+p	MT20	4.0	6.0	2.00	2.00
I	BMV1+p	MT20	2.0	4.0		
J, L, O						
K	BMWW-t	MT20	4.0	4.0	2.00	1.75
M	BS-t	MT20	3.0	6.0		
N	BMWW-t	MT20	5.0	6.0		
P	BS-t	MT20	3.0	6.0		
	BMV1+p	MT20	2.0	4.0		

Edge - INDICATES REFERENCE CORNER OF PLATE TOUCHES EDGE OF CHORD.

LATERAL BRACE(S) SHOWN SHALL BE 2X4 SPF#2



**DIMENSIONS, SUPPORTS AND LOADINGS SPECIFIED BY FABRICATOR TO BE VERIFIED BY BUILDING DESIGNER**

**BEARINGS**

JT	FACTORED GROSS REACTION		MAXIMUM FACTORED GROSS REACTION		INPUT BRG	REQRD IN-SX
	VERT	HORZ	DOWN	HORZ		
P	1720	0	1720	0	5-8	2-9
I	1720	0	1720	0	5-8	2-9

**UNFACTORED REACTIONS**

JT	COMBINED	MAX./MIN. COMPONENT REACTIONS				WIND	DEAD	SOIL
		1ST LCASE	SNOW	LIVE	PERM.LIVE			
P	1233	715 / 0	0 / 0	0 / 0	0 / 0	518 / 0	0 / 0	
I	1233	715 / 0	0 / 0	0 / 0	0 / 0	518 / 0	0 / 0	

BEARING MATERIAL TO BE SPF NO.2 OR BETTER AT JOINT(S) P, I

**BRACING**  
FOR SECTION B-F, MAX. PURLIN SPACING = 2.00 FT.  
FOR OTHER SECTIONS, TOP CHORD TO BE SHEATHED OR MAX. PURLIN SPACING = 5.22 FT.  
MAX. UNBRACED BOTTOM CHORD LENGTH = 10.00 FT OR RIGID CEILING DIRECTLY APPLIED.

ALL PITCH BREAKS AND PERIMETER CORNER JOINTS MUST BE LATERALLY RESTRAINED.

1 LATERAL BRACE(S) AT 1/2 LENGTH OF B-O, C-M, E-M, E-L, F-J.

END VERTICAL(S) MUST BE SHEATHED OR HAVE BRACES AS INDICATED IN THE MAX. UNBRACED LENGTH COLUMN OF THE TABLE BELOW

**LOADING**  
TOTAL LOAD CASES: (4)

MEMB.	CHORDS		FACTORED		MAX. UNBRAC LENGTH	WEBS	
	MAX. FORCE (LBS)	VERT. LOAD (PLF)	VERT. LOAD (PLF)	LC1 MAX (LC)		MEMB. FORCE (LBS)	MAX. FORCE (LBS)
FR-TO							
A-B	-1355 / 0	-78.0	-78.0	0.37 (1)	5.22	O-B	-112 / 36
B-C	-1383 / 0	-85.5	-85.5	0.49 (1)	2.00	B-M	0 / 941
C-D	-1383 / 0	-85.5	-85.5	0.45 (1)	2.00	M-C	-622 / 0
D-E	-1383 / 0	-85.5	-85.5	0.45 (1)	2.00	M-E	-2 / 0
E-F	-1384 / 0	-85.5	-85.5	0.49 (1)	2.00	L-E	-622 / 0
F-G	-1354 / 0	-78.0	-78.0	0.37 (1)	5.22	L-F	0 / 944
P-A	-1533 / 0	0.0	0.0	0.18 (1)	6.64	J-F	-113 / 36
I-G	-1533 / 0	0.0	0.0	0.18 (1)	6.64	A-O	0 / 844
						J-G	0 / 843
Q-P	0 / 0	-96.5	-96.5	0.16 (1)	10.00		
P-O	0 / 0	-18.5	-18.5	0.16 (4)	10.00		
O-N	0 / 808	-18.5	-18.5	0.25 (4)	10.00		
N-M	0 / 808	-18.5	-18.5	0.25 (4)	10.00		
M-L	0 / 1385	-18.5	-18.5	0.31 (1)	10.00		
L-K	0 / 808	-18.5	-18.5	0.25 (4)	10.00		
K-J	0 / 808	-18.5	-18.5	0.25 (4)	10.00		
J-I	0 / 0	-18.5	-18.5	0.16 (4)	10.00		
I-H	0 / 0	-96.5	-96.5	0.16 (1)	10.00		

**DESIGN CRITERIA**

**SPECIFIED LOADS:**  
TOP CH. LL = 21.0 PSF  
DL = 6.0 PSF  
BOT CH. LL = 0.0 PSF  
DL = 7.4 PSF  
TOTAL LOAD = 34.4 PSF

**SPACING = 24.0 IN./C**

LOADING IN FLAT SECTION BASED ON PIGGYBACK TRUSS WITH SLOPES OF 6.00/12 AND -6.00/12 AND RESPECTIVE WALL HEIGHTS OF 0-0 AND 0-0 AND AN ADDITIONAL DEAD LOAD OF 3.0 P.S.F.

THIS TRUSS IS DESIGNED FOR RESIDENTIAL OR SMALL BUILDING REQUIREMENTS OF PART 9, NBC 2015

THIS DESIGN COMPLIES WITH:  
- PART 9 OF CBC 2018, ABC 2019  
- PART 9 OF OBC 2012 (2019 AMENDMENT)  
- CSA 086-14  
- TPIC 2014

(55% OF 23.0 P.S.F. G.S.L. PLUS 8.4 P.S.F. RAIN LOAD) EQUALS 21.0 P.S.F. SPECIFIED ROOF LIVE LOAD

ALLOWABLE DEFL.(LL)= L/360 (1.03")  
CALCULATED VERT. DEFL.(LL)= L/999 (0.05")  
ALLOWABLE DEFL.(TL)= L/360 (1.03")  
CALCULATED VERT. DEFL.(TL)= L/999 (0.11")

CANTILEVER DEFLECTION:  
ALLOWABLE DEFL.(LL)= L/120 (0.19")  
CALCULATED VERT. DEFL.(LL)= L/999 (0.01")  
ALLOWABLE DEFL.(TL)= L/120 (0.19")  
CALCULATED VERT. DEFL.(TL)= L/999 (0.01")

CSI: TC=0.49/1.00 (E-F:1), BC=0.31/1.00 (L-M:1), WB=0.34/1.00 (E-L:1), SSI=0.27/1.00 (E-F:1)

DOL LUMBER=1.00 NAIL=1.00 LS BEND=1.10 COMP=1.10 SHEAR=1.10 TENS=1.10

COMPANION LIVE LOAD FACTOR = 1.00

TRUSS PLATE MANUFACTURER IS NOT RESPONSIBLE FOR QUALITY CONTROL IN THE TRUSS MANUFACTURING PLANT.

**NAIL VALUES**

PLATE	GRIP(DRY)	SHEAR (PSI)	SECTION (PLI)
MT20	650	371	1747 788 1987 1873

PLATE PLACEMENT TOL. = 0.250 inches

PLATE ROTATION TOL. = 5.0 Deg.

JSI GRIP= 0.85 (A) (INPUT = 0.90)  
JSI METAL= 0.47 (A) (INPUT = 1.00)

JOB NAME <b>318396</b>	TRUSS NAME <b>H11P</b>	QUANTITY	PLY <b>1</b>	JOB DESC. <b>TRUSS DESC. JT 45147</b>	DRWG NO. <b>E20035382</b>
---------------------------	---------------------------	----------	-----------------	--	------------------------------

Alpa Roof Truss, Maple Version 8.310 S Oct 29 2019 MiTek Industries, Inc. Tue Mar 24 17:21:13 2020 Page 1  
 ID:MF8iiriaTok7DlbpT4B71Xys4PG-D5bnykz7YTAIN1uBHV2YUyVU1h CPa9Bq5EjczXgEq

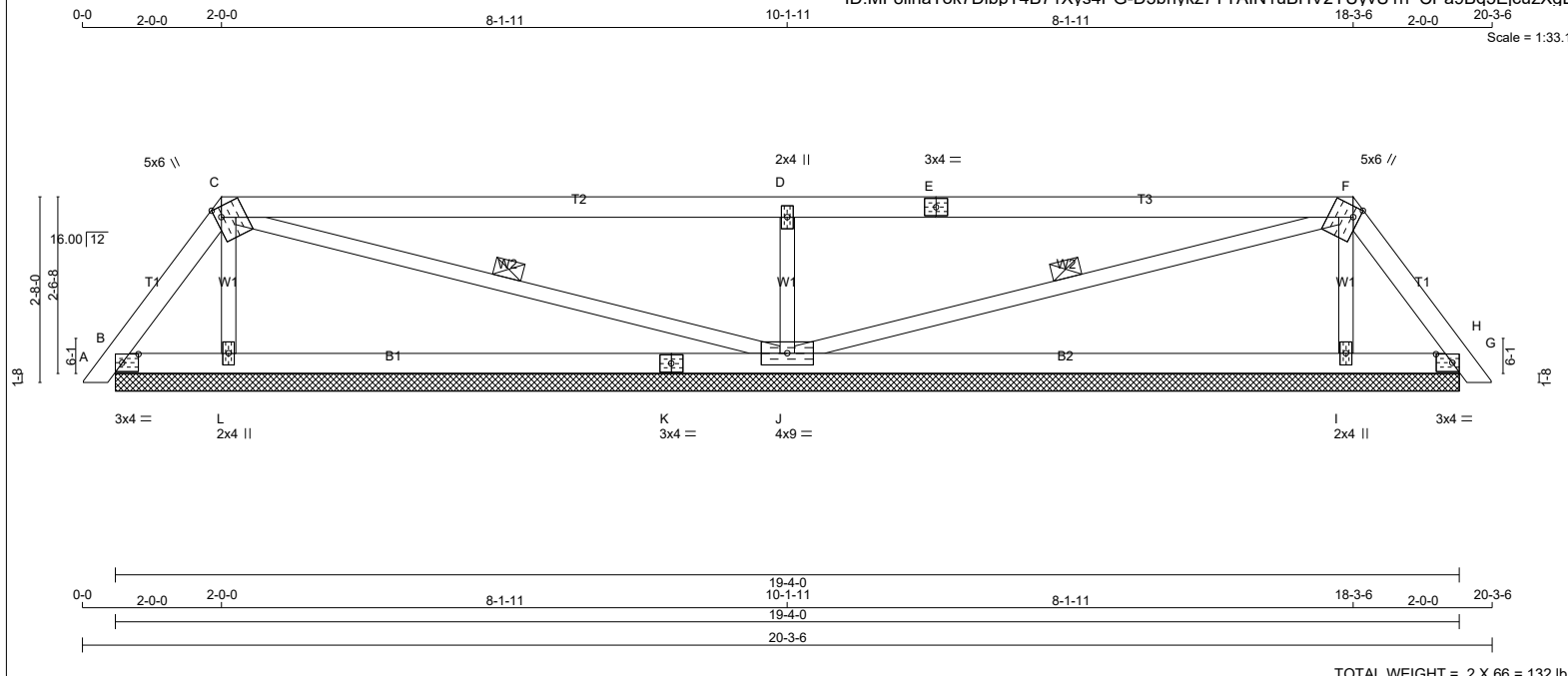

**LUMBER**

N. L. G. A. RULES

CHORDS	SIZE	LUMBER	DESCR.
A - C	2x4	DRY No.2	SPF
C - E	2x4	DRY No.2	SPF
E - F	2x4	DRY No.2	SPF
F - H	2x4	DRY No.2	SPF
B - K	2x4	DRY No.2	SPF
K - G	2x4	DRY No.2	SPF
ALL WEBS	2x3	DRY No.2	SPF

DRY: SEASONED LUMBER.

**PLATES (table is in inches)**

JT TYPE	PLATES	W	LEN	Y	X	
B	TMB1-l	MT20	3.0	4.0	1.50	2.75
C	TTWW+m	MT20	5.0	6.0	1.75	1.00
D	TMW+w	MT20	2.0	4.0		
E	TS-t	MT20	3.0	4.0		
F	TTWW+m	MT20	5.0	6.0	1.75	1.00
G	TMB1-l	MT20	3.0	4.0	1.50	2.75
I	BMW1+w	MT20	2.0	4.0		
J	BMW1+w	MT20	4.0	9.0		
K	BS-t	MT20	3.0	4.0		
L	BMW1+w	MT20	2.0	4.0		

LATERAL BRACE(S) SHOWN SHALL BE  
2X4 SPF#2

**DIMENSIONS, SUPPORTS AND LOADINGS SPECIFIED BY FABRICATOR TO BE VERIFIED BY BUILDING DESIGNER**

**BEARINGS**

JT	FACTORED GROSS REACTION		MAXIMUM FACTORED GROSS REACTION		INPUT BRG	REQRD BRG
	VERT	HORZ	DOWN	HORZ		
B	143	0	143	0	19-4-0 (11-4-0)5-9	
L	342	0	342	0	19-4-0 (11-4-0)5-9	
J	950	0	950	0	19-4-0 (11-4-0)5-9	
I	342	0	342	0	19-4-0 (11-4-0)5-9	
G	143	0	143	0	19-4-0 (11-4-0)5-9	

VALUE IN PARENTHESIS INDICATES EFFECTIVE BEARING LENGTH

**UNFACTORED REACTIONS**

JT	1ST LCASE		MAX./MIN. COMPONENT REACTIONS				
	COMBINED	SNOW	LIVE	PERM.LIVE	WIND	DEAD	SOIL
B	95	95/0	0/0	0/0	0/0	0/0	0/0
L	251	112/0	0/0	0/0	0/0	140/0	0/0
J	675	428/0	0/0	0/0	0/0	247/0	0/0
I	251	112/0	0/0	0/0	0/0	140/0	0/0
G	95	95/0	0/0	0/0	0/0	0/0	0/0

BEARING MATERIAL TO BE SPF NO.2 OR BETTER AT JOINT(S) B, L, J, I, G

**BRACING**  
TOP CHORD TO BE SHEATHED OR MAX. PURLIN SPACING = 6.25 FT.  
MAX. UNBRACED BOTTOM CHORD LENGTH = 10.00 FT OR RIGID CEILING DIRECTLY APPLIED.

ALL PITCH BREAKS AND PERIMETER CORNER JOINTS MUST BE LATERALLY RESTRAINED.  
1 LATERAL BRACE(S) AT 1/2 LENGTH OF C-J, F-J.

**LOADING**  
TOTAL LOAD CASES: (4)

MEMB.	FR-TO	CHORDS			WEBS			
		MAX. FACTORED FORCE (LBS)	FACTORED VERT. LOAD (PLF)	FACTORED LC1 MAX CSI (LC)	MAX. UNBRACED LENGTH	MEMB. FR-TO	MAX. FACTORED FORCE (LBS)	MAX. FACTORED CSI (LC)
A-B	0/10	-78.0	-78.0	0.01 (1)	10.00	L-C	-208/0	0.03 (1)
B-C	-109/0	-78.0	-78.0	0.03 (1)	6.25	C-J	-3/0	0.00 (1)
C-D	-49/0	-78.0	-78.0	0.88 (1)	6.25	J-D	-793/0	0.13 (1)
D-E	-50/0	-78.0	-78.0	0.88 (1)	6.25	J-F	-3/0	0.00 (1)
E-F	-50/0	-78.0	-78.0	0.88 (1)	6.25	I-F	-208/0	0.03 (1)
F-G	-109/0	-78.0	-78.0	0.03 (1)	6.25			
G-H	0/10	-78.0	-78.0	0.01 (1)	10.00			
B-L	0/62	-18.5	-18.5	0.19 (4)	10.00			
L-K	0/52	-18.5	-18.5	0.26 (4)	10.00			
K-J	0/52	-18.5	-18.5	0.26 (4)	10.00			
J-I	0/52	-18.5	-18.5	0.26 (4)	10.00			
I-G	0/62	-18.5	-18.5	0.19 (4)	10.00			

**DESIGN CRITERIA**

**SPECIFIED LOADS:**  
TOP CH. LL = 21.0 PSF  
DL = 6.0 PSF  
BOT CH. LL = 0.0 PSF  
DL = 7.4 PSF  
TOTAL LOAD = 34.4 PSF

**SPACING = 24.0 IN./C**

LOADING IN FLAT SECTION BASED ON A SLOPE OF 2.00/12 MINIMUM

THIS TRUSS IS DESIGNED FOR RESIDENTIAL OR SMALL BUILDING REQUIREMENTS OF PART 9, NBC 2015

THIS DESIGN COMPLIES WITH:  
- PART 9 OF CBC 2018, ABC 2019  
- PART 9 OF OBC 2012 (2019 AMENDMENT)  
- CSA 086-14  
- TPIC 2014

(55% OF 23.0 P.S.F. G.S.L. PLUS 8.4 P.S.F. RAIN LOAD) EQUALS 21.0 P.S.F. SPECIFIED ROOF LIVE LOAD

CSI: TC=0.88/1.00 (D-F:1), BC=0.26/1.00 (J-L:4), WB=0.13/1.00 (D-J:1), SSI=0.31/1.00 (C-D:1)

DOL LUMBER=1.00 NAIL=1.00 LS BEND=1.10 COMP=1.10 SHEAR=1.10 TENS= 1.10

COMPANION LIVE LOAD FACTOR = 1.00

TRUSS PLATE MANUFACTURER IS NOT RESPONSIBLE FOR QUALITY CONTROL IN THE TRUSS MANUFACTURING PLANT.

**NAIL VALUES**

PLATE	GRIP(DRY) (PSI)	SHEAR (PLI)	SECTION (PLI)
MT20	650	371	1747 788 1987 1873

PLATE PLACEMENT TOL. = 0.250 inches

PLATE ROTATION TOL. = 5.0 Deg.

JSI GRIP= 0.62 (C) (INPUT = 0.90)  
JSI METAL= 0.18 (E) (INPUT = 1.00)



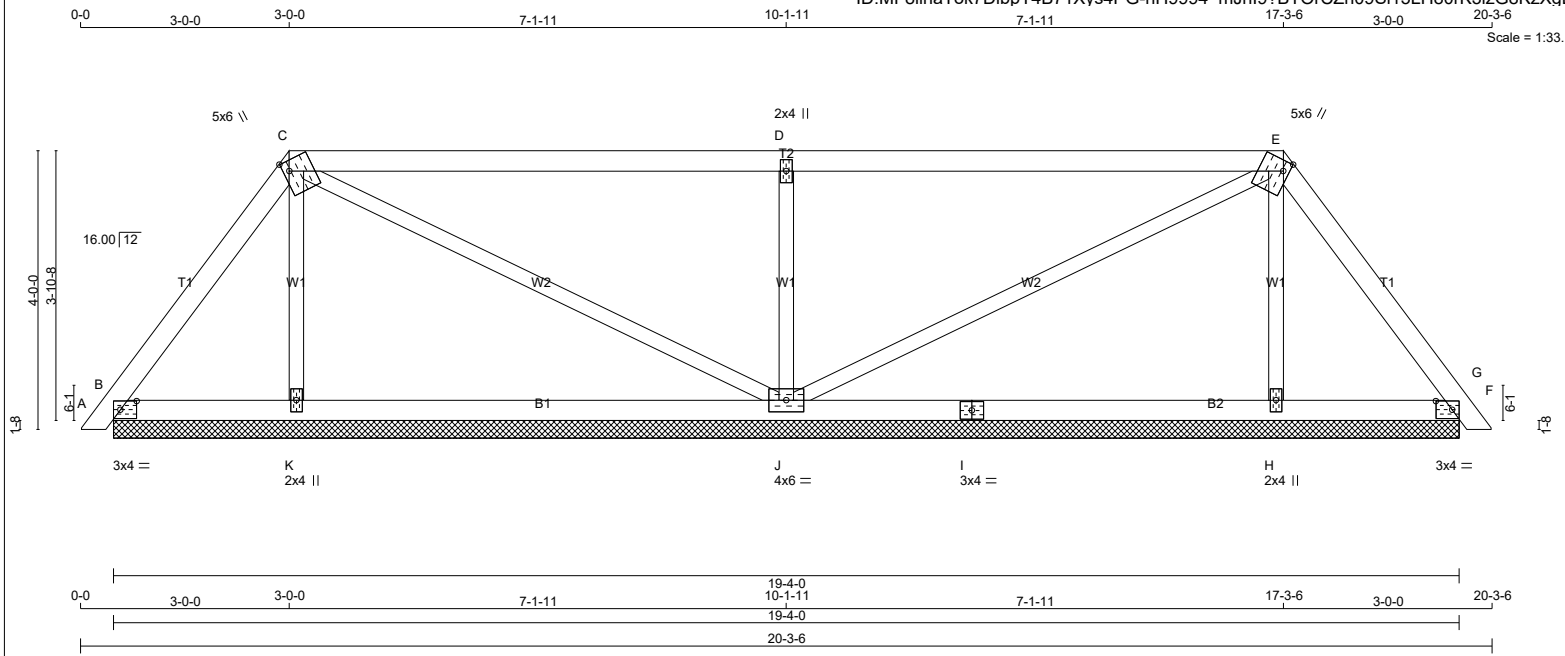

TOTAL WEIGHT = 2 X 70 = 140 lb

**LUMBER**

N. L. G. A. RULES

CHORDS	SIZE	LUMBER	DESCR.
A - C	2x4	DRY No.2	SPF
C - E	2x4	DRY No.2	SPF
E - G	2x4	DRY No.2	SPF
B - I	2x4	DRY No.2	SPF
I - F	2x4	DRY No.2	SPF
ALL WEBS	2x3	DRY No.2	SPF

DRY: SEASONED LUMBER.

**PLATES (table is in inches)**

JT	TYPE	PLATES	W	LEN	Y	X
B	TMB1-l	MT20	3.0	4.0	1.50	2.75
C	TTWW+m	MT20	5.0	6.0	1.75	1.00
D	TMW+w	MT20	2.0	4.0		
E	TTWW+m	MT20	5.0	6.0	1.75	1.00
F	TMB1-l	MT20	3.0	4.0	1.50	2.75
H	BMW1+w	MT20	2.0	4.0		
I	BS-l	MT20	3.0	4.0		
J	BMW1+w	MT20	4.0	6.0		
K	BMW1+w	MT20	2.0	4.0		

**DIMENSIONS, SUPPORTS AND LOADINGS SPECIFIED BY FABRICATOR TO BE VERIFIED BY BUILDING DESIGNER**

**BEARINGS**

JT	FACTORED GROSS REACTION		MAXIMUM FACTORED GROSS REACTION		INPUT BRG	REQRD BRG
	VERT	HORZ	DOWN	HORZ		
F	213	0	213	0	19-4-0 (7-0-0) 1-5-4	
K	310	0	310	0	19-4-0 (7-0-0) 1-5-4	
J	875	0	875	0	19-4-0 (7-0-0) 1-5-4	
H	310	0	310	0	19-4-0 (7-0-0) 1-5-4	
B	213	0	213	0	19-4-0 (7-0-0) 1-5-4	

**DESIGN CRITERIA**

**SPECIFIED LOADS:**  
 TOP CH. LL = 21.0 PSF  
 DL = 6.0 PSF  
 BOT CH. LL = 0.0 PSF  
 DL = 7.4 PSF  
 TOTAL LOAD = 34.4 PSF

**SPACING = 24.0 IN./C/C**

LOADING IN FLAT SECTION BASED ON A SLOPE OF 2.00/12 MINIMUM

THIS TRUSS IS DESIGNED FOR RESIDENTIAL OR SMALL BUILDING REQUIREMENTS OF PART 9, NBC 2015

THIS DESIGN COMPLIES WITH:  
 - PART 9 OF CBC 2018, ABC 2019  
 - PART 9 OF OBC 2012 (2019 AMENDMENT)  
 - CSA 086-14  
 - TPIC 2014

(55% OF 23.0 P.S.F. G.S.L. PLUS 8.4 P.S.F. RAIN LOAD) EQUALS 21.0 P.S.F. SPECIFIED ROOF LIVE LOAD

CSI: TC=0.68/1.00 (C-D:1), BC=0.21/1.00 (H-J:4), WB=0.16/1.00 (D-J:1), SSI=0.27/1.00 (D-E:1)

DOL LUMBER=1.00 NAIL=1.00 LS BEND=1.10 COMP=1.10 SHEAR=1.10 TENS= 1.10

COMPANION LIVE LOAD FACTOR = 1.00

TRUSS PLATE MANUFACTURER IS NOT RESPONSIBLE FOR QUALITY CONTROL IN THE TRUSS MANUFACTURING PLANT.

**NAIL VALUES**  
 PLATE GRIP(DRY) SHEAR SECTION (PSI) (PLI) (PLI)  
 MAX MIN MAX MIN MAX MIN  
 MT20 650 371 1747 788 1987 1873

PLATE PLACEMENT TOL. = 0.250 inches

PLATE ROTATION TOL. = 5.0 Deg.

JSI GRIP= 0.73 (J) (INPUT = 0.90)  
 JSI METAL= 0.16 (I) (INPUT = 1.00)

VALUE IN PARENTHESIS INDICATES EFFECTIVE BEARING LENGTH

**UNFACTORED REACTIONS**

JT	1ST LCASE	MAX./MIN. COMPONENT REACTIONS					
		COMBINED	SNOW	LIVE	PERM.LIVE	WIND	DEAD
F	148	113 / 0	0 / 0	0 / 0	0 / 0	35 / 0	0 / 0
K	226	109 / 0	0 / 0	0 / 0	0 / 0	116 / 0	0 / 0
J	620	396 / 0	0 / 0	0 / 0	0 / 0	224 / 0	0 / 0
H	226	109 / 0	0 / 0	0 / 0	0 / 0	116 / 0	0 / 0
B	148	113 / 0	0 / 0	0 / 0	0 / 0	35 / 0	0 / 0

BEARING MATERIAL TO BE SPF NO.2 OR BETTER AT JOINT(S) F, K, J, H, B

**BRACING**

TOP CHORD TO BE SHEATHED OR MAX. PURLIN SPACING = 6.25 FT.  
 MAX. UNBRACED BOTTOM CHORD LENGTH = 10.00 FT OR RIGID CEILING DIRECTLY APPLIED.

ALL PITCH BREAKS AND PERIMETER CORNER JOINTS MUST BE Laterally RESTRAINED.

**LOADING**

TOTAL LOAD CASES: (4)

MEMB.	CHORDS MAX. FACTORED FORCE (LBS)	VERT. (PLF)	LOAD LC1	MAX CSI (LC)	MEMB. UNBRAC LENGTH	WEBS MAX. FACTORED FORCE (LBS)	MAX CSI (LC)
A-B	0 / 10	-78.0	-78.0	0.01 (1)	10.00	K-C	-203 / 0
B-C	-104 / 0	-78.0	-78.0	0.09 (1)	6.25	C-J	-46 / 0
C-D	-13 / 0	-78.0	-78.0	0.68 (1)	6.25	J-D	-695 / 0
D-E	-13 / 0	-78.0	-78.0	0.68 (1)	6.25	J-E	-46 / 0
E-F	-104 / 0	-78.0	-78.0	0.09 (1)	6.25	H-E	-203 / 0
F-G	0 / 10	-78.0	-78.0	0.01 (1)	10.00		
B-K	0 / 60	-18.5	-18.5	0.14 (4)	10.00		
K-J	0 / 54	-18.5	-18.5	0.21 (4)	10.00		
J-I	0 / 54	-18.5	-18.5	0.21 (4)	10.00		
I-H	0 / 54	-18.5	-18.5	0.21 (4)	10.00		
H-F	0 / 60	-18.5	-18.5	0.14 (4)	10.00		

LATERAL BRACE(S) SHOWN SHALL BE 2X4 SPF#2





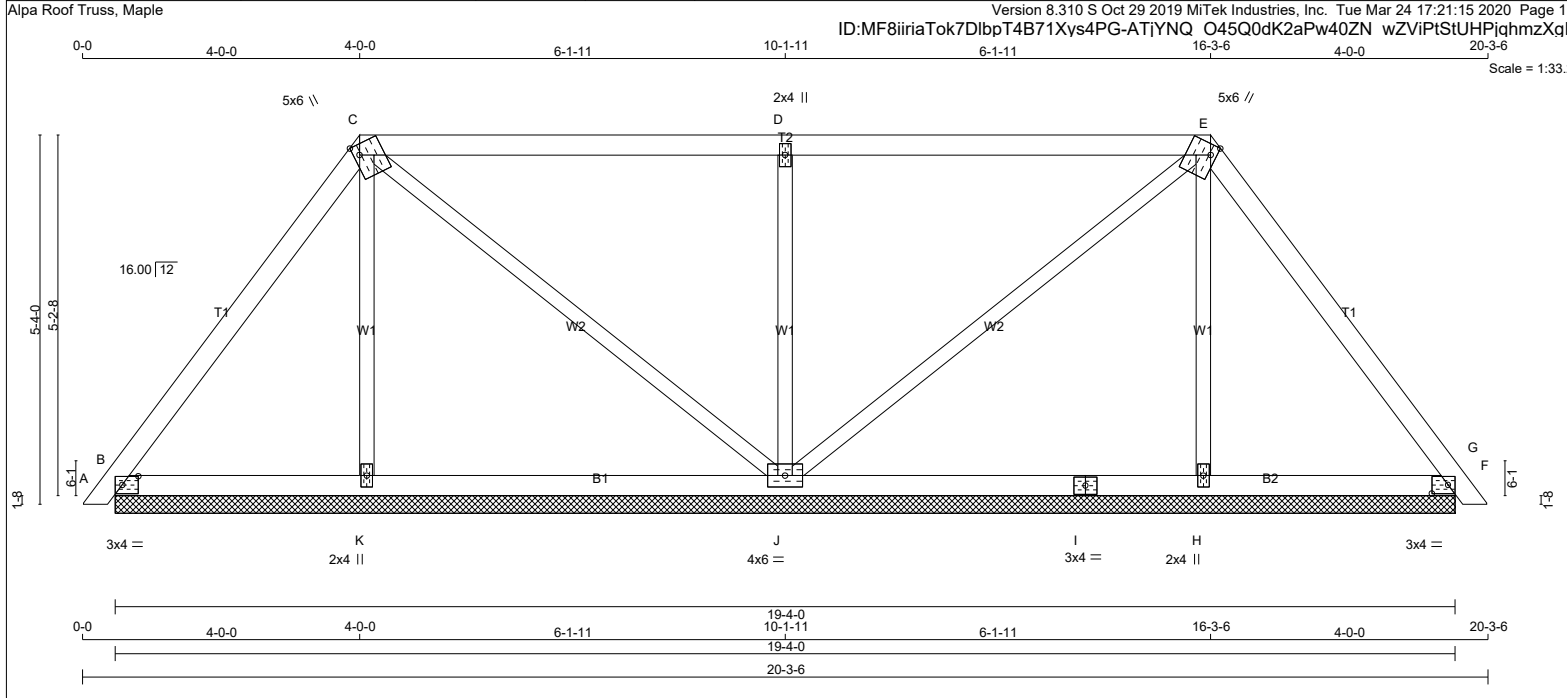

TOTAL WEIGHT = 3 X 75 = 224 lb

**LUMBER**

N. L. G. A. RULES

CHORDS	SIZE	LUMBER	DESCR.
A - C	2x4	DRY No.2	SPF
C - E	2x4	DRY No.2	SPF
E - G	2x4	DRY No.2	SPF
B - I	2x4	DRY No.2	SPF
I - F	2x4	DRY No.2	SPF
ALL WEBS	2x3	DRY No.2	SPF

DRY: SEASONED LUMBER.

**PLATES (table is in inches)**

JT	TYPE	PLATES	W	LEN	Y	X
B	TMB1-l	MT20	3.0	4.0	1.50	2.75
C	TTWW+m	MT20	5.0	6.0	1.75	1.00
D	TMW+w	MT20	2.0	4.0		
E	TTWW+m	MT20	5.0	6.0	1.75	1.00
F	TMB1-l	MT20	3.0	4.0	1.50	2.75
H	BMW1+w	MT20	2.0	4.0		
I	BS-l	MT20	3.0	4.0		
J	BMW1+w	MT20	4.0	6.0		
K	BMW1+w	MT20	2.0	4.0		

LATERAL BRACE(S) SHOWN SHALL BE 2X4 SPF#2



**DIMENSIONS, SUPPORTS AND LOADINGS SPECIFIED BY FABRICATOR TO BE VERIFIED BY BUILDING DESIGNER**

**BEARINGS**

JT	FACTORED GROSS REACTION		MAXIMUM FACTORED GROSS REACTION		INPUT BRG	REQRD BRG
	VERT	HORZ	DOWN	HORZ		
B	275	0	275	0	19-4-0 (5-4-0) 1-7-8	
K	283	0	283	0	19-4-0 (5-4-0) 1-7-8	
J	803	0	803	0	19-4-0 (5-4-0) 1-7-8	
H	283	0	283	0	19-4-0 (5-4-0) 1-7-8	
F	275	0	275	0	19-4-0 (5-4-0) 1-7-8	

VALUE IN PARENTHESIS INDICATES EFFECTIVE BEARING LENGTH

**UNFACTORED REACTIONS**

JT	1ST LCASE	MAX./MIN. COMPONENT REACTIONS				WIND	DEAD	SOIL
		SNOW	LIVE	PERM.LIVE				
B	193	137 / 0	0 / 0	0 / 0	0 / 0	56 / 0	0 / 0	
K	207	99 / 0	0 / 0	0 / 0	0 / 0	107 / 0	0 / 0	
J	569	369 / 0	0 / 0	0 / 0	0 / 0	199 / 0	0 / 0	
H	207	99 / 0	0 / 0	0 / 0	0 / 0	107 / 0	0 / 0	
F	193	137 / 0	0 / 0	0 / 0	0 / 0	56 / 0	0 / 0	

BEARING MATERIAL TO BE SPF NO.2 OR BETTER AT JOINT(S) B, K, J, H, F

**BRACING**  
TOP CHORD TO BE SHEATHED OR MAX. PURLIN SPACING = 6.25 FT.  
MAX. UNBRACED BOTTOM CHORD LENGTH = 10.00 FT OR RIGID CEILING DIRECTLY APPLIED.

ALL PITCH BREAKS AND PERIMETER CORNER JOINTS MUST BE Laterally RESTRAINED.

**LOADING**  
TOTAL LOAD CASES: (4)

MEMB.	CHORDS			MAX. UNBRACED LENGTH	MEMB.	WEBS		
	MAX. FACTORED FORCE (LBS)	FACTORED VERT. LOAD (PLF)	FACTORED LC1 MAX. CSI (LC)			MAX. FACTORED FORCE (LBS)	MAX. FACTORED CSI (LC)	
FR-TO		FROM TO			FR-TO			
A-B	0 / 10	-78.0 -78.0	0.01 (1)	10.00	K-C	-184 / 0	0.07 (1)	
B-C	-110 / 0	-78.0 -78.0	0.17 (1)	6.25	C-J	-71 / 0	0.09 (1)	
C-D	-4 / 0	-78.0 -78.0	0.50 (1)	10.00	J-D	-598 / 0	0.24 (1)	
D-E	-4 / 0	-78.0 -78.0	0.50 (1)	10.00	J-E	-71 / 0	0.09 (1)	
E-F	-110 / 0	-78.0 -78.0	0.17 (1)	6.25	H-E	-184 / 0	0.07 (1)	
F-G	0 / 10	-78.0 -78.0	0.01 (1)	10.00				
B-K	0 / 64	-18.5 -18.5	0.11 (4)	10.00				
K-J	0 / 60	-18.5 -18.5	0.15 (4)	10.00				
J-I	0 / 60	-18.5 -18.5	0.15 (4)	10.00				
I-H	0 / 60	-18.5 -18.5	0.15 (4)	10.00				
H-F	0 / 64	-18.5 -18.5	0.11 (4)	10.00				

**DESIGN CRITERIA**

**SPECIFIED LOADS:**  
TOP CH. LL = 21.0 PSF  
DL = 6.0 PSF  
BOT CH. LL = 0.0 PSF  
DL = 7.4 PSF  
TOTAL LOAD = 34.4 PSF

**SPACING = 24.0 IN./C**

LOADING IN FLAT SECTION BASED ON A SLOPE OF 2.00/12 MINIMUM

THIS TRUSS IS DESIGNED FOR RESIDENTIAL OR SMALL BUILDING REQUIREMENTS OF PART 9, NBC 2015

THIS DESIGN COMPLIES WITH:  
- PART 9 OF CBC 2018, ABC 2019  
- PART 9 OF OBC 2012 (2019 AMENDMENT)  
- CSA 086-14  
- TPIC 2014

(55% OF 23.0 P.S.F. G.S.L. PLUS 8.4 P.S.F. RAIN LOAD) EQUALS 21.0 P.S.F. SPECIFIED ROOF LIVE LOAD

CSI: TC=0.50/1.00 (C-D:1), BC=0.15/1.00 (J-K:4), WB=0.24/1.00 (D-J:1), SSI=0.23/1.00 (C-D:1)

DOL LUMBER=1.00 NAIL=1.00 LS BEND=1.10 COMP=1.10 SHEAR=1.10 TENS= 1.10

COMPANION LIVE LOAD FACTOR = 1.00

TRUSS PLATE MANUFACTURER IS NOT RESPONSIBLE FOR QUALITY CONTROL IN THE TRUSS MANUFACTURING PLANT.

**NAIL VALUES**  
PLATE GRIP(DRY) SHEAR SECTION (PSI) (PLI) (PLI)  
MAX MIN MAX MIN MAX MIN  
MT20 650 371 1747 788 1987 1873

PLATE PLACEMENT TOL. = 0.250 inches

PLATE ROTATION TOL. = 5.0 Deg.

JSI GRIP= 0.62 (C) (INPUT = 0.90)  
JSI METAL= 0.13 (F) (INPUT = 1.00)

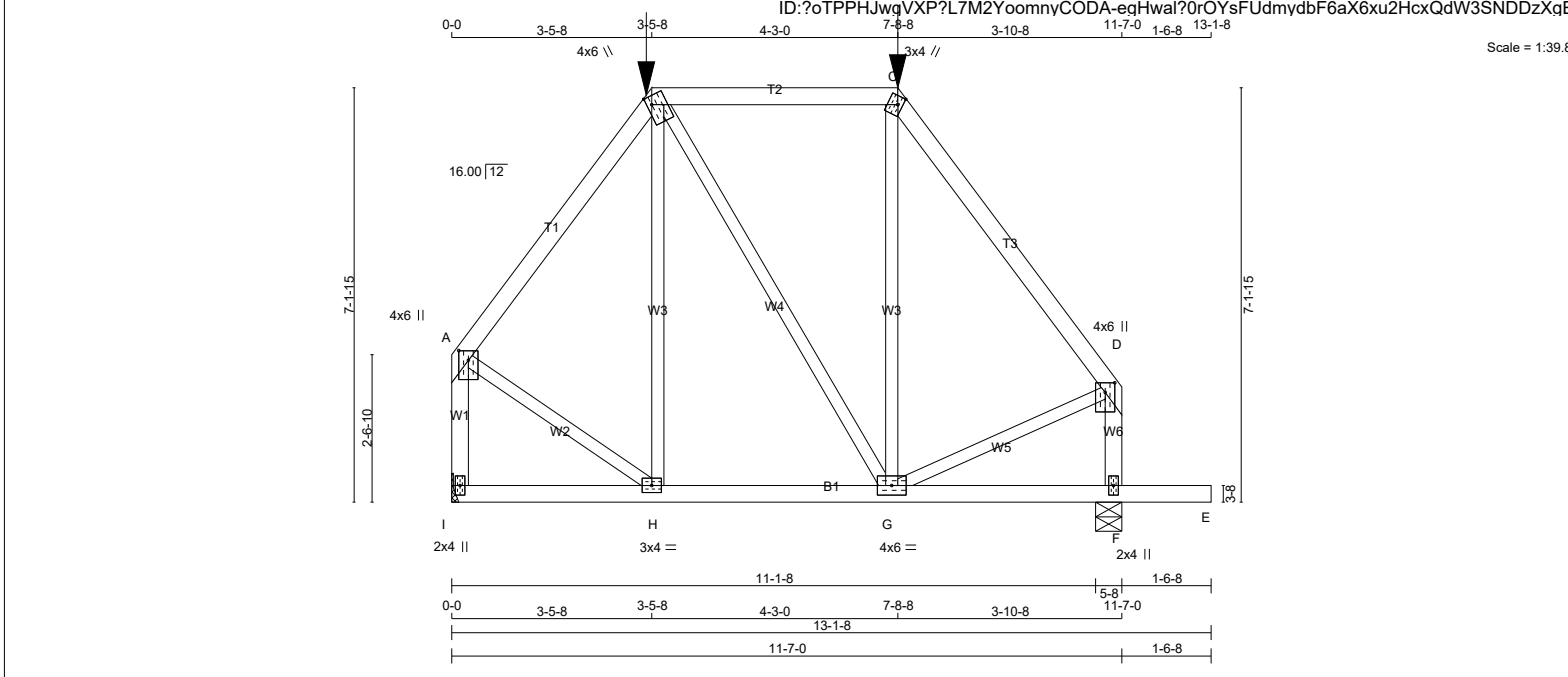

TOTAL WEIGHT = 62 lb [M]

**LUMBER**

N. L. G. A. RULES

CHORDS	SIZE	LUMBER	DESCR.
A - B	2x4 DRY	No.2	SPF
B - C	2x4 DRY	No.2	SPF
C - D	2x4 DRY	No.2	SPF
I - A	2x4 DRY	No.2	SPF
F - D	2x4 DRY	No.2	SPF
I - E	2x4 DRY	No.2	SPF
ALL WEBS EXCEPT	2x3 DRY	No.2	SPF

DRY: SEASONED LUMBER.

**PLATES (table is in inches)**

JT TYPE	PLATES	W	LEN	Y	X
A	TMVW+p MT20	4.0	6.0	2.00	2.00
B	TTWW+m MT20	4.0	6.0	1.75	1.00
C	TTW+m MT20	3.0	4.0	1.75	1.00
D	TMVW+p MT20	4.0	6.0	2.00	2.00
F	BMV1+p MT20	2.0	4.0		
G	BMWWW-t MT20	4.0	6.0		
H	BMWW-t MT20	3.0	4.0		
I	BMV1+p MT20	2.0	4.0		

LATERAL BRACE(S) SHOWN SHALL BE 2X4 SPF#2



**DIMENSIONS, SUPPORTS AND LOADINGS SPECIFIED BY FABRICATOR TO BE VERIFIED BY BUILDING DESIGNER**

**BEARINGS**

JT	FACTORED GROSS REACTION		MAXIMUM FACTORED GROSS REACTION		INPUT BRG	REQRD BRG
	VERT	HORZ	DOWN	HORZ		
I	804	0	804	0	MECHANICAL	
F	944	0	944	0	5-8	1-8

A SUITABLE HANGER/MECHANICAL CONNECTION IS REQUIRED AT JOINT I. MINIMUM BEARING LENGTH AT JOINT I = 1-8.

**UNFACTORED REACTIONS**

JT	COMBINED	MAX./MIN. COMPONENT REACTIONS					
		1ST LCASE	SNOW	LIVE	PERM.LIVE	WIND	DEAD
I	574	348 / 0	0 / 0	0 / 0	0 / 0	225 / 0	0 / 0
F	674	408 / 0	0 / 0	0 / 0	0 / 0	265 / 0	0 / 0

BEARING MATERIAL TO BE SPF NO.2 OR BETTER AT JOINT(S) F

**BRACING**  
TOP CHORD TO BE SHEATHED OR MAX. PURLIN SPACING = 6.25 FT.  
MAX. UNBRACED BOTTOM CHORD LENGTH = 10.00 FT OR RIGID CEILING DIRECTLY APPLIED.

ALL PITCH BREAKS AND PERIMETER CORNER JOINTS MUST BE Laterally RESTRAINED.

**LOADING**

TOTAL LOAD CASES: (4)

MEMB.	CHORDS				WEBS			
	MAX. FACTORED FORCE (LBS)	FACTORED VERT. LOAD (PLF)	LC1 MAX CSI (LC)	MAX. UNBRAC LENGTH	MEMB.	MAX. FACTORED FORCE (LBS)	MAX. FACTORED CSI (LC)	
FR-TO					FR-TO			
A-B	-542 / 0	-78.0	-78.0	0.19 (1)	6.25	H-B	-84 / 49	0.08 (1)
B-C	-342 / 0	-114.5	-114.5	0.39 (1)	6.25	B-G	0 / 40	0.01 (1)
C-D	-575 / 0	-78.0	-78.0	0.24 (1)	6.25	G-C	-52 / 68	0.05 (1)
I-A	-766 / 0	0.0	0.0	0.11 (1)	7.81	A-H	0 / 378	0.09 (1)
F-D	-751 / 0	0.0	0.0	0.09 (1)	7.81	G-D	0 / 370	0.09 (1)
I-H	0 / 0	-27.2	-27.2	0.09 (4)	10.00			
H-G	0 / 322	-27.2	-27.2	0.15 (4)	10.00			
G-F	0 / 0	-27.2	-27.2	0.11 (4)	10.00			
F-E	0 / 0	-96.5	-96.5	0.17 (1)	10.00			

FACTORED CONCENTRATED LOADS (LBS)

JT	LOC.	LC1	MAX-	MAX+	FACE	DIR.	TYPE	HEEL	CONN.
B	3-5-8	-107	-107	---	FRONT	VERT	TOTAL	---	C1
C	7-8-8	-120	-120	---	FRONT	VERT	TOTAL	---	C1

**CONNECTION REQUIREMENTS**

- C1:** A SUITABLE HANGER/MECHANICAL CONNECTION IS REQUIRED.

**DESIGN CRITERIA**

SPECIFIED LOADS:

TOP CH.	LL	DL	PSF
	21.0	6.0	PSF
BOT CH.	LL	DL	PSF
	0.0	7.4	PSF
<b>TOTAL LOAD</b>	<b>= 34.4</b>		<b>PSF</b>

**SPACING = 24.0 IN./C/C**

LOADING IN FLAT SECTION BASED ON A SLOPE OF 2.00/12 MINIMUM

GIRDER TYPE: CPrimeHip  
LEFT SETBACK = 3-5-8  
RIGHT SETBACK = 3-10-8  
END SETBACK = 3-10-8  
END WALL WIDTH = 0-0  
CORNER FRAMING TYPE: CONVENTIONAL  
END JACK TYPE: CONVENTIONAL  
APPLIED TO FRONT SIDE  
- ADDTL LOADS BASED ON 55 % OF GSL.

THIS TRUSS IS DESIGNED FOR RESIDENTIAL OR SMALL BUILDING REQUIREMENTS OF PART 9, NBCC 2015

THIS DESIGN COMPLIES WITH:  
- PART 9 OF BCBC 2018, ABC 2019  
- PART 9 OF OBC 2012 (2019 AMENDMENT)  
- CSA 086-14  
- TPIC 2014

(55 % OF 23.0 P.S.F. G.S.L. PLUS 8.4 P.S.F. RAIN LOAD) EQUALS 21.0 P.S.F. SPECIFIED ROOF LIVE LOAD

ALLOWABLE DEFL.(LL)= L/360 (0.39")  
CALCULATED VERT. DEFL.(LL) = L/ 999 (0.00")  
ALLOWABLE DEFL.(TL)= L/360 (0.39")  
CALCULATED VERT. DEFL.(TL) = L/ 999 (0.01")

CANTILEVER DEFLECTION:  
ALLOWABLE DEFL.(LL)= L/120 (0.19")  
CALCULATED VERT. DEFL.(LL) = L/ 999 (0.01")  
ALLOWABLE DEFL.(TL)= L/120 (0.19")  
CALCULATED VERT. DEFL.(TL) = L/ 999 (0.01")

CSI: TC=0.39/1.00 (B-C:1), BC=0.17/1.00 (E-F:1), WB=0.09/1.00 (A-H:1), SSI=0.21/1.00 (B-C:1)

DOL LUMBER=1.00 NAIL=1.00 LS BEND=1.00 COMP=1.00 SHEAR=1.00 TENS= 1.00

COMPANION LIVE LOAD FACTOR = 1.00

TRUSS PLATE MANUFACTURER IS NOT RESPONSIBLE FOR QUALITY CONTROL IN THE TRUSS MANUFACTURING PLANT .

NAIL VALUES

PLATE	GRIP(DRY)	SHEAR	SECTION
(PSI)	(PLI)	(PLI)	
MAX	MIN	MAX	MIN
MT20	650	371	1747
	788	1987	1873

PLATE PLACEMENT TOL. = 0.250 inches

PLATE ROTATION TOL. = 5.0 Deg.

JOB NAME <b>318396</b>	TRUSS NAME <b>H21</b>	QUANTITY	PLY <b>1</b>	JOB DESC. TRUSS DESC. <b>JT 45147</b>	DRWG NO. <b>E20035386</b>
---------------------------	--------------------------	----------	-----------------	--	------------------------------

Alpa Roof Truss, Maple Version 8.310 S Oct 29 2019 MiTek Industries, Inc. Tue Mar 24 17:21:17 2020 Page 1

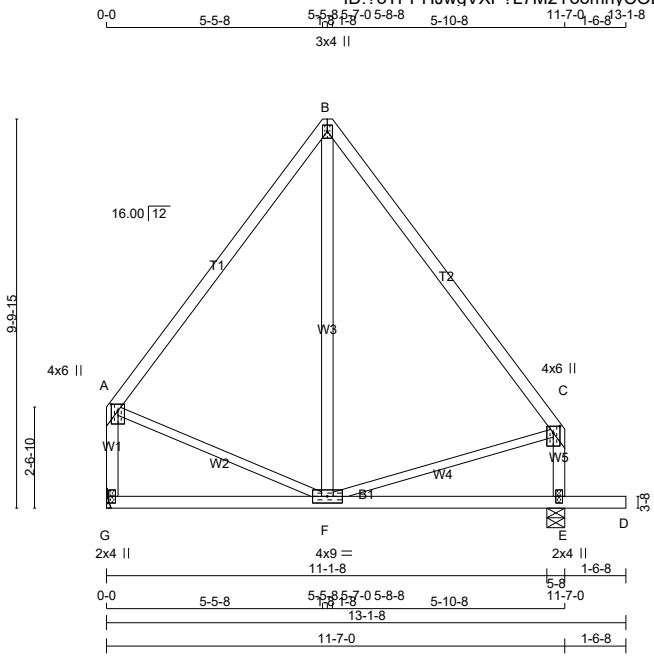

TOTAL WEIGHT = 62 lb [M][F]

**LUMBER**

N. L. G. A. RULES	CHORDS	SIZE	LUMBER	DESCR.
A - B	2x4	DRY	No.2	SPF
B - C	2x4	DRY	2100F 1.8E	SPF
G - A	2x4	DRY	No.2	SPF
E - C	2x4	DRY	No.2	SPF
G - D	2x4	DRY	No.2	SPF
ALL WEBS EXCEPT F - B	2x3	DRY	No.2	SPF
	2x4	DRY	No.2	SPF

DRY: SEASONED LUMBER.

**PLATES (table is in inches)**

JT TYPE	PLATES	W	LEN	Y	X
A	TMVW+p	MT20	4.0	6.0	2.00 2.00
B	TTW+p	MT20	3.0	4.0	
C	TMVW+p	MT20	4.0	6.0	2.00 2.00
E	BMV1+p	MT20	2.0	4.0	
F	BMWWW-t	MT20	4.0	9.0	
G	BMV1+p	MT20	2.0	4.0	

**DIMENSIONS, SUPPORTS AND LOADINGS SPECIFIED BY FABRICATOR TO BE VERIFIED BY BUILDING DESIGNER**

**BEARINGS**

JT	FACTORED GROSS REACTION	MAXIMUM FACTORED GROSS REACTION	INPUT BRG	REQRD BRG
	VERT	HORZ	DOWN	HORZ
G	559	0	559	0
E	707	0	707	0

A SUITABLE HANGER/MECHANICAL CONNECTION IS REQUIRED AT JOINT G. MINIMUM BEARING LENGTH AT JOINT G = 1-8.

**UNFACTORED REACTIONS**

JT	1ST LCASE	COMBINED	SNOW	LIVE	PERM.LIVE	WIND	DEAD	SOIL
G	398	243 / 0	0 / 0	0 / 0	0 / 0	0 / 0	155 / 0	0 / 0
E	504	308 / 0	0 / 0	0 / 0	0 / 0	0 / 0	197 / 0	0 / 0

BEARING MATERIAL TO BE SPF NO.2 OR BETTER AT JOINT(S) E

**BRACING**  
TOP CHORD TO BE SHEATHED OR MAX. PURLIN SPACING = 6.25 FT.  
MAX. UNBRACED BOTTOM CHORD LENGTH = 10.00 FT OR RIGID CEILING DIRECTLY APPLIED.

ALL PITCH BREAKS AND PERIMETER CORNER JOINTS MUST BE Laterally RESTRAINED.

**LOADING**  
TOTAL LOAD CASES: (4)

CHORDS				WEBS			
MEMB.	MAX. FACTORED FORCE (LBS)	FACTORED VERT. LOAD (PLF)	FACTORED LC1 MAX CSI (LC)	MAX. UNBRAC LENGTH	MEMB.	MAX. FACTORED FORCE (LBS)	MAX. FACTORED CSI (LC)
A-B	-293 / 0	-78.0	-78.0 0.31 (1)	6.25	A-F	0 / 189	0.04 (1)
B-C	-293 / 0	-78.0	-78.0 0.24 (1)	6.25	F-C	0 / 182	0.04 (1)
G-A	-520 / 0	0.0	0.0 0.07 (1)	7.81	F-B	0 / 101	0.02 (4)
E-C	-516 / 0	0.0	0.0 0.06 (1)	7.81			
G-F	0 / 0	-18.5	-18.5 0.18 (4)	10.00			
F-E	0 / 0	-18.5	-18.5 0.18 (4)	10.00			
E-D	0 / 0	-96.5	-96.5 0.16 (1)	10.00			

**DESIGN CRITERIA**

**SPECIFIED LOADS:**  
TOP CH. LL = 21.0 PSF  
DL = 6.0 PSF  
BOT CH. LL = 0.0 PSF  
DL = 7.4 PSF  
TOTAL LOAD = 34.4 PSF

**SPACING = 24.0 IN./C**

THIS TRUSS IS DESIGNED FOR RESIDENTIAL OR SMALL BUILDING REQUIREMENTS OF PART 9, NBCC 2015

THIS DESIGN COMPLIES WITH:  
- PART 9 OF BCBC 2018, ABC 2019  
- PART 9 OF OBC 2012 (2019 AMENDMENT)  
- CSA 086-14  
- TPIC 2014

(55 % OF 23.0 P.S.F. G.S.L. PLUS 8.4 P.S.F. RAIN LOAD) EQUALS 21.0 P.S.F. SPECIFIED ROOF LIVE LOAD

ALLOWABLE DEFL.(LL)= L/360 (0.39")  
CALCULATED VERT. DEFL.(LL) = L/ 999 (0.00")  
ALLOWABLE DEFL.(TL)= L/360 (0.39")  
CALCULATED VERT. DEFL.(TL) = L/ 999 (0.03")

CANTILEVER DEFLECTION:  
ALLOWABLE DEFL.(LL)= L/120 (0.19")  
CALCULATED VERT. DEFL.(LL) = L/ 999 (0.01")  
ALLOWABLE DEFL.(TL)= L/120 (0.19")  
CALCULATED VERT. DEFL.(TL) = L/ 999 (0.01")

CSI: TC=0.31/1.00 (A-B:1), BC=0.18/1.00 (F-G:4), WB=0.04/1.00 (A-F:1), SSI=0.12/1.00 (D-E:1)

DOL LUMBER=1.00 NAIL=1.00 LS BEND=1.10 COMP=1.10 SHEAR=1.10 TENS= 1.10

COMPANION LIVE LOAD FACTOR = 1.00

TRUSS PLATE MANUFACTURER IS NOT RESPONSIBLE FOR QUALITY CONTROL IN THE TRUSS MANUFACTURING PLANT.

**NAIL VALUES**

PLATE	GRIP(DRY)	SHEAR (PSI)	SECTION (PLI)
MT20	650	371	1747 788 1987 1873

PLATE PLACEMENT TOL. = 0.250 inches

PLATE ROTATION TOL. = 5.0 Deg.

JSI GRIP= 0.29 (A) (INPUT = 0.90 )  
JSI METAL= 0.15 (C) (INPUT = 1.00 )

LATERAL BRACE(S) SHOWN SHALL BE 2X4 SPF#2



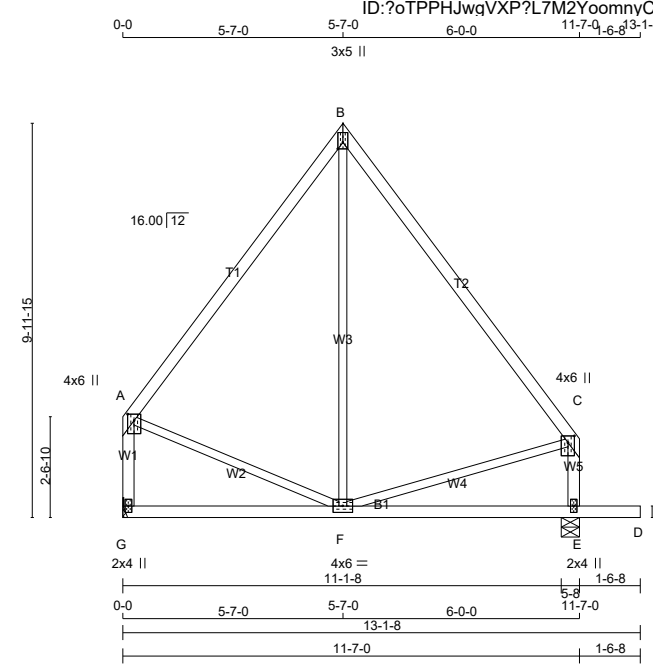

TOTAL WEIGHT = 2 X 59 = 118 lb

**LUMBER**

N. L. G. A. RULES	CHORDS	SIZE	LUMBER	DESCR.
A - B	2x4	DRY	No.2	SPF
B - C	2x4	DRY	2100F 1.8E	SPF
G - A	2x4	DRY	No.2	SPF
E - C	2x4	DRY	No.2	SPF
G - D	2x4	DRY	No.2	SPF

ALL WEBS 2x3 DRY No.2 SPF EXCEPT  
 DRY: SEASONED LUMBER.

**PLATES (table is in inches)**

JT	TYPE	PLATES	W	LEN	Y	X
A	TMVW+p	MT20	4.0	6.0	2.00	2.00
B	TTW+p	MT20	3.0	5.0	2.00	Edge
C	TMVW+p	MT20	4.0	6.0	2.00	2.00
E	BMV1+p	MT20	2.0	4.0		
F	BMWWW-t	MT20	4.0	6.0		
G	BMV1+p	MT20	2.0	4.0		

Edge - INDICATES REFERENCE CORNER OF PLATE TOUCHES EDGE OF CHORD.

LATERAL BRACE(S) SHOWN SHALL BE 2X4 SPF#2



**DIMENSIONS, SUPPORTS AND LOADINGS SPECIFIED BY FABRICATOR TO BE VERIFIED BY BUILDING DESIGNER**

**BEARINGS**

JT	FACTORED GROSS REACTION		MAXIMUM FACTORED GROSS REACTION		INPUT BRG	REQRD BRG
	VERT	HORZ	DOWN	HORZ		
G	559	0	559	0	0	MECHANICAL
E	707	0	707	0	0	5-8 1-8

A SUITABLE HANGER/MECHANICAL CONNECTION IS REQUIRED AT JOINT G. MINIMUM BEARING LENGTH AT JOINT G = 1-8.

**UNFACTORED REACTIONS**

JT	COMBINED	MAX./MIN. COMPONENT REACTIONS						
		1ST LCASE	SNOW	LIVE	PERM.LIVE	WIND	DEAD	SOIL
G	398	243 / 0	0 / 0	0 / 0	0 / 0	0 / 0	155 / 0	0 / 0
E	504	308 / 0	0 / 0	0 / 0	0 / 0	0 / 0	197 / 0	0 / 0

BEARING MATERIAL TO BE SPF NO.2 OR BETTER AT JOINT(S) E

**BRACING**  
 TOP CHORD TO BE SHEATHED OR MAX. PURLIN SPACING = 6.25 FT.  
 MAX. UNBRACED BOTTOM CHORD LENGTH = 10.00 FT OR RIGID CEILING DIRECTLY APPLIED.

ALL PITCH BREAKS AND PERIMETER CORNER JOINTS MUST BE Laterally RESTRAINED.

**LOADING**  
 TOTAL LOAD CASES: (4)

MEMB.	CHORDS		FACTORED		MAX. UNBRAC	WEBS		FACTORED	
	FORCE (LBS)	VERT. LOAD (PLF)	LOAD (PLF)	LC1 MAX CSI (LC)		MEMB. FORCE (LBS)	MAX. FORCE (LBS)	MAX. CSI (LC)	
FR-TO					LENGTH	FR-TO			
A-B	-293 / 0	-78.0	-78.0	0.31 (1)	6.25	F-B	0 / 101	0.03 (4)	
B-C	-293 / 0	-78.0	-78.0	0.24 (1)	6.25	A-F	0 / 189	0.04 (1)	
G-A	-520 / 0	0.0	0.0	0.07 (1)	7.81	F-C	0 / 182	0.04 (1)	
E-C	-516 / 0	0.0	0.0	0.06 (1)	7.81				
G-F	0 / 0	-18.5	-18.5	0.18 (4)	10.00				
F-E	0 / 0	-18.5	-18.5	0.18 (4)	10.00				
E-D	0 / 0	-96.5	-96.5	0.16 (1)	10.00				

**DESIGN CRITERIA**

**SPECIFIED LOADS:**  
 TOP CH. LL = 21.0 PSF  
 DL = 6.0 PSF  
 BOT CH. LL = 0.0 PSF  
 DL = 7.4 PSF  
 TOTAL LOAD = 34.4 PSF

**SPACING = 24.0 IN./C/C**

THIS TRUSS IS DESIGNED FOR RESIDENTIAL OR SMALL BUILDING REQUIREMENTS OF PART 9, NBCC 2015

THIS DESIGN COMPLIES WITH:  
 - PART 9 OF BCBC 2018, ABC 2019  
 - PART 9 OF OBC 2012 (2019 AMENDMENT)  
 - CSA 086-14  
 - TPIC 2014

(55 % OF 23.0 P.S.F. G.S.L. PLUS 8.4 P.S.F. RAIN LOAD) EQUALS 21.0 P.S.F. SPECIFIED ROOF LIVE LOAD

ALLOWABLE DEFL.(LL)= L/360 (0.39")  
 CALCULATED VERT. DEFL.(LL) = L/999 (0.00")  
 ALLOWABLE DEFL.(TL)= L/360 (0.39")  
 CALCULATED VERT. DEFL.(TL) = L/999 (0.03")

**CANTILEVER DEFLECTION:**  
 ALLOWABLE DEFL.(LL)= L/120 (0.19")  
 CALCULATED VERT. DEFL.(LL) = L/999 (0.01")  
 ALLOWABLE DEFL.(TL)= L/120 (0.19")  
 CALCULATED VERT. DEFL.(TL) = L/999 (0.01")

CSI: TC=0.31/1.00 (A-B:1), BC=0.18/1.00 (F-G:4), WB=0.04/1.00 (A-F:1), SSI=0.12/1.00 (D-E:1)

DOL LUMBER=1.00 NAIL=1.00 LS BEND=1.10 COMP=1.10 SHEAR=1.10 TENS= 1.10

COMPANION LIVE LOAD FACTOR = 1.00

TRUSS PLATE MANUFACTURER IS NOT RESPONSIBLE FOR QUALITY CONTROL IN THE TRUSS MANUFACTURING PLANT.

**NAIL VALUES**

PLATE GRIP(DRY)	SHEAR (PSI)	SECTION (PLI)	MAX MIN	MAX MIN	MAX MIN
MT20	650	371	1747	788	1987 1873

PLATE PLACEMENT TOL. = 0.250 inches

PLATE ROTATION TOL. = 5.0 Deg.

JSI GRIP= 0.29 (F) (INPUT = 0.90)  
 JSI METAL= 0.15 (C) (INPUT = 1.00)

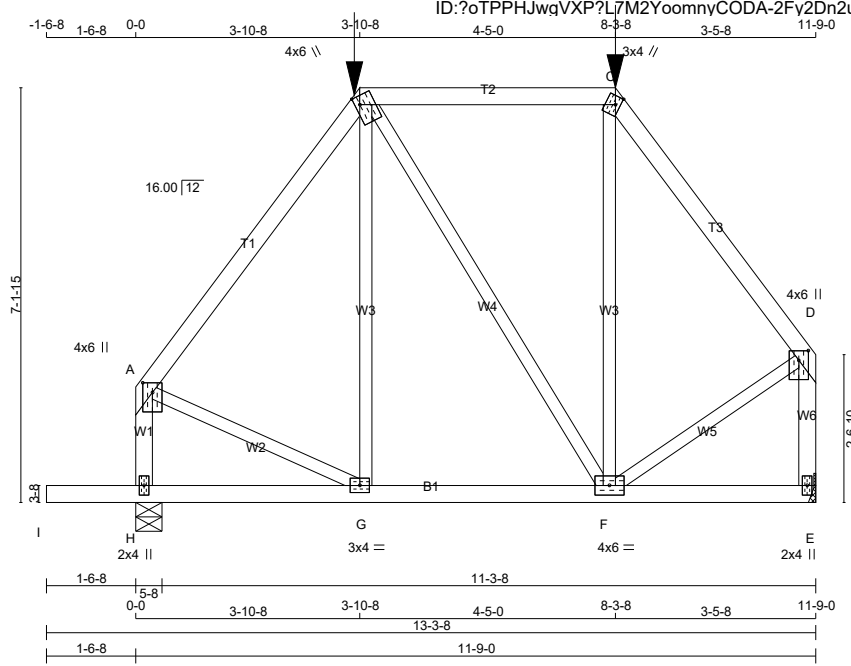

TOTAL WEIGHT = 63 lb [M]

**LUMBER**

N. L. G. A. RULES	CHORDS	SIZE	LUMBER	DESCR.
A - B	2x4	DRY	No.2	SPF
B - C	2x4	DRY	No.2	SPF
C - D	2x4	DRY	No.2	SPF
H - A	2x4	DRY	No.2	SPF
E - D	2x4	DRY	No.2	SPF
I - E	2x4	DRY	No.2	SPF
ALL WEBS EXCEPT	2x3	DRY	No.2	SPF

DRY: SEASONED LUMBER.

**PLATES (table is in inches)**

JT TYPE	PLATES	W	LEN	Y	X	
A	TMVW+p	MT20	4.0	6.0	2.00	2.00
B	TTWW+m	MT20	4.0	6.0	1.75	1.00
C	TTW+m	MT20	3.0	4.0	1.75	1.00
D	TMVW+p	MT20	4.0	6.0	2.00	2.00
E	BMV1+p	MT20	2.0	4.0		
F	BMWWW-t	MT20	4.0	6.0		
G	BMWW-t	MT20	3.0	4.0		
H	BMV1+p	MT20	2.0	4.0		

LATERAL BRACE(S) SHOWN SHALL BE 2X4 SPF#2



**DIMENSIONS, SUPPORTS AND LOADINGS SPECIFIED BY FABRICATOR TO BE VERIFIED BY BUILDING DESIGNER**

**BEARINGS**

JT	VERT	HORZ	GROSS REACTION	MAXIMUM FACTORED GROSS REACTION	INPUT BRG	REQRD BRG
E	816	0	816	0	0	MECHANICAL
H	956	0	956	0	0	5-8 1-8

A SUITABLE HANGER/MECHANICAL CONNECTION IS REQUIRED AT JOINT E. MINIMUM BEARING LENGTH AT JOINT E = 1-8.

**UNFACTORED REACTIONS**

JT	COMBINED	SNOW	LIVE	PERM.LIVE	WIND	DEAD	SOIL
E	582	353/0	0/0	0/0	0/0	229/0	0/0
H	682	413/0	0/0	0/0	0/0	269/0	0/0

BEARING MATERIAL TO BE SPF NO.2 OR BETTER AT JOINT(S) H

**BRACING**  
TOP CHORD TO BE SHEATHED OR MAX. PURLIN SPACING = 6.25 FT.  
MAX. UNBRACED BOTTOM CHORD LENGTH = 10.00 FT OR RIGID CEILING DIRECTLY APPLIED.

ALL PITCH BREAKS AND PERIMETER CORNER JOINTS MUST BE Laterally RESTRAINED.

**LOADING**  
TOTAL LOAD CASES: (4)

MEMB.	C H O R D S				W E B S			
	MAX. FORCE (LBS)	FACTORED VERT. LOAD (PLF)	LC1 MAX	MAX. CSI (LC)	MEMB. UNBRAC LENGTH	MAX. FORCE (LBS)	MAX. CSI (LC)	
FR-TO		FROM	TO		FR-TO			
A-B	-587/0	-78.0	-78.0	0.24 (1)	6.25	G-B	-18/84	0.03 (4)
B-C	-328/0	-114.5	-114.5	0.42 (1)	6.25	B-F	-41/0	0.06 (1)
C-D	-552/0	-78.0	-78.0	0.19 (1)	6.25	F-C	-51/65	0.05 (1)
H-A	-764/0	0.0	0.0	0.10 (1)	7.81	A-G	0/378	0.09 (1)
E-D	-778/0	0.0	0.0	0.11 (1)	7.81	F-D	0/385	0.10 (1)
I-H	0/0	-96.5	-96.5	0.17 (1)	10.00			
H-G	0/0	-27.2	-27.2	0.11 (4)	10.00			
G-F	0/350	-27.2	-27.2	0.15 (4)	10.00			
F-E	0/0	-27.2	-27.2	0.10 (4)	10.00			

**FACTORED CONCENTRATED LOADS (LBS)**

JT	LOC.	LC1	MAX-	MAX+	FACE	DIR.	TYPE	HEEL	CONN.
B	3-10-8	-120	-120	---	FRONT	VERT	TOTAL	---	C1
C	8-3-8	-107	-107	---	FRONT	VERT	TOTAL	---	C1

**CONNECTION REQUIREMENTS**

- C1:** A SUITABLE HANGER/MECHANICAL CONNECTION IS REQUIRED.

**DESIGN CRITERIA**

**SPECIFIED LOADS:**  
 TOP CH. LL = 21.0 PSF  
 LEFT SETBACK = 3-10-8  
 DL = 6.0 PSF  
 BOT CH. LL = 0.0 PSF  
 DL = 7.4 PSF  
 TOTAL LOAD = 34.4 PSF

**SPACING = 24.0 IN./C/C**

LOADING IN FLAT SECTION BASED ON A SLOPE OF 2.00/12 MINIMUM

GIRDER TYPE: CPrimeHip  
 LEFT SETBACK = 3-10-8  
 RIGHT SETBACK = 3-5-8  
 END SETBACK = 3-10-8  
 END WALL WIDTH = 0-0  
 CORNER FRAMING TYPE: CONVENTIONAL  
 END JACK TYPE: CONVENTIONAL  
 APPLIED TO FRONT SIDE  
 - ADDTL LOADS BASED ON 55 % OF GSL.

THIS TRUSS IS DESIGNED FOR RESIDENTIAL OR SMALL BUILDING REQUIREMENTS OF PART 9, NBCC 2015

THIS DESIGN COMPLIES WITH:  
 - PART 9 OF BCBC 2018, ABC 2019  
 - PART 9 OF OBC 2012 (2019 AMENDMENT)  
 - CSA 086-14  
 - TPIC 2014

(55 % OF 23.0 P.S.F. G.S.L. PLUS 8.4 P.S.F. RAIN LOAD) EQUALS 21.0 P.S.F. SPECIFIED ROOF LIVE LOAD

ALLOWABLE DEFL.(LL)= L/360 (0.39")  
 CALCULATED VERT. DEFL.(LL) = L/ 999 (0.00")  
 ALLOWABLE DEFL.(TL)= L/360 (0.39")  
 CALCULATED VERT. DEFL.(TL) = L/ 999 (0.01")

CANTILEVER DEFLECTION:  
 ALLOWABLE DEFL.(LL)= L/120 (0.19")  
 CALCULATED VERT. DEFL.(LL) = L/ 999 (0.01")  
 ALLOWABLE DEFL.(TL)= L/120 (0.19")  
 CALCULATED VERT. DEFL.(TL) = L/ 999 (0.01")

CSI: TC=0.42/1.00 (B-C:1), BC=0.17/1.00 (H-I:1), WB=0.10/1.00 (D-F:1), SSI=0.22/1.00 (B-C:1)

DOL LUMBER=1.00 NAIL=1.00 LS BEND=1.00  
 COMP=1.00 SHEAR=1.00 TENS= 1.00

COMPANION LIVE LOAD FACTOR = 1.00

TRUSS PLATE MANUFACTURER IS NOT RESPONSIBLE FOR QUALITY CONTROL IN THE TRUSS MANUFACTURING PLANT .

**NAIL VALUES**

PLATE	GRIP(DRY)	SHEAR	SECTION
(PSI)	(PLI)	(PLI)	
MAX	MIN	MAX	MIN
MT20	650	371	1747
	788	1987	1873

PLATE PLACEMENT TOL. = 0.250 inches

PLATE ROTATION TOL. = 5.0 Deg.

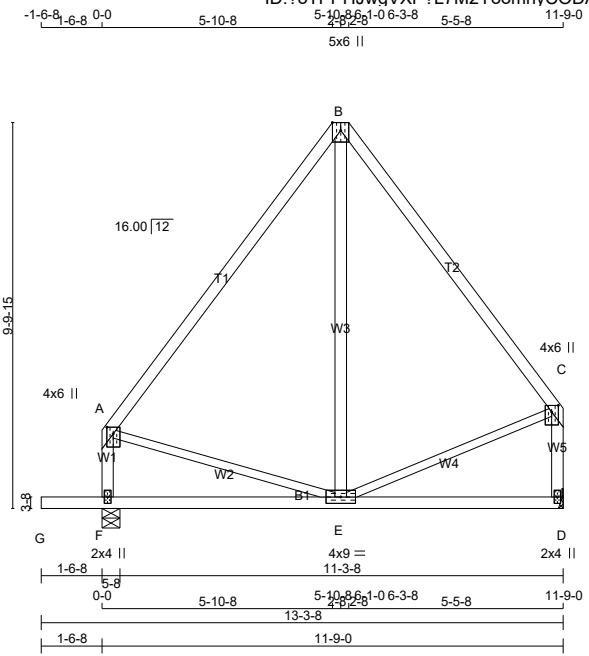

TOTAL WEIGHT = 62 lb

**LUMBER**

N. L. G. A. RULES	CHORDS	SIZE	LUMBER	DESCR.
A - B	2x4	DRY	2100F 1.8E	SPF
B - C	2x4	DRY	No.2	SPF
F - A	2x4	DRY	No.2	SPF
D - C	2x4	DRY	No.2	SPF
G - D	2x4	DRY	No.2	SPF
ALL WEBS EXCEPT E - B	2x3	DRY	No.2	SPF
	2x4	DRY	No.2	SPF

DRY: SEASONED LUMBER.

**PLATES (table is in inches)**

JT TYPE	PLATES	W	LEN	Y	X
A	TMVW+p	MT20	4.0	6.0	2.00 2.00
B	TMTMW+p	MT20	5.0	6.0	2.50 Edge
C	TMVW+p	MT20	4.0	6.0	2.00 2.00
D	BMV1+p	MT20	2.0	4.0	
E	BMWWW-t	MT20	4.0	9.0	
F	BMV1+p	MT20	2.0	4.0	

Edge - INDICATES REFERENCE CORNER OF PLATE TOUCHES EDGE OF CHORD.

**DIMENSIONS, SUPPORTS AND LOADINGS SPECIFIED BY FABRICATOR TO BE VERIFIED BY BUILDING DESIGNER**

**BEARINGS**

JT	FACTORED GROSS REACTION		MAXIMUM FACTORED GROSS REACTION		INPUT BRG	REQRD BRG
	VERT	HORZ	DOWN	HORZ		
D	567	0	567	0	MECHANICAL	
F	715	0	715	0	5-8	1-8

A SUITABLE HANGER/MECHANICAL CONNECTION IS REQUIRED AT JOINT D. MINIMUM BEARING LENGTH AT JOINT D = 1-8.

**UNFACTORED REACTIONS**

JT	1ST LCASE	SNOW	LIVE	PERM.LIVE	WIND	DEAD	SOIL
D	404	247 / 0	0 / 0	0 / 0	0 / 0	157 / 0	0 / 0
F	510	311 / 0	0 / 0	0 / 0	0 / 0	199 / 0	0 / 0

BEARING MATERIAL TO BE SPF NO.2 OR BETTER AT JOINT(S) F

**BRACING**  
TOP CHORD TO BE SHEATHED OR MAX. PURLIN SPACING = 6.25 FT.  
MAX. UNBRACED BOTTOM CHORD LENGTH = 10.00 FT OR RIGID CEILING DIRECTLY APPLIED.

ALL PITCH BREAKS AND PERIMETER CORNER JOINTS MUST BE Laterally RESTRAINED.

**LOADING**  
TOTAL LOAD CASES: (4)

MEMB.	MAX. FACTORED FORCE (LBS)	CHORDS			WEBS			
		VERT. LOAD (PLF)	LC1 MAX (PLF)	MAX. CSI (LC)	MEMB. FORCE (LBS)	MAX. FACTORED CSI (LC)	UNBRAC LENGTH	
A-B	-298 / 0	-78.0	-78.0	0.25 (1)	6.25	A-E	0 / 185	0.04 (1)
B-C	-298 / 0	-78.0	-78.0	0.32 (1)	6.25	E-C	0 / 192	0.04 (1)
F-A	-523 / 0	0.0	0.0	0.06 (1)	7.81	E-B	0 / 103	0.03 (4)
D-C	-528 / 0	0.0	0.0	0.07 (1)	7.81			
G-F	0 / 0	-96.5	-96.5	0.16 (1)	10.00			
F-E	0 / 0	-18.5	-18.5	0.18 (4)	10.00			
E-D	0 / 0	-18.5	-18.5	0.18 (4)	10.00			

**DESIGN CRITERIA**

**SPECIFIED LOADS:**  
TOP CH. LL = 21.0 PSF  
DL = 6.0 PSF  
BOT CH. LL = 0.0 PSF  
DL = 7.4 PSF  
TOTAL LOAD = 34.4 PSF

**SPACING = 24.0 IN./C/C**

THIS TRUSS IS DESIGNED FOR RESIDENTIAL OR SMALL BUILDING REQUIREMENTS OF PART 9, NBCC 2015

THIS DESIGN COMPLIES WITH:  
- PART 9 OF BCBC 2018, ABC 2019  
- PART 9 OF OBC 2012 (2019 AMENDMENT)  
- CSA 086-14  
- TPIC 2014

(55 % OF 23.0 P.S.F. G.S.L. PLUS 8.4 P.S.F. RAIN LOAD) EQUALS 21.0 P.S.F. SPECIFIED ROOF LIVE LOAD

ALLOWABLE DEFL.(LL)= L/360 (0.39")  
CALCULATED VERT. DEFL.(LL) = L/999 (0.00")  
ALLOWABLE DEFL.(TL)= L/360 (0.39")  
CALCULATED VERT. DEFL.(TL) = L/999 (0.03")

CANTILEVER DEFLECTION:  
ALLOWABLE DEFL.(LL)= L/120 (0.19")  
CALCULATED VERT. DEFL.(LL) = L/999 (0.01")  
ALLOWABLE DEFL.(TL)= L/120 (0.19")  
CALCULATED VERT. DEFL.(TL) = L/999 (0.01")

CSI: TC=0.32/1.00 (B-C:1), BC=0.18/1.00 (D-E:4), WB=0.04/1.00 (C-E:1), SSI=0.12/1.00 (F-G:1)

DOL LUMBER=1.00 NAIL=1.00 LS BEND=1.10 COMP=1.10 SHEAR=1.10 TENS= 1.10

COMPANION LIVE LOAD FACTOR = 1.00

TRUSS PLATE MANUFACTURER IS NOT RESPONSIBLE FOR QUALITY CONTROL IN THE TRUSS MANUFACTURING PLANT.

**NAIL VALUES**

PLATE GRIP(DRY)	SHEAR (PSI)	SECTION (PLI)
MAX MIN	MAX MIN	MAX MIN
MT20	650 371	1747 788 1987 1873

PLATE PLACEMENT TOL. = 0.250 inches

PLATE ROTATION TOL. = 5.0 Deg.

JSI GRIP= 0.29 (C) (INPUT = 0.90 )  
JSI METAL= 0.15 (A) (INPUT = 1.00 )

LATERAL BRACE(S) SHOWN SHALL BE 2X4 SPF#2



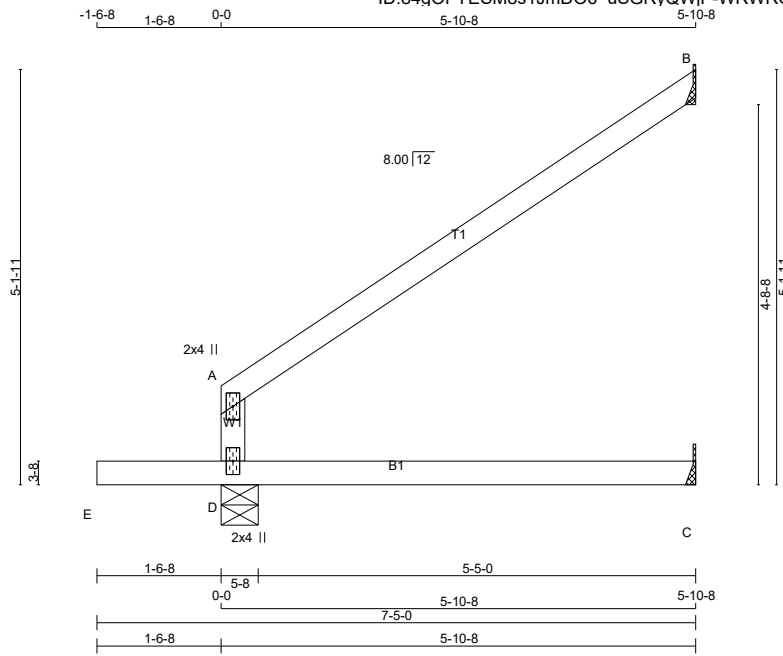

TOTAL WEIGHT = 15 X 18 = 264 lb [M]

**LUMBER**  
N. L. G. A. RULES

CHORDS	SIZE	DRY	LUMBER No.2	DESCR. SPF
D - A	2x4	DRY	No.2	SPF
A - B	2x4	DRY	No.2	SPF
E - C	2x4	DRY	No.2	SPF

DRY: SEASONED LUMBER.

**PLATES (table is in inches)**

JT	TYPE	PLATES	W	LEN	Y	X
A	TMV+p	MT20	2.0	4.0		
D	BMV1+p	MT20	2.0	4.0		

**DIMENSIONS, SUPPORTS AND LOADINGS SPECIFIED BY FABRICATOR TO BE VERIFIED BY BUILDING DESIGNER**

**BEARINGS**

JT	FACTORED GROSS REACTION		MAXIMUM FACTORED GROSS REACTION		INPUT BRG	REQRD BRG
	VERT	HORZ	DOWN	HORZ		
D	487	0	487	0	5-8	1-8
B	188	0	188	0	MECHANICAL	
C	41	0	46	0	MECHANICAL	

A SUITABLE HANGER/MECHANICAL CONNECTION IS REQUIRED AT JOINT B, C. MINIMUM BEARING LENGTH AT JOINT B = 1-8, JOINT C = 1-8.

BEVELED PLATE OR SHIM REQUIRED TO PROVIDE FULL BEARING SURFACE WITH TRUSS CHORD AT JT(S): B

**UNFACTORED REACTIONS**

JT	COMBINED	MAX./MIN. COMPONENT REACTIONS					
		1ST LCASE	SNOW	LIVE	PERM.LIVE	WIND	DEAD
D	348	210/0	0/0	0/0	0/0	137/0	0/0
B	130	101/0	0/0	0/0	0/0	29/0	0/0
C	33	0/0	0/0	0/0	0/0	33/0	0/0

BEARING MATERIAL TO BE SPF NO.2 OR BETTER AT JOINT(S) D

**BRACING**  
TOP CHORD TO BE SHEATHED OR MAX. PURLIN SPACING = 6.25 FT.  
MAX. UNBRACED BOTTOM CHORD LENGTH = 10.00 FT OR RIGID CEILING DIRECTLY APPLIED.

ALL PITCH BREAKS AND PERIMETER CORNER JOINTS MUST BE Laterally RESTRAINED.

**LOADING**  
TOTAL LOAD CASES: (4)

MEMB.	CHORDS				WEBS			
	MAX. FACTORED FORCE (LBS)	FACTORED VERT. LOAD (PLF)	LC1 MAX CSI (LC)	MAX UNBRAC LENGTH	MEMB. FORCE (LBS)	MAX FACTORED CSI (LC)	MEMB. FORCE (LBS)	MAX FACTORED CSI (LC)
FR-TO		FROM	TO		FR-TO			
D-A	-270/0	0.0	0.0	0.33 (1)	7.81			
A-B	-23/0	-78.0	-78.0	0.33 (1)	6.25			
E-D	0/0	-96.5	-96.5	0.16 (1)	10.00			
D-C	0/0	-18.5	-18.5	0.19 (4)	10.00			

**DESIGN CRITERIA**

**SPECIFIED LOADS:**

TOP CH.	LL	DL	PSF
		21.0	PSF
		6.0	PSF
BOT CH.	LL	DL	PSF
		0.0	PSF
		7.4	PSF
<b>TOTAL LOAD</b>		<b>34.4</b>	<b>PSF</b>

**SPACING = 24.0 IN./C/C**

THIS TRUSS IS DESIGNED FOR RESIDENTIAL OR SMALL BUILDING REQUIREMENTS OF PART 9, NBC2015

THIS DESIGN COMPLIES WITH:  
- PART 9 OF BCBC 2018, ABC 2019  
- PART 9 OF OBC 2012 (2019 AMENDMENT)  
- CSA 086-14  
- TPIC 2014

**DESIGN ASSUMPTIONS**  
-OVERHANG NOT TO BE ALTERED OR CUT OFF.

(55% OF 23.0 P.S.F. G.S.L. PLUS 8.4 P.S.F. RAIN LOAD) EQUALS 21.0 P.S.F. SPECIFIED ROOF LIVE LOAD

ALLOWABLE DEFL.(TL)= L/360 (0.20")  
CALCULATED VERT. DEFL.(TL) = L/999 (0.02")

CANTILEVER DEFLECTION:  
ALLOWABLE DEFL.(LL)= L/120 (0.19")  
CALCULATED VERT. DEFL.(LL) = L/999 (0.01")  
ALLOWABLE DEFL.(TL)= L/120 (0.19")  
CALCULATED VERT. DEFL.(TL) = L/999 (0.01")

CSI: TC=0.33/1.00 (A-D:1), BC=0.19/1.00 (C-D:4), WB=0.00/1.00 (n/a:0), SSI=0.18/1.00 (A-B:1)

DOL LUMBER=1.00 NAIL=1.00 LS BEND=1.10  
COMP=1.10 SHEAR=1.10 TENS= 1.10

COMPANION LIVE LOAD FACTOR = 1.00

AUTOSOLVE RIGHT HEEL ONLY

TRUSS PLATE MANUFACTURER IS NOT RESPONSIBLE FOR QUALITY CONTROL IN THE TRUSS MANUFACTURING PLANT .

**NAIL VALUES**

PLATE	GRIP(DRY)	SHEAR (PSI)	SECTION (PLI)
MT20	650	371	1747 788 1987 1873

PLATE PLACEMENT TOL. = 0.250 inches

PLATE ROTATION TOL. = 5.0 Deg.

JSI GRIP= 0.17 (A) (INPUT = 0.90 )  
JSI METAL= 0.14 (A) (INPUT = 1.00 )

LATERAL BRACE(S) SHOWN SHALL BE 2X4 SPF#2



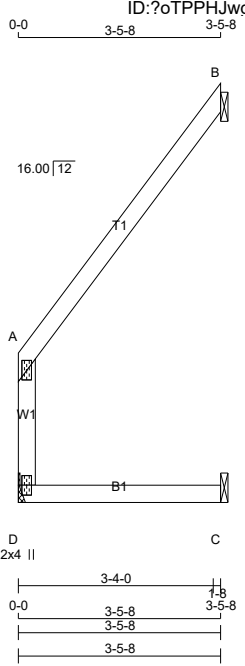

Scale = 1:39.4

TOTAL WEIGHT = 8 X 13 = 107 lb

**LUMBER**

N. L. G. A. RULES

CHORDS	SIZE	DRY	LUMBER	DESCR.
D - A	2x4	DRY	No.2	SPF
A - B	2x4	DRY	No.2	SPF
D - C	2x4	DRY	No.2	SPF

DRY: SEASONED LUMBER.

**PLATES (table is in inches)**

JT	TYPE	PLATES	W	LEN	Y	X
A	TMV+p	MT20	2.0	4.0		
D	BMV1+p	MT20	2.0	4.0		

**DIMENSIONS, SUPPORTS AND LOADINGS SPECIFIED BY FABRICATOR TO BE VERIFIED BY BUILDING DESIGNER**

**BEARINGS**

JT	FACTORED GROSS REACTION		MAXIMUM FACTORED GROSS REACTION		INPUT BRG	REQRD BRG
	VERT	HORZ	DOWN	HORZ		
D	167	0	167	0	MECHANICAL	
B	124	0	124	0	1-8	1-8
C	43	0	43	0	1-8	1-8

A SUITABLE HANGER/MECHANICAL CONNECTION IS REQUIRED AT JOINT D. MINIMUM BEARING LENGTH AT JOINT D = 1-8.

SEE MITEK STANDARD DETAIL B97791H FOR CONNECTION TO JOINT(S) B , C

**UNFACTORED REACTIONS**

JT	1ST LCASE	MAX./MIN. COMPONENT REACTIONS					
		COMBINED	SNOW	LIVE	PERM.LIVE	WIND	DEAD
D	119	73 / 0	0 / 0	0 / 0	0 / 0	46 / 0	0 / 0
B	86	66 / 0	0 / 0	0 / 0	0 / 0	20 / 0	0 / 0
C	33	7 / 0	0 / 0	0 / 0	0 / 0	26 / 0	0 / 0

**BRACING**  
TOP CHORD TO BE SHEATHED OR MAX. PURLIN SPACING = 10.00 FT.  
MAX. UNBRACED BOTTOM CHORD LENGTH = 10.00 FT OR RIGID CEILING DIRECTLY APPLIED.

ALL PITCH BREAKS AND PERIMETER CORNER JOINTS MUST BE Laterally RESTRAINED.

**LOADING**  
TOTAL LOAD CASES: (4)

MEMB.	CHORDS				WEBS			
	MAX. FACTORED FORCE (LBS)	FACTORED VERT. LOAD (PLF)	LC1 MAX (PLF)	LC2 MAX (PLF)	MEMB. UNBRAC LENGTH FR-TO	MAX. FACTORED FORCE (LBS)	MAX. FACTORED (PLF)	LC1 MAX (PLF)
D-A	-145 / 0	0.0	0.0	0.05 (1)	7.81			
A-B	-8 / 0	-78.0	-78.0	0.13 (1)	10.00			
D-C	0 / 0	-18.5	-18.5	0.07 (4)	10.00			

**DESIGN CRITERIA**

**SPECIFIED LOADS:**

TOP CH.	LL	DL
	21.0	6.0
BOT CH.	LL	DL
	0.0	7.4
<b>TOTAL LOAD</b>	<b>= 34.4</b>	<b>PSF</b>

**SPACING = 24.0 IN./C/C**

THIS TRUSS IS DESIGNED FOR RESIDENTIAL OR SMALL BUILDING REQUIREMENTS OF PART 9, NBCC 2015

THIS DESIGN COMPLIES WITH:  
- PART 9 OF BCBC 2018 , ABC 2019  
- PART 9 OF OBC 2012 (2019 AMENDMENT)  
- CSA 086-14  
- TPIC 2014

(55 % OF 23.0 P.S.F. G.S.L. PLUS 8.4 P.S.F. RAIN LOAD) EQUALS 21.0 P.S.F. SPECIFIED ROOF LIVE LOAD

ALLOWABLE DEFL.(LL)= L/360 (0.19")  
CALCULATED VERT. DEFL.(LL) = L/ 999 (0.00")  
ALLOWABLE DEFL.(TL)= L/360 (0.19")  
CALCULATED VERT. DEFL.(TL) = L/ 999 (0.01")

CSI: TC=0.13/1.00 (A-B:1) , BC=0.07/1.00 (C-D:4) , WB=0.00/1.00 (n/a:0) , SSI=0.07/1.00 (A-B:1)

DOL LUMBER=1.00 NAIL=1.00 LS BEND=1.10  
COMP=1.10 SHEAR=1.10 TENS= 1.10

COMPANION LIVE LOAD FACTOR = 1.00

TRUSS PLATE MANUFACTURER IS NOT RESPONSIBLE FOR QUALITY CONTROL IN THE TRUSS MANUFACTURING PLANT .

**NAIL VALUES**

PLATE	GRIP(DRY)	SHEAR (PSI)	SECTION (PLI)
MT20	650	371	1747 788 1987 1873

PLATE PLACEMENT TOL. = 0.250 inches

PLATE ROTATION TOL. = 5.0 Deg.

JSI GRIP= 0.12 (A) (INPUT = 0.90 )  
JSI METAL= 0.07 (A) (INPUT = 1.00 )

LATERAL BRACE(S) SHOWN SHALL BE 2X4 SPF#2





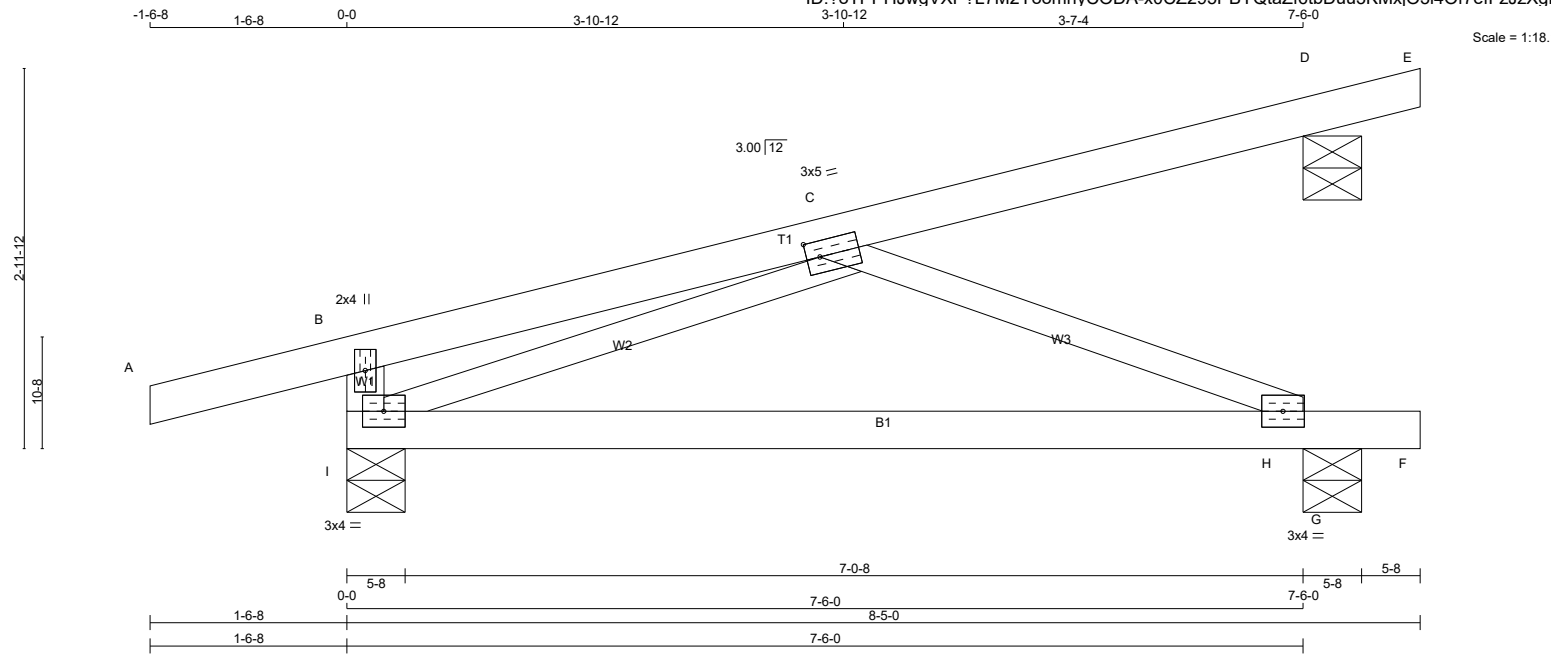

TOTAL WEIGHT = 6 X 28 = 169 lb

**LUMBER**

N. L. G. A. RULES

CHORDS	SIZE	DRY	LUMBER No.2	DESCR. SPF
A - E	2x4	DRY	No.2	SPF
I - B	2x4	DRY	No.2	SPF
I - F	2x4	DRY	No.2	SPF
ALL WEBS	2x3	DRY	No.2	SPF

DRY: SEASONED LUMBER.

**PLATES (table is in inches)**

JT TYPE	PLATES	W	LEN	Y	X
B	TMV+p	MT20	2.0	4.0	
C	TMWW-t	MT20	3.0	5.0	1.50 1.25
H	BMW-t	MT20	3.0	4.0	
I	BMVW1-t	MT20	3.0	4.0	

**DIMENSIONS, SUPPORTS AND LOADINGS SPECIFIED BY FABRICATOR TO BE VERIFIED BY BUILDING DESIGNER**

**BEARINGS**

JT	FACTORED GROSS REACTION		MAXIMUM FACTORED GROSS REACTION		INPUT BRG	REQRD BRG
	VERT	HORZ	DOWN	HORZ		
I	495	0	495	0	5-8	1-8
G	263	0	263	0	5-8	1-8
D	179	0	179	0	5-8	5-8

BEVELED PLATE OR SHIM REQUIRED TO PROVIDE FULL BEARING SURFACE WITH TRUSS CHORD AT JT(S): D

**UNFACTORED REACTIONS**

JT	1ST LCASE		MAX./MIN. COMPONENT REACTIONS		WIND	DEAD	SOIL
	COMBINED	SNOW	LIVE	PERM.LIVE			
JT	350	228 / 0	0 / 0	0 / 0	0 / 0	122 / 0	0 / 0
G	191	98 / 0	0 / 0	0 / 0	0 / 0	93 / 0	0 / 0
D	124	95 / 0	0 / 0	0 / 0	0 / 0	30 / 0	0 / 0

BEARING MATERIAL TO BE SPF NO.2 OR BETTER AT JOINT(S) I, G, D

**BRACING**  
 TOP CHORD TO BE SHEATHED OR MAX. PURLIN SPACING = 10.00 FT.  
 MAX. UNBRACED BOTTOM CHORD LENGTH = 10.00 FT OR RIGID CEILING DIRECTLY APPLIED.  
 ALL PITCH BREAKS AND PERIMETER CORNER JOINTS MUST BE LATERALLY RESTRAINED.

**LOADING**

TOTAL LOAD CASES: (4)

MEMB.	CHORDS				WEBS			
	MAX. FACTORED FORCE (LBS)	FACTORED VERT. LOAD (PLF)	LC1 MAX	CS1 (LC)	MAX. UNBRACED LENGTH	MEMB. FORCE (LBS)	FACTORED MAX CS1 (LC)	
A-B	0 / 15	-78.0	-78.0	0.13 (1)	10.00	I-C	-459 / 0	0.14 (1)
B-C	0 / 7	-78.0	-78.0	0.15 (1)	10.00	C-H	-466 / 0	0.14 (1)
C-D	-7 / 0	-78.0	-78.0	0.12 (1)	10.00			
D-E	-7 / 0	-78.0	-78.0	0.02 (1)	10.00			
I-B	-244 / 0	0.0	0.0	0.02 (1)	7.81			
I-H	0 / 426	-18.5	-18.5	0.35 (4)	10.00			
H-G	0 / 0	-18.5	-18.5	0.12 (1)	10.00			
G-F	0 / 0	-18.5	-18.5	0.01 (4)	10.00			

**DESIGN CRITERIA**

SPECIFIED LOADS:  
 TOP CH. LL = 21.0 PSF  
 DL = 6.0 PSF  
 BOT CH. LL = 0.0 PSF  
 DL = 7.4 PSF  
 TOTAL LOAD = 34.4 PSF

**SPACING = 24.0 IN. C/C**

THIS TRUSS IS DESIGNED FOR RESIDENTIAL OR SMALL BUILDING REQUIREMENTS OF PART 9, NBCC 2015

THIS DESIGN COMPLIES WITH:  
 - PART 9 OF BCBC 2018, ABC 2019  
 - PART 9 OF OBC 2012 (2019 AMENDMENT)  
 - CSA 086-14  
 - TPIC 2014

**DESIGN ASSUMPTIONS**  
 -OVERHANG NOT TO BE ALTERED OR CUT OFF.

(55% OF 23.0 P.S.F. G.S.L. PLUS 8.4 P.S.F. RAIN LOAD) EQUALS 21.0 P.S.F. SPECIFIED ROOF LIVE LOAD

ALLOWABLE DEFL.(LL)= L/360 (0.26")  
 CALCULATED VERT. DEFL.(LL) = L/ 999 (0.04")  
 ALLOWABLE DEFL.(TL)= L/360 (0.26")  
 CALCULATED VERT. DEFL.(TL) = L/ 434 (0.21")

CANTILEVER DEFLECTION:  
 ALLOWABLE DEFL.(LL)= L/120 (0.19")  
 CALCULATED VERT. DEFL.(LL) = L/ 538 (0.02")  
 ALLOWABLE DEFL.(TL)= L/120 (0.19")  
 CALCULATED VERT. DEFL.(TL) = L/ 120 (0.07")

CSI: TC=0.15/1.00 (B-C:1), BC=0.35/1.00 (H-I:4), WB=0.14/1.00 (C-H:1), SSI=0.20/1.00 (G-H:1)

DOL LUMBER=1.00 NAIL=1.00 LS BEND=1.10  
 COMP=1.10 SHEAR=1.10 TENS= 1.10

COMPANION LIVE LOAD FACTOR = 1.00

AUTOSOLVE HEELS OFF

TRUSS PLATE MANUFACTURER IS NOT RESPONSIBLE FOR QUALITY CONTROL IN THE TRUSS MANUFACTURING PLANT.

**NAIL VALUES**

PLATE	GRIP(DRY)	SHEAR (PSI)	SECTION (PLI)
MT20	650	371	1747 788 1987 1873

PLATE PLACEMENT TOL. = 0.250 inches

PLATE ROTATION TOL. = 5.0 Deg.

JSI GRIP= 0.62 (I) (INPUT = 0.90 )  
 JSI METAL= 0.16 (C) (INPUT = 1.00 )

LATERAL BRACE(S) SHOWN SHALL BE 2X4 SPF#2



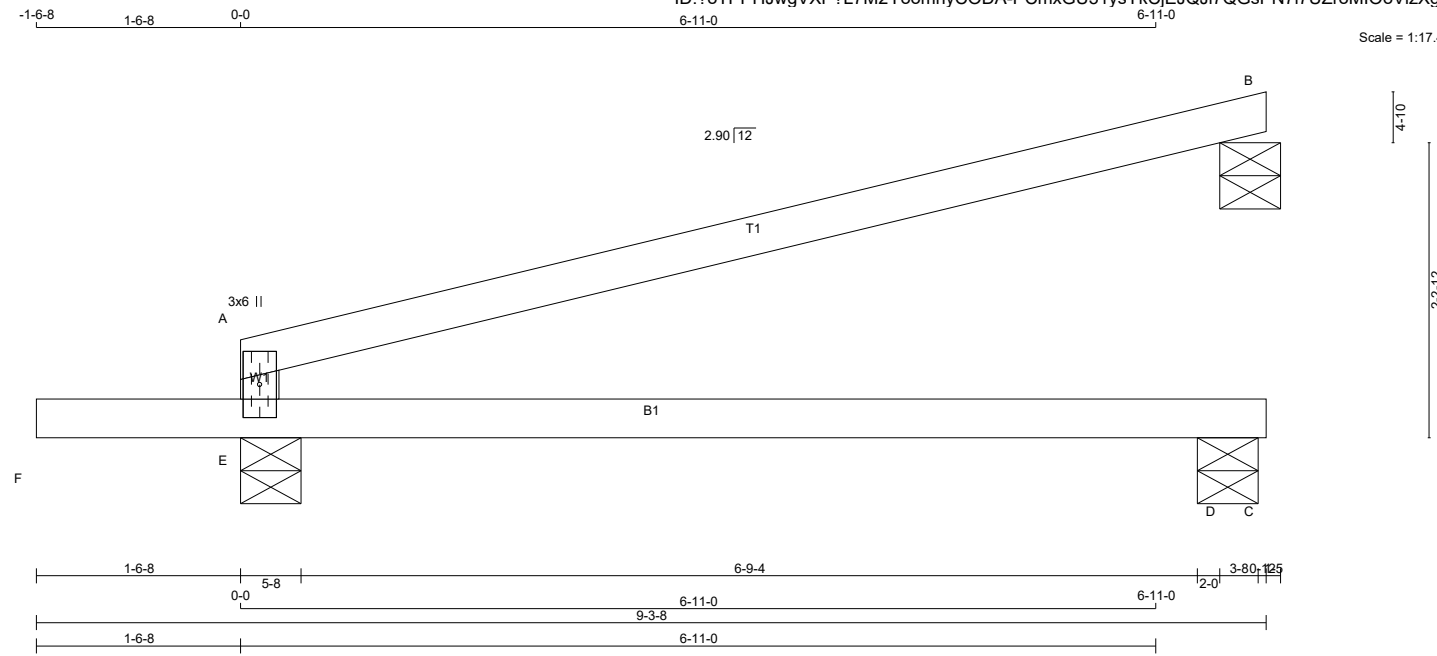

TOTAL WEIGHT = 7 X 20 = 140 lb

**LUMBER**

N. L. G. A. RULES	CHORDS	SIZE	DRY	LUMBER	No.2	DESCR.
A - B	2x4	DRY	No.2	SPF		
E - A	2x4	DRY	No.2	SPF		
F - C	2x4	DRY	No.2	SPF		

DRY: SEASONED LUMBER.

**PLATES (table is in inches)**

JT TYPE	PLATES	W	LEN	Y	X
A	TMBMV1+p	MT20	3.0	6.0	

**DIMENSIONS, SUPPORTS AND LOADINGS SPECIFIED BY FABRICATOR TO BE VERIFIED BY BUILDING DESIGNER**

**BEARINGS**

JT	FACTORED GROSS REACTION		MAXIMUM FACTORED GROSS REACTION		INPUT BRG	REQRD BRG
	VERT	HORZ	DOWN	HORZ		
B	237	0	237	0	5-8 (4-3)	4-3
E	602	0	602	0	5-8	1-8
D	57	0	64	0	5-8	1-8

VALUE IN PARENTHESIS INDICATES EFFECTIVE BEARING LENGTH

BEVELED PLATE OR SHIM REQUIRED TO PROVIDE FULL BEARING SURFACE WITH TRUSS CHORD AT JT(S): B

**UNFACTORED REACTIONS**

JT	COMBINED	MAX / MIN COMPONENT REACTIONS					SOIL
		SNOW	LIVE	PERM.LIVE	WIND	DEAD	
B	164	128 / 0	0 / 0	0 / 0	0 / 0	37 / 0	0 / 0
E	429	262 / 0	0 / 0	0 / 0	0 / 0	167 / 0	0 / 0
D	46	0 / 0	0 / 0	0 / 0	0 / 0	46 / 0	0 / 0

BEARING MATERIAL TO BE SPF NO.2 OR BETTER AT JOINT(S) B, E, D

**BRACING**  
 TOP CHORD TO BE SHEATHED OR MAX. PURLIN SPACING = 6.25 FT.  
 MAX. UNBRACED BOTTOM CHORD LENGTH = 10.00 FT OR RIGID CEILING DIRECTLY APPLIED.

ALL PITCH BREAKS AND PERIMETER CORNER JOINTS MUST BE LATERALLY RESTRAINED.

**LOADING**

TOTAL LOAD CASES: (4)

MEMB.	CHORDS				W E B S			
	MAX. FORCE (LBS)	FACTORED VERT. LOAD (PLF)	LC1	MAX	MAX. UNBRAC LENGTH	MEMB. FR-TO	MAX. FORCE (LBS)	FACTORED MAX CSI (LC)
FR-TO		FROM	TO					
A-B	-15 / 0	-78.0	-78.0	0.68 (1)	6.25			
E-A	-367 / 0	0.0	0.0	0.68 (1)	7.81			
F-E	0 / 0	-96.5	-96.5	0.16 (1)	10.00			
E-D	0 / 0	-18.5	-18.5	0.30 (4)	10.00			
D-C	0 / 0	-18.5	-18.5	0.00 (4)	10.00			

**DESIGN CRITERIA**

SPECIFIED LOADS:

TOP CH.	LL	=	21.0	PSF
	DL	=	6.0	PSF
BOT CH.	LL	=	0.0	PSF
	DL	=	7.4	PSF
TOTAL LOAD		=	34.4	PSF

**SPACING = 24.0 IN. C/C**

THIS TRUSS IS DESIGNED FOR RESIDENTIAL OR SMALL BUILDING REQUIREMENTS OF PART 9, NBC 2015

THIS DESIGN COMPLIES WITH:  
 - PART 9 OF BCBC 2018, ABC 2019  
 - PART 9 OF OBC 2012 (2019 AMENDMENT)  
 - CSA 086-14  
 - TPIC 2014

DESIGN ASSUMPTIONS  
 - OVERHANG NOT TO BE ALTERED OR CUT OFF.

(55% OF 23.0 P.S.F. G.S.L. PLUS 8.4 P.S.F. RAIN LOAD) EQUALS 21.0 P.S.F. SPECIFIED ROOF LIVE LOAD

ALLOWABLE DEFL.(TL)= L/360 (0.25")  
 CALCULATED VERT. DEFL.(TL) = L/999 (0.06")

CANTILEVER DEFLECTION:  
 ALLOWABLE DEFL.(LL)= L/120 (0.19")  
 CALCULATED VERT. DEFL.(LL) = L/999 (0.01")  
 ALLOWABLE DEFL.(TL)= L/120 (0.19")  
 CALCULATED VERT. DEFL.(TL) = L/999 (0.01")

CSI: TC=0.68/1.00 (A-E:1), BC=0.30/1.00 (D-E:4), WB=0.00/1.00 (n/a:0), SSI=0.28/1.00 (A-B:1)

DOL LUMBER=1.00 NAIL=1.00 LS BEND=1.10  
 COMP=1.10 SHEAR=1.10 TENS= 1.10

COMPANION LIVE LOAD FACTOR = 1.00

AUTOSOLVE RIGHT HEEL ONLY

TRUSS PLATE MANUFACTURER IS NOT RESPONSIBLE FOR QUALITY CONTROL IN THE TRUSS MANUFACTURING PLANT .

NAIL VALUES

PLATE	GRIP(DRY)	SHEAR (PSI)	SECTION (PLI)
MT20	650	371	1747 788 1987 1873

PLATE PLACEMENT TOL. = 0.250 inches

PLATE ROTATION TOL. = 5.0 Deg.

JSI GRIP= 0.15 (A) (INPUT = 0.90 )  
 JSI METAL= 0.05 (A) (INPUT = 1.00 )

LATERAL BRACE(S) SHOWN SHALL BE 2X4 SPF#2



December 18, 2019

**Re: Expiration Date for Technical Bulletins Extended to 4/1/2020**

Please be advised that the expiration date of the Technical Bulletins listed below has been extended until April 1, 2020.

T-SPECCP17	T-SPECH17	T-SPECDSHGUS17R
T-SPECHGUS17-R	T-SPECHHUS17-R	T-SPECHUS17
T-SPECLF17	T-SPECLT17	T-SPECLU17
T-SPECCLUL17	T-SPECLUS17	T-SPECSUR17
T-SPECTBE17	T-SPECTC17	T-SPECTHGB17
T-SPECTHGBHV17	T-SPECTHGQ17	T-SPECTHGW17
T-SPECLSULSSU17	T-SPECHTHGQ17	T-SPECSTHGQ17

Should you have any questions or concerns regarding the above, please contact me at your convenience.

Sincerely,



Brent Bunting, P.Eng.  
Simpson Strong-Tie Canada, Ltd.



# LUS – Double Shear Joist Hangers

All LUS hangers have double shear nailing. This patented innovation distributes the load through two points on each joist nail for greater strength. It also allows the use of fewer nails, faster installation and the use of common nails for all connections.

**Material:** 18 gauge

**Finish:** G90 galvanized

**Design:**

- Factored resistances are in accordance with CSA O86-14.
- Uplift resistances have been increased 15%. No further increase is permitted.
- Wood shear is not considered in the factored resistances given. The specifier must ensure that the joist and header capacities are capable of withstanding these loads.

**Installation:**

- Use all specified fasteners.
- Nails: 16d = 0.162" dia. x 3½" long common wire, 10d = 0.148" x 3" long common wire.
- Double shear nails must be driven at an angle through the joist or truss into the header to achieve the table loads.
- Not designed for welded or nailer applications.

**Options:**

- These hangers cannot be modified

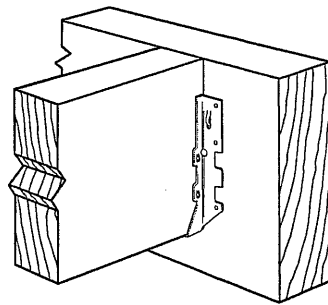

Typical LUS Installation

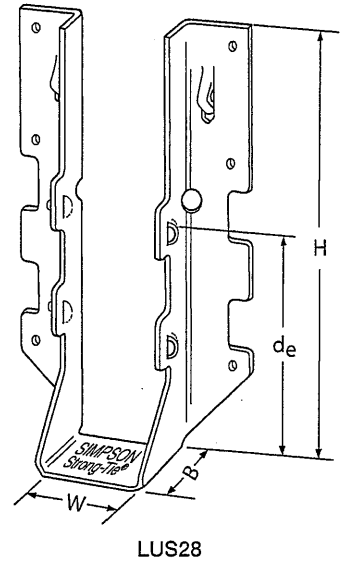

Model No.	Ga.	Dimensions (in.)				Fasteners		Factored Resistance (lb.)			
		W	H	B	d <sub>e</sub> <sup>1</sup>	Face	Joist	D.Fir-L		S-P-F	
								Uplift	Normal	Uplift	Normal
LUS24	18	1 9/16	3 3/8	1 3/4	1 15/16	(4) 10d	(2) 10d	710	1630	645	1155
LUS24-2	18	3 1/8	3 3/8	2	1 13/16	(4) 16d	(2) 16d	835	2020	590	1435
LUS26	18	1 9/16	4 3/4	1 3/4	3 5/8	(4) 10d	(4) 10d	1420	2170	1290	1630
LUS26-2	18	3 1/8	4 7/8	2	4	(4) 16d	(4) 16d	1720	2595	1545	1920
LUS26-3	18	4 5/8	4 3/16	2	3 1/4	(4) 16d	(4) 16d	1720	2595	1545	2340
LUS28	18	1 9/16	6 5/8	1 3/4	3 3/4	(6) 10d	(6) 10d	1420	2520	1290	1790
LUS28-2	18	3 1/8	7	2	4	(6) 16d	(4) 16d	1720	3325	1545	2575
LUS28-3	18	4 5/8	6 1/4	2	3 1/4	(6) 16d	(4) 16d	1720	3325	1545	2375
LUS210	18	1 9/16	7 13/16	1 3/4	3 7/8	(8) 10d	(4) 10d	1420	2785	1290	2210
LUS210-2	18	3 1/8	9	2	6	(8) 16d	(6) 16d	2580	4500	2320	3195
LUS210-3	18	4 5/8	8 3/16	2	5 1/4	(8) 16d	(6) 16d	2580	3345	2320	2375

1. d<sub>e</sub> is the distance from the seat of the hanger to the highest joist nail.

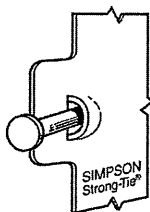

Dome Double Shear Nailing prevents tabs breaking off (available on some models).  
U.S. Patent 5,603,580

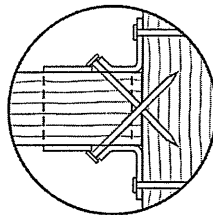

Double Shear Nailing Top View.

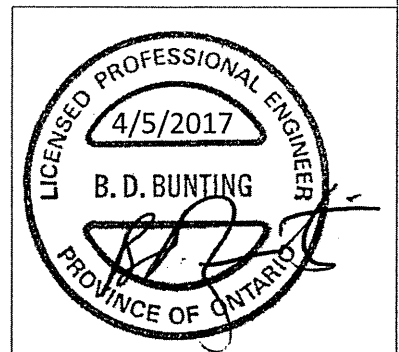

LIMIT STATES DESIGN

This technical bulletin is effective until June 30, 2019, and reflects information available as of March 1, 2017. This information is updated periodically and should not be relied upon after June 30, 2019. Contact Simpson Strong-Tie for current information and limited warranty or see strongtie.com.

© 2017 Simpson Strong-Tie Company Inc.

T-SPECLUS17 3/17 exp. 6/19

(800) 999-5099  
strongtie.com

# HHUS – Double Shear Joist Hangers

All HHUS hangers have double shear nailing. This patented innovation distributes the load through two points on each joist nail for greater strength. It also allows the use of fewer nails, faster installation and the use of common nails for all connections. Do not bend or remove tabs.

**Material:** 14 gauge

**Finish:** G90 galvanized

**Design:**

- Factored resistances are in accordance with CSA O86-14.
- Uplift resistances have been increased 15%. No further increase is permitted.
- Wood shear is not considered in the factored resistances given. The specifier must ensure that the joist and header capacities are capable of withstanding these loads.

**Installation:**

- Use all specified fasteners
- Nails: 16d = 0.162" dia. x 3 1/2" long common wire
- Double shear nails must be driven at an angle through the joist or truss into the header to achieve the table loads
- Not designed for welded or nailer applications

**Options:**

- See current catalogue for options

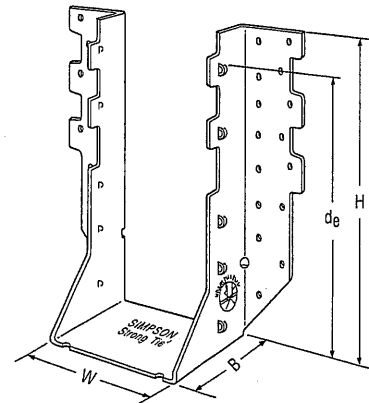

HHUS410

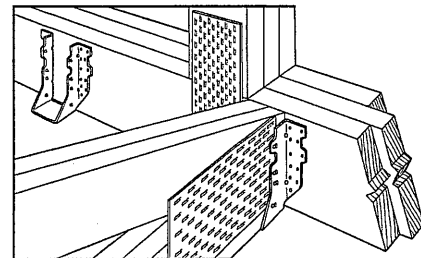

Typical HHUS Installation  
(Truss Designer to provide fastener quantity for connecting multiple members together)

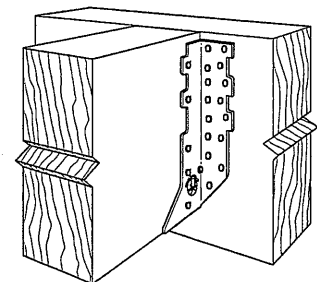

Typical HHUS Installation

Model No.	Ga.	Dimensions (in.)				Fasteners		Factored Resistance (lb.)			
		W	H	B	d <sub>b</sub> <sup>1</sup>	Face	Joist	D.Fir-L		S-P-F	
								Uplift (K <sub>p</sub> =1.15)	Normal (K <sub>p</sub> =1.00)	Uplift (K <sub>p</sub> =1.15)	Normal (K <sub>p</sub> =1.00)
HHUS26-2	14	3 5/16	5 13/16	3	3 15/16	(14) 16d	(6) 16d	2850	7335	2065	5205
HHUS28-2	14	3 5/16	7 7/32	3	6 5/32	(22) 16d	(8) 16d	3765	8940	2675	6345
HHUS210-2	14	3 5/16	9 3/32	3	8	(30) 16d	(10) 16d	4745	9660	4310	7000
HHUS210-3	14	4 11/16	9	3	7 15/16	(30) 16d	(10) 16d	4745	10545	4310	7485
HHUS210-4	14	6 1/8	8 29/32	3	7 27/32	(30) 16d	(10) 16d	4745	10545	4310	7485
HHUS46	14	3 5/8	5 13/32	3	3 15/16	(14) 16d	(6) 16d	2540	7335	2065	5205
HHUS48	14	3 5/8	7 1/8	3	6 1/8	(22) 16d	(8) 16d	3765	8945	2267	6345
HHUS410	14	3 5/8	9	3	8	(30) 16d	(10) 16d	4745	9855	4310	7000
HHUS5.50/10	14	5 1/2	9	3	8	(30) 16d	(10) 16d	4745	10545	4310	7485
HHUS7.25/10	14	7 1/4	9	3 5/16	7 29/32	(30) 16d	(10) 16d	4745	10770	4310	7650

1. d<sub>b</sub> is the distance from the seat of the hanger to the highest joist nail.

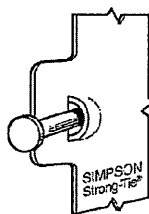

Dome Double Shear Nailing prevents tabs breaking off (available on some models).

U.S. Patent 5,603,580

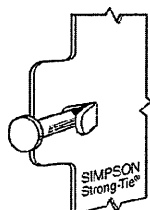

Double Shear Nailing Side View. Do not bend tab back.

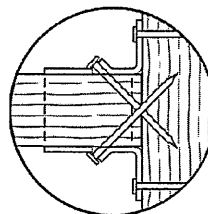

Double Shear Nailing Top View.



LIMIT STATES DESIGN

This technical bulletin is effective until June 30, 2019, and reflects information available as of March 1, 2017. This information is updated periodically and should not be relied upon after June 30, 2019. Contact Simpson Strong-Tie for current information and limited warranty or see strongtie.com

© 2017 Simpson Strong-Tie Company Inc.

T-SPECHHUS17 3/17 exp. 6/19

(800) 999-5099  
strongtie.com

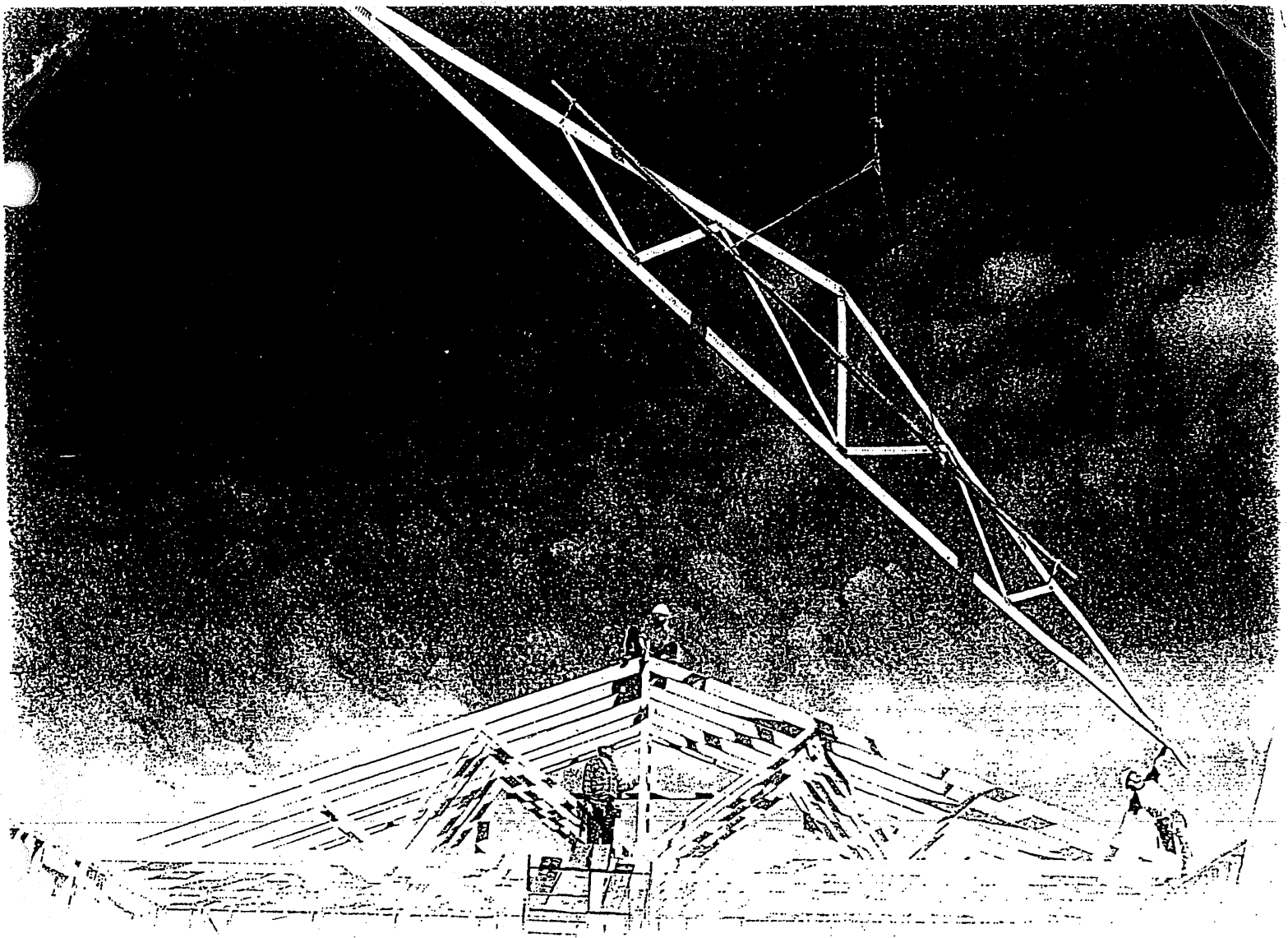

# **Wood Truss Installation**

**A Guide to proper handling, erecting and bracing  
metal plate connected wood trusses**

# Table of Content

	Warning.....	4
<b>1</b>	Unloading & Lifting.....	5
<b>2</b>	Job Site Handling.....	5
<b>3</b>	Hoisting.....	6
<b>4</b>	Beginning the Erection Process.....	7
<b>5</b>	Erection Tolerance.....	8
<b>6</b>	Bracing.....	8
<b>7</b>	Bracing Requirements for 3 Planes of Roof.....	9
<b>8</b>	Stacking Materials.....	10
	Caution Notes.....	11

# Warning

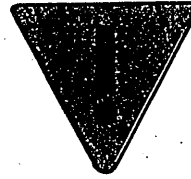

## General

Familiarity with the Construction Design Documents, the Truss Design Drawings, and Truss Placement Plans (if required by the Construction Design Documents) is required to properly erect, brace, and connect the trusses to the building system.

All of the care and quality involved in the design and manufacture of wood trusses can be jeopardized if the trusses are not properly handled, erected, and braced.

**The consequences of improper handling, erecting, and bracing may be a collapse of the structure, which at best is a substantial loss of time and materials, and at worst is a loss of life. The majority of truss accidents occur during truss installation and not as a result of improper design or manufacture.**

Prior to truss erection, the builder/erector shall meet with the erection crew for a safety and planning meeting, making sure each crew member understands his or her roles and responsibilities during the erection process.

## Temporary Erection Bracing

**Trusses are not marked in any way to identify the frequency, or location of temporary erection bracing.**

All temporary bracing shall comply with the latest edition of *Commentary and Recommendations for Handling, Installing & Bracing Metal Plate Connected Wood Trusses* (HIB), published by the Truss Plate Institute, and/or as specified in the Construction Design Documents prepared by the building designer.

## Permanent Truss Bracing

Permanent bracing for the roof or floor trusses is the responsibility of the building designer and should be shown on the Construction Design Documents. Permanent bracing locations for individual compression members of a wood truss are shown on the Truss Design Drawings, and shall be installed by the building or erection contractor. This bracing is needed for the proper performance of individual trusses within the roof or floor system. The design and connection of the bracing to the truss and then to the overall building system is the responsibility of the building designer, and is in addition to the permanent bracing plan, which is also specified by the building designer.

## Special Design Requirements

Special design requirements, such as wind bracing, portal bracing, seismic bracing, diaphragms, shear walls, or other load transfer elements and their connections to wood trusses must be considered separately by the building designer, who shall determine size, location, and method of connections for all bracing as needed to resist these forces.



# 1 Unloading & Lifting

## Never handle trusses flat

Beginning with the unloading process, and throughout all phases of construction, care must be taken to avoid lateral bending of trusses, which can cause damage to the lumber and metal connector plates at the joints.



**Avoid lateral bending**

- Use special care in windy weather.
- If using a crane within 10 feet of an electric line, contact the local power company.
- If using a crane within 5 miles of an airport, contact the airport 30 days prior to erection to learn about any safety regulations that must be followed.

# 2 Job Site Handling

Spreader bar for larger trusses

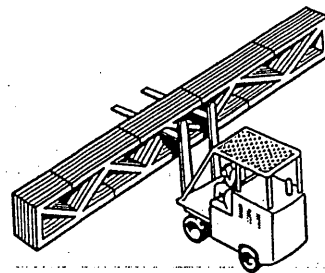
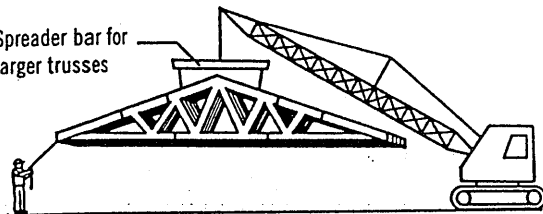

## All trusses should be picked up at the top chords in a vertical position only

Proper banding and smooth ground allow for unloading of trusses without damage. This should be done as close to the building site as possible to minimize handling. Do not break banding until installation begins. Hand erection of trusses is allowed, provided excessive lateral bending is prevented.

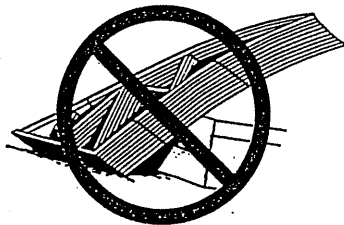

## Do not store unbraced bundles upright

If trusses are stored vertically they shall be braced in a manner that will prevent tipping or topping. Generally cutting of the banding is done just prior to installation.

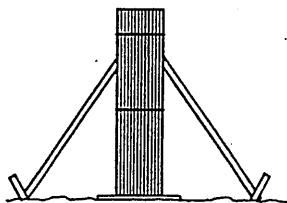

## Do not store on uneven ground

If trusses are stored horizontally, blocking should be used on eight to ten foot centers, or as required, to minimize lateral bending and moisture gain.

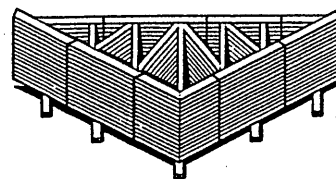

## Care should be exercised when removing banding to avoid damaging trusses.

During long term storage, trusses shall be protected from the environment in a manner that provides for adequate ventilation of the trusses. If tarpaulins or other material is used, the ends shall be left open for ventilation. Plastic is not recommended, since it can trap moisture.

# 3 Hoisting

All trusses that are erected one at a time shall be held safely in position by the erection equipment until such time as all necessary bracing has been installed and the ends of the trusses are securely fastened to the building.



Avoid lateral bending

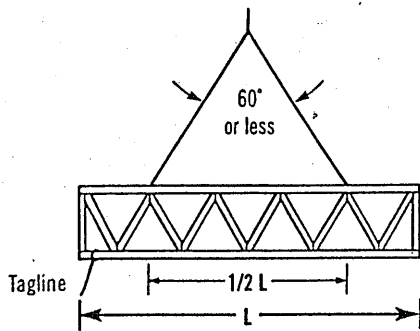

$L \leq 30'$

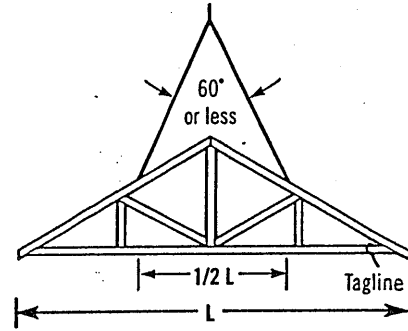

Truss sling is acceptable where these criteria are met.

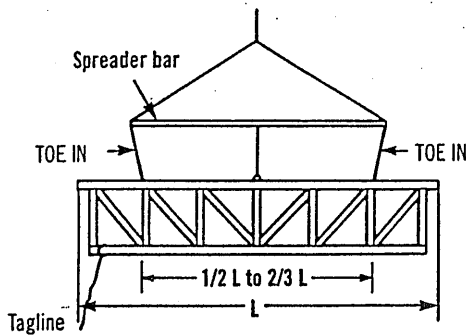

$30' < L \leq 60'$

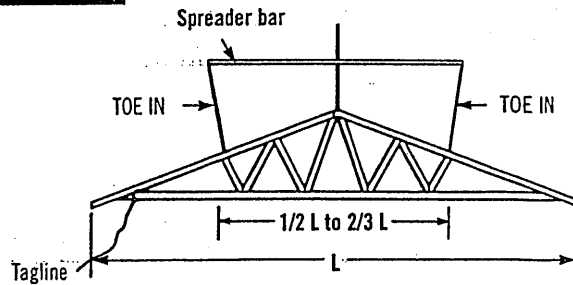

Use spreader bar in all other cases. It should be noted that the lines from the ends of the spreader bar "TOE IN"; if these lines should "TOE OUT" the truss may fold in half.

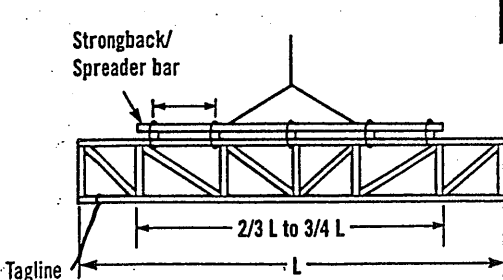

$L > 60'$

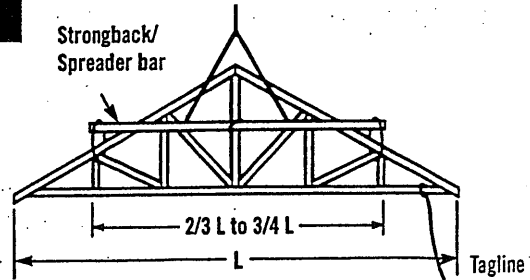

For lifting trusses with spans in excess of 60 feet, it is recommended that a strongback/spreader bar be used as illustrated. The strongback/spreader bar should be attached to the top chord and web members at intervals of approximately 10 feet. Further, the strongback/spreader bar should be at or above the mid-height of the truss to prevent overturning. The strongback/spreader bar can be of any material with sufficient strength to safely carry the weight of the truss and sufficient rigidity to adequately resist bending of the truss.

# 4 Beginning the Erection Process

It is important for the builder or erection contractor to provide substantial bracing for the first truss erected. The two or more trusses making up the rest of the first set are tied to and rely upon the first truss for stability. Likewise, after this first set of trusses is adequately cross-braced, the remaining trusses installed rely upon this first set for stability. Thus, the performance of the truss bracing system depends to a great extent on how well the first group of trusses is braced.

## Ground Brace - Exterior

One satisfactory method ties the first unit of trusses off to a series of braces that are attached to a stake driven into the ground and securely anchored. The ground brace itself should be supported as shown below or it is apt to buckle. Additional ground braces in the opposite direction, inside the building, are also recommended.

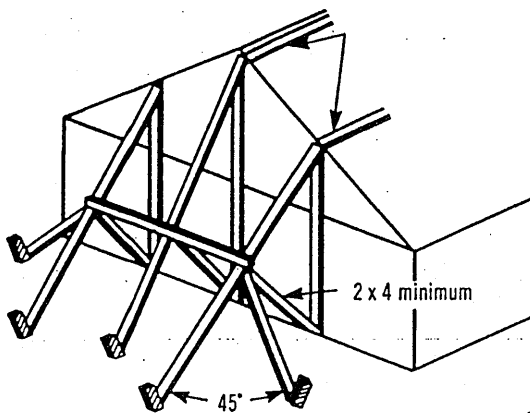

Note: Locate ground braces for first truss directly in line with all rows of top chord continuous lateral bracing (either temporary or permanent).

## Ground Brace - Interior

Another satisfactory method where height of building or ground conditions prohibit bracing from the exterior is to tie the first truss rigidly in place from the interior at the floor level, provided the floor is substantially completed and capable of supporting the ground bracing forces. Securely fasten the first truss to the middle of the building. Brace the bracing similar to exterior ground bracing shown at left. Set trusses from the middle toward the end of the building. Properly cross-brace the first set of trusses before removing floor braces and setting remaining trusses.

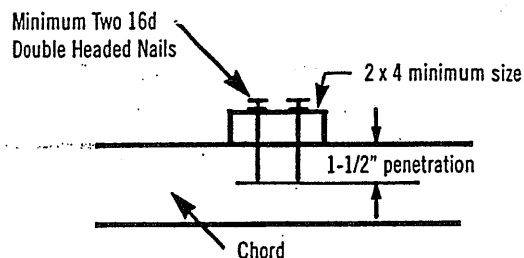
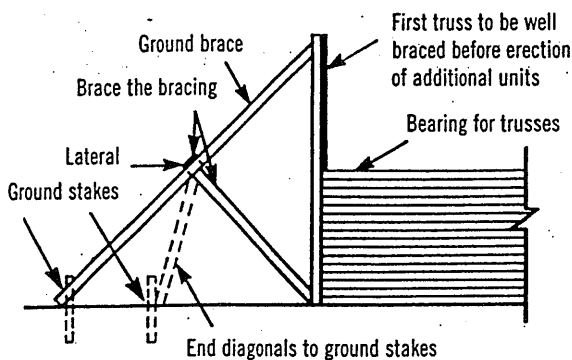
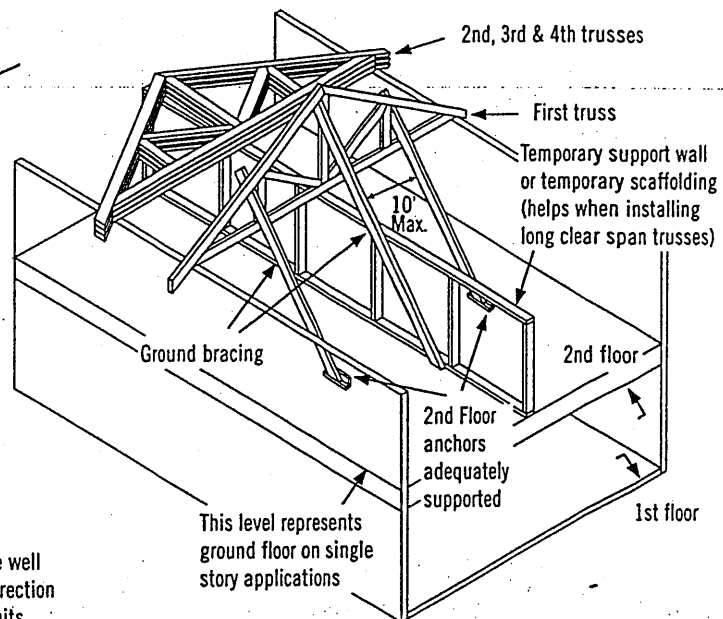

**Inadequate size of bracing material or inadequate fastening is a major cause of erection dominoing.**

# 5 Erection Tolerance

Complying with erection tolerances is critical to achieving an acceptable roof or floor line, and to accomplishing effective bracing. Setting trusses within tolerance the first time will prevent the need for the hazardous practice of respacing or adjusting trusses when roof sheathing or roof purlins are installed. Trusses leaning or bowing can cause nails to miss the top chords when sheathing is applied, and create cumulative stresses on the bracing, which is a frequent cause of dominoing.

**When sheathing, make sure nails are driven into the top chord of the trusses.**

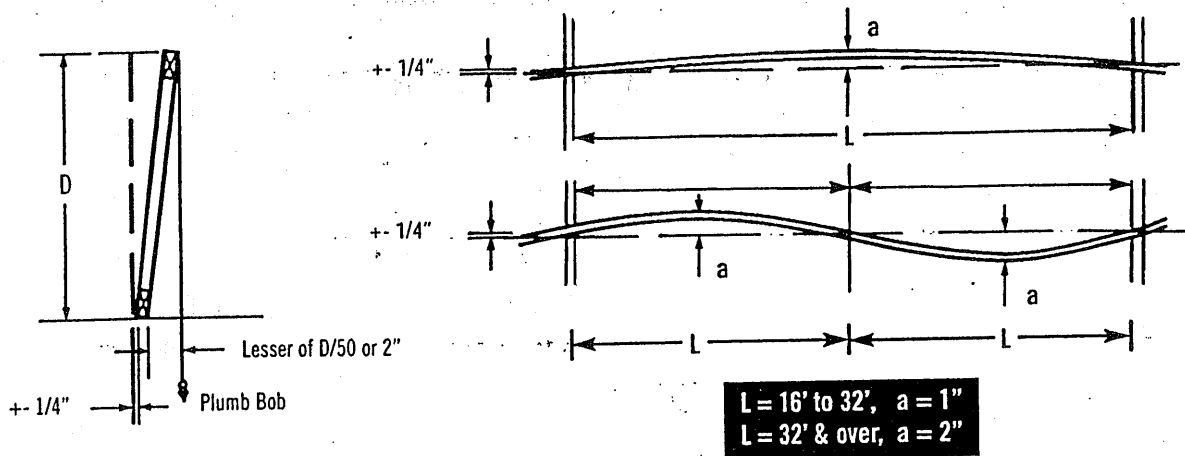

# 6 Bracing

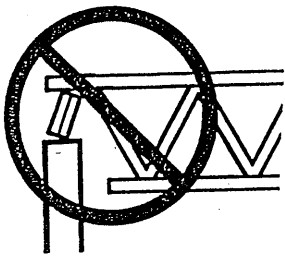

**Do not install trusses on temporarily connected supports**

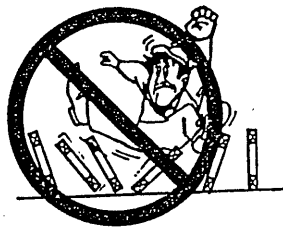

**Do not walk on unbraced trusses**



**Do not walk on trusses or gable ends lying flat**

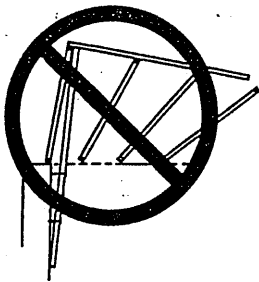

**Nails in withdrawal (parallel to force)**

All anchors, hangers, tie-downs, seats, bearing ledgers, etc., that are part of the supporting structure shall be accurately and properly placed and permanently attached before truss installation begins. No trusses shall ever be installed on anchors or ties that have temporary connections to the supporting structure.

Nailing scabs to the end of the building to brace the first truss is not recommended.

All nailing of bracing should be done so that nails are driven perpendicular to the direction of force, as shown at right.

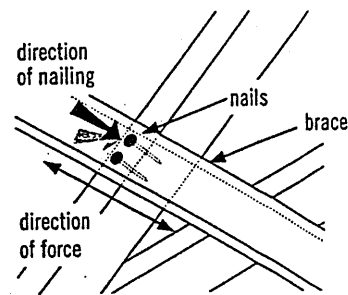

**Well nailed (perpendicular to force)**

# 7 Bracing Requirements for 3 Planes of Roof

Temporary erection bracing must be applied to three planes of the roof system to ensure stability: Plane 1) Top Chord (sheathing), Plane 2) Bottom Chord (ceiling plane), and Plane 3) Web Member plane or vertical plane perpendicular to trusses.

## 1) Top Chord Plane

Most important to the builder or erection contractor is bracing in the plane of the top chord. Truss top chords are susceptible to lateral buckling before they are braced or sheathed.

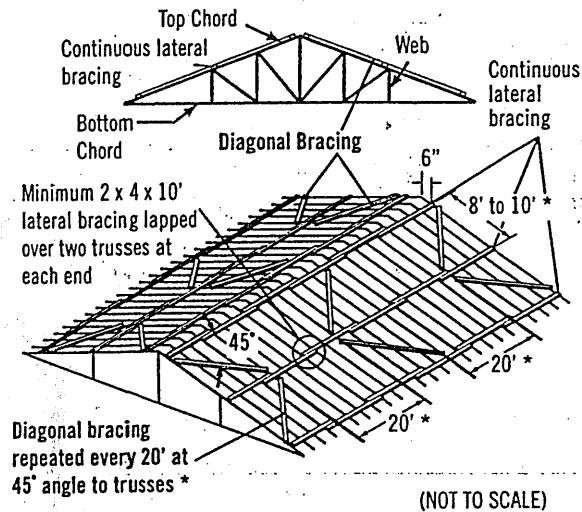

Exact spacing between trusses should be maintained as bracing is installed to avoid the hazardous practice of removing bracing to adjust spacing. This act of "adjusting spacing" can cause trusses to topple if connections are removed at the wrong time.

## 3) Web Member Plane

"X" bracing, as shown, is critical in preventing trusses from leaning or dominoing. Repeat as shown to create a succession of rigid units.

X-bracing should be installed on vertical web members wherever possible, at or near lateral bracing. Plywood or OSB may be substituted for X-bracing.

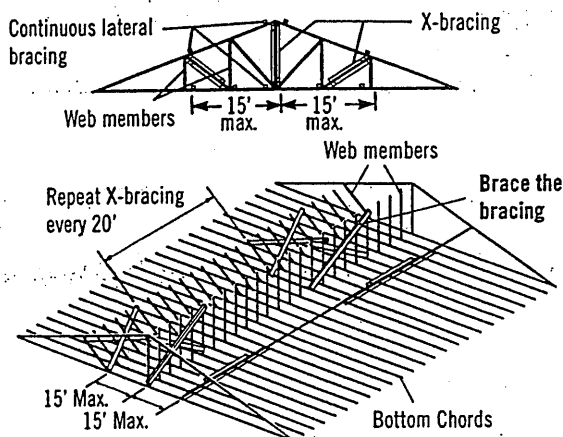

Note: Top chords and some web members are not shown, in order to make drawings more readable.

## 2) Bottom Chord Plane

In order to hold proper spacing on the bottom chord, temporary bracing is recommended on the top of the bottom chord.

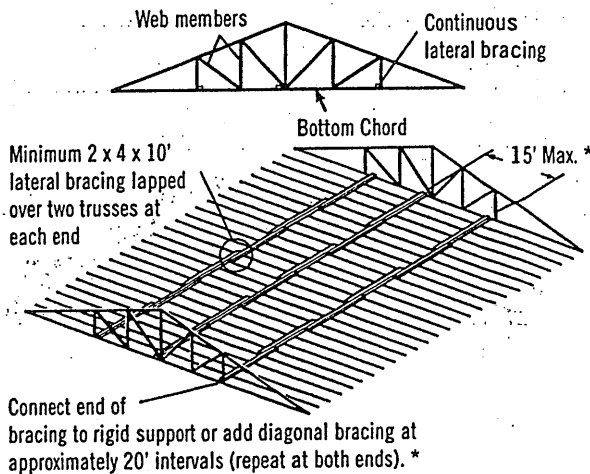

\* Long spans, heavy loads or other spacing configurations may require closer spacing between lateral bracing and closer intervals between diagonals. Consult the building designer or HIB and DSB (*Recommended Design Specification for Temporary Bracing of Metal-Plate Connected Wood Trusses*) for details.

**Diagonal or cross-bracing is very important!**

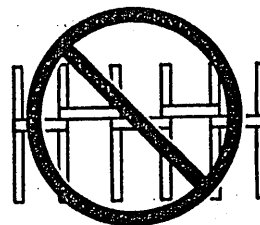

**Do not use short blocks to brace individual trusses without a specific bracing plan detailing their use**

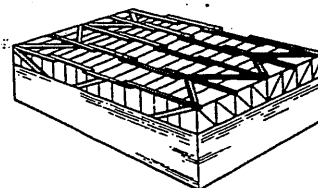

**Bracing requirements using the same principles apply to parallel chord trusses**

# 8 Stacking Materials

Do not proceed with building completion until all bracing is securely and properly in place

Never stack materials on unbraced or inadequately braced trusses

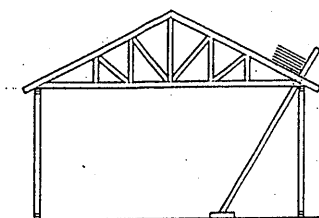
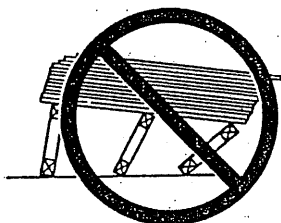

Platform must be rigidly braced

Proper distribution of construction materials is a must during construction.

Never stack materials near a peak

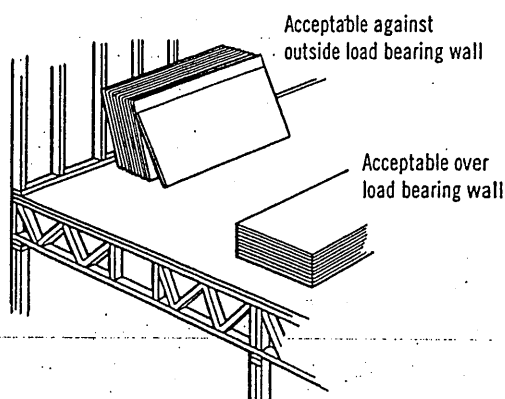
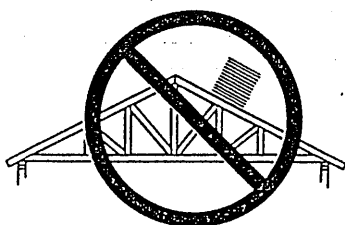

Acceptable against outside load bearing wall

Acceptable over load bearing wall

Never stack materials on the cantilever of a truss

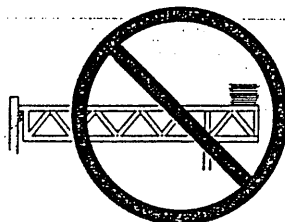

Always stack materials over two or more trusses.

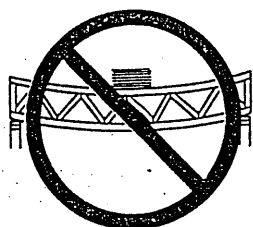
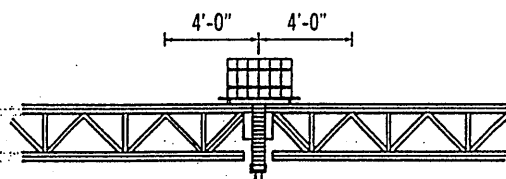

Single truss

Never overload small groups or single trusses. Position load over as many trusses as possible.

Roofing and mechanical contractors are cautioned to stack materials only along outside supporting members or directly over inside supporting members. Trusses are not designed for dynamic loads (i.e., moving vehicles). Extreme care should be taken when loading and stacking construction materials (rolled roofing, mechanical equipment, etc.) on the roof or floor system.

Never cut any structural member of a truss.

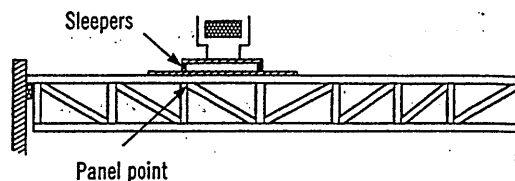
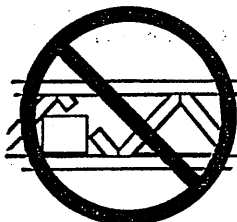

Sleepers

Panel point

Sleepers for mechanical equipment should be located at panel points (joints) or over main supporting members, and only on trusses that have been designed for such loads.

## Caution Notes

Errors in building lines and/or dimensions, or errors by others shall be corrected by the contractor or responsible construction trade subcontractor or supplier before erection of trusses begins.

Cutting of nonstructural overhangs is considered a part of normal erection and shall be done by the builder or erection contractor.

Any field modification that involves the cutting, drilling, or relocation of any structural truss member or connector plate shall not be done without the approval of the truss manufacturer or a licensed design professional.

The methods and procedures outlined are intended to ensure that the overall construction techniques employed will put floor and roof trusses safely in place in a completed structure. These recommendations for bracing wood trusses originate from the collective experience of leading technical personnel in the wood truss industry, but must, due to the nature of responsibilities involved, be presented only as a guide for use by a qualified building designer, builder, or erection contractor. Thus, the Wood Truss Council of America expressly disclaims any responsibility for damages arising from the use, application, or reliance on the recommendations and information contained herein.

[Selected text and figures referenced or reproduced from HIB and DSB by permission of the Truss Plate Institute, Madison, WI.]

THE CANADIAN WOOD TRUSS ASSOCIATION



L'ASSOCIATION CANADIENNE DES FABRICANTS DE FERMES DE BOIS

1400 Blair Place, Suite 210, Ottawa, ON K1J 9B8  
Tel.: 613-747-5544 Fax: 613-747-6264



**Wood Truss Council  
of America**

One WTCA Center  
6300 Enterprise Lane, Madison, WI 53719-1140  
Tel.: 608-274-4849 Fax: 608-274-3329  
[wtca@woodtruss.com](mailto:wtca@woodtruss.com) [www.woodtruss.com](http://www.woodtruss.com)